

Mini slide DGST

FESTO

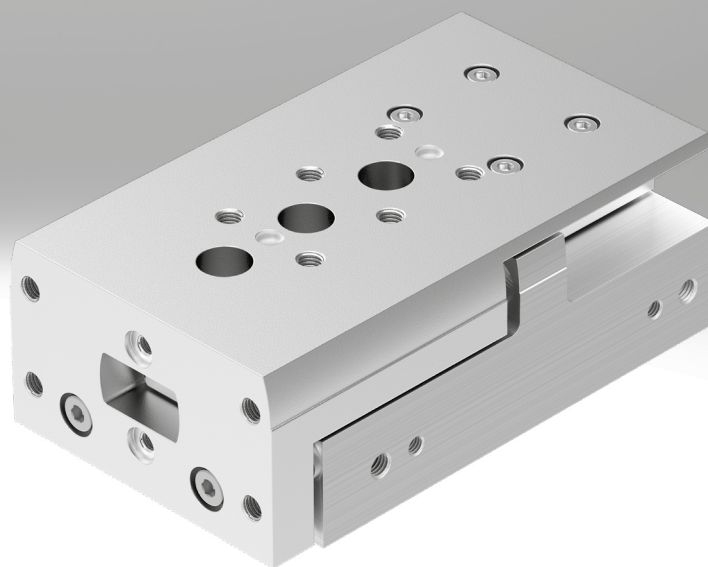

Key features

At a glance

- Compact mini slide
- Slide and yoke plate as a single component
- Excellent value for money
- High feed forces
- Symmetrical mounting interfaces
- Precise and resilient roller bearing guide
- Simple design with symmetrical mounting interfaces
- Can be operated without additional cushioning components

The technology in detail

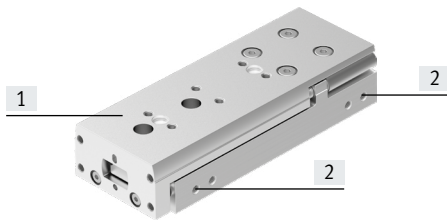

[1] Slide and yoke plate



- Slide and yoke plate as a single component, ensuring very high rigidity, precision and alignment



[2] Supply ports

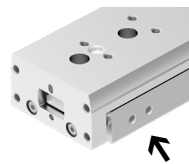

- All connections on one side

[3] Sensor slots for sensing the slide position

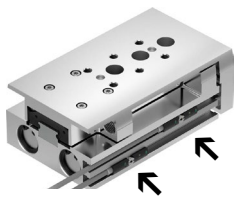

- Proximity switches can be integrated, so there are no projecting parts
- Both end positions can be sensed from one side
- Two sensor slots for sensing

[4] Cushioning and precision end-position adjustment

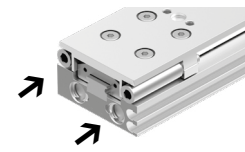

- Cushioning types:
 - Elastic cushioning rings/plates at both ends (P)
 - Elastomer cushioning, adjustable at both ends, with fixed stop (P1)
 - Elastomer cushioning, short, at both ends (E)
 - Elastomer cushioning, at both ends, stroke not adjustable (E1)
 - Shock absorber, self-adjusting, linear, at both ends, external (Y12)
- Precision end-position adjustment is possible from one end

[5] Twin-piston drive

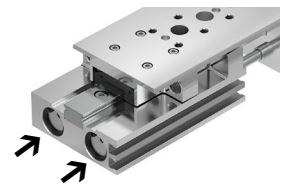

- Theoretical force at 6 bar: 34 ... 590 N
- Max. payload: 0.7 ... 17 kg

[6] Backlash-free piston rod/yoke connection

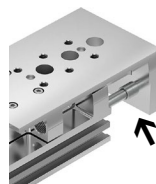

- Enhanced precision
- Longer service life

Version

[L] Mirror-imaged



- Position of the supply ports and sensor slots is mirror-inverted

Mounting example

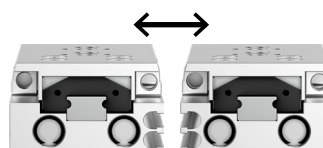

- Space-saving mounting of mini-slides next to one another

Key features

Axial supply ports via connection kit

→ Page 50

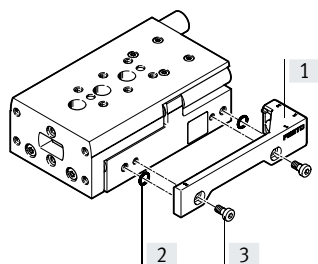

- The connection kit enables having axial supply ports
- Particularly suitable for applications in which no space is available at the side for supply ports

- [1] Connection set DADG-AK-G8-...
- [2] Seals
- [3] Screws

Intermediate-position module

→ Page 52

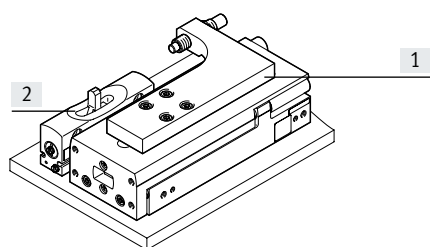

The intermediate-position module enables an additional adjustable position within the stroke range.

- The symmetrical design means that the intermediate position can be approached when advancing or retracting, depending on the assembly
- Can be travelled through from the end position
- Possible to continue on directly from the intermediate position
- Easy to assemble
- Sensing of the stop lever position is possible

- [1] Shock absorber retainer
- [2] Intermediate-position module

Application areas

Mainly in industry segments such as:

- Electronics and assembly technology
- Machine building
- Handling technology

Examples include the following:

- Pick & place handling units
- Piggyback handling units
- Precise positioning
- Precise press-fitting

Application examples

Pick & Place handling unit

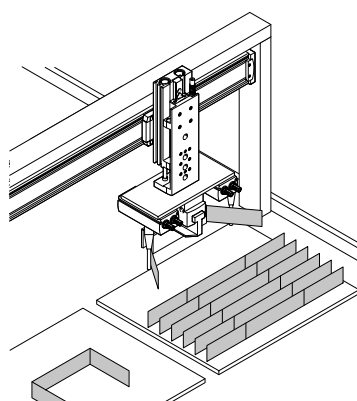
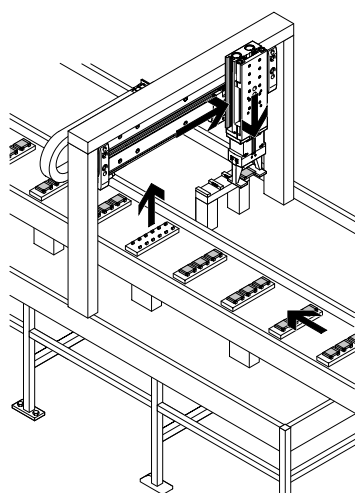

Peripherals overview

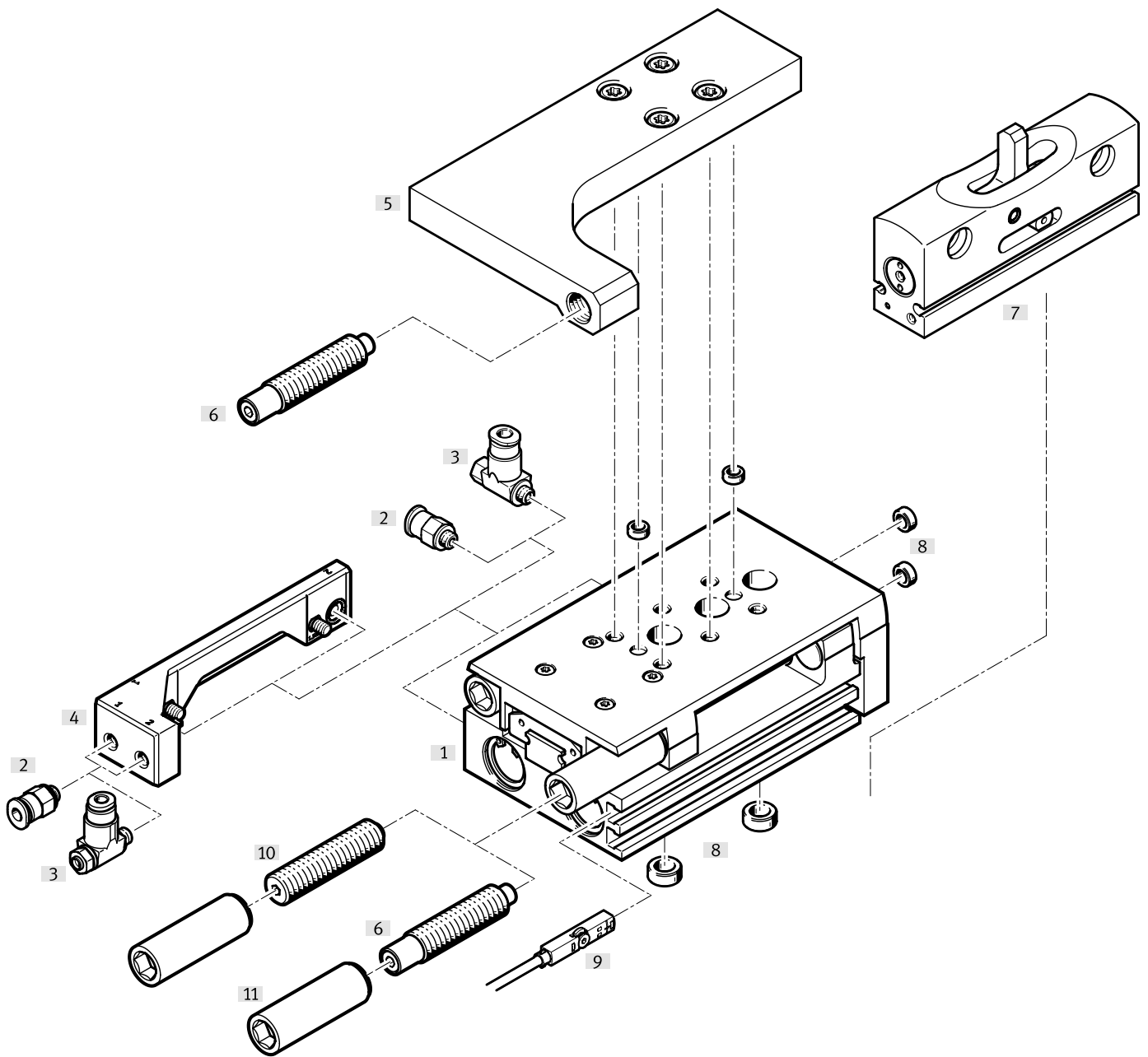

Peripherals overview

Accessories	Description	→ Page/Internet
[1] Mini slide DGST	Compact design	7
[2] Push-in fitting QSM	For connecting tubing with standard O.D.	56
[3] One-way flow control valve GRLA	For regulating speed	56
[4] Connection set DADG-AK-G8	For axial connection of compressed air tubing	50
[5] Shock absorber retainer DADP	<ul style="list-style-type: none"> • Attachment for the shock absorber • For positioning and cushioning the intermediate position 	54
[6] Cushioning Y12	Shock absorber, self-adjusting, linear, at both ends, external	55
[7] Intermediate-position module DADM	With stop lever for the intermediate position	52
[8] Centring sleeve ZBH	<ul style="list-style-type: none"> • For centring loads and attachments • (Centring sleeves not included in the scope of delivery of the mini slide) 	56
[9] Proximity switch SMT-10/-8	For position sensing Can be integrated in the sensor slot, so it does not protrude	57
Position transmitter SMAT-8M, SDAT	<ul style="list-style-type: none"> • Analogue position feedback possible • Choice of analogue output: 0 ... 10 V, 0 ... 20 mA 	58
[10] Cushioning P	Elastic cushioning rings/plates at both ends	55
Cushioning P1	Elastomer cushioning, adjustable at both ends, with fixed stop	55
Cushioning E	Elastomer cushioning, short, at both ends	55
– Distance sensor SOIA	For monitoring the condition of the damping elements	55
[11] Threaded sleeve	<ul style="list-style-type: none"> • For mounting the cushioning components • Included in the scope of delivery for cushioning [6]/[8] 	56

Type codes

001	Series
DGST	Slide drive

002	Size [mm]
6	6
8	8
10	10
12	12
16	16
20	20
25	25

003	Stroke [mm]
10	10
20	20
30	30
40	40
50	50
80	80
100	100
125	125
150	150
200	200

004	Version
	Standard
L	Mirror-inverted

005	Cushioning
P	Elastic cushioning rings/plates on both sides
P1	Elastomer cushioning, adjustable on both sides, with fixed stop
E	Elastomer cushioning, short, on both sides
E1	Elastomer cushioning, double-sided, stroke not adjustable
Y12	Shock absorber, self-adjusting, linear at both ends, external



006	Position sensing
A	For proximity sensor

007	Special material properties
	None
F1A	Recommended for production facilities for the manufacture of lithium-ion batteries

008	Lubrication
	Standard
H1	Food-safe lubrication

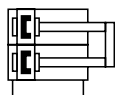
Datasheet



-  Size
6 ... 25
-  Stroke length
10 ... 200 mm



General technical data		6	8	10	12	16	20	25	
Size		6	8	10	12	16	20	25	
Design		Twin piston, piston rod, slide, yoke							
Guide		Recirculating ball bearing guide					Three-part cage guide		
Operating mode		Double-acting							
Type of mounting		Via through-hole With female thread							
Pneumatic connection		M3		M5		G1/8			
Stroke ¹⁾	[mm]	10 ... 50	10 ... 80	10 ... 100	10 ... 100	10 ... 150	10 ... 200	10 ... 200	
Cushioning									
DGST...P		Elastic cushioning rings/plates at both ends							
DGST...P1		Elastomer cushioning, adjustable at both ends, with fixed stop							
DGST...E		Elastomer cushioning, short, at both ends							
DGST...E1		Elastomer cushioning, at both ends, stroke not adjustable							
DGST...Y12		Shock absorber, self-adjusting, linear, at both ends, external							
Max. cushioning length									
DGST...P/-E	[mm]	0.9	1.5	1.5	1.3	1	1.2	1.2	
DGST...P1	[mm]	1.7	2.8	3.1	3.4	3.7	–	–	
DGST...E1 ²⁾	[mm]	0.25/0.9	0.5/1.5	0.6/1.6	0.5/1.1	0.6/0.8	0.5/1	0.5/1.2	
DGST...Y12	[mm]	4	4	4	5	5	8	10	
Position sensing		Via proximity switch							
Mounting position		Any							
Max. speed									
DGST...P/-E	[m/s]	0.5	0.8						
DGST...P1	[m/s]	0.45	0.5				–	–	
DGST...E1	[m/s]	0.5							
DGST...Y12	[m/s]	0.5	0.8						
Repetition accuracy									
DGST...P/-E/-E1	[mm]	≤ 0.3							
DGST...P1 ³⁾ /-Y12	[mm]	≤ 0.02							

1) For variant DGST...E1, the actual stroke is slightly longer → page 18

2) Advanced end position/retracted end position

3) Variant P1 only available for sizes 6 ... 16

Operating and environmental conditions		6	8	10	12	16	20	25
Operating medium		Compressed air to ISO 8573-1:2010 [7:4:4]						
Information on the operating medium		Lubricated operation possible (in which case lubricated operation will always be required)						
Operating pressure ¹⁾	[MPa]	0.15 ... 0.8		0.1 ... 0.8				
	[psi]	21.75 ... 116		14.5 ... 116				
	[bar]	1.5 ... 8		1 ... 8				
Ambient temperature	[°C]	–10 ... +60						
Corrosion resistance class CRC ²⁾		1 - Low corrosion stress						

1) For sizes 6/8/10/12, the min. operating pressure may increase slightly after an idle period > 24 h.

2) More information: www.festo.com/x/topic/crc

Datasheet

Forces and impact energy							
Size	6	8	10	12	16	20	25
Theoretical force at 6 bar, advancing [N]	34	60	94	136	241	377	589
Theoretical force at 6 bar, retracting [N]	25	45	79	102	207	317	495
Impact energy in the end positions							
DGST...-P/-E [J]	0.018	0.05	0.08	0.12	0.25	0.35	0.45
DGST...-P1 [J]	0.005	0.02	0.03	0.04	0.06	–	–
DGST...-E1 [J]	0.012	0.03	0.05	0.07	0.15	0.2	0.3
DGST...-Y12, per stroke [J]	0.1	0.4	0.8	1.4	2	3	6
Max. operating frequency							
DGST...-Y12 [Cycles/min]	50	80	80	80	70	50	50

For cushioning DGST...-P/-P1/-E/-E1, the following applies:

Permissible impact velocity:

$$v = \sqrt{\frac{2 \cdot E}{m_1 + m_2}}$$

Maximum permissible mass:

$$m_2 = \frac{2 \cdot E}{v^2} - m_1$$

v permissible impact speed

E Maximum impact energy

m₁ Moving mass (drive)

m₂ Moving payload

 **Note**

These specifications represent the maximum values that can be achieved. The maximum permissible impact energy must be observed.

For cushioning DGST...-Y12, the following applies:

Permissible impact velocity:

$$v = \sqrt{\frac{2 \cdot (E - (F + (m_1 + m_2) \cdot g \cdot \sin(\alpha)) \cdot s)}{m_1 + m_2}}$$

Maximum permissible mass:

$$m_2 = \frac{E - F \cdot s}{\frac{1}{2} \cdot v^2 + g \cdot s \cdot \sin(\alpha)} - m_1$$

v Permissible impact speed

E Kinetic impact energy

F Cylinder force minus friction force

m₁ Moving mass (drive)

m₂ Moving payload

g Gravitational acceleration

s Shock absorber stroke

a Impact angle

v Impact velocity

 **Note**

These specifications represent the maximum values that can be achieved. The maximum permissible impact energy must be observed.

Datasheet

Weight [g] Size	Stroke [mm]	6	8	10	12	16	20	25
Product weight without cushioning component								
	10	90	129	247	391	454	978	1463
	20	107	154	254	456	482	986	1528
	30	124	176	292	501	510	994	1547
	40	140	200	324	563	629	1055	1743
	50	172	236	359	611	690	1196	1816
	80	–	310	496	776	930	1618	2452
	100	–	–	561	988	1060	1962	2868
	125	–	–	–	–	1294	2346	3507
	150	–	–	–	–	1402	2686	3927
	200	–	–	–	–	–	3275	4803
Moving mass without cushioning component								
	10	49	69	124	195	235	440	714
	20	57	80	134	238	256	448	738
	30	65	92	146	242	277	455	762
	40	73	103	165	284	324	498	877
	50	88	122	177	290	342	549	897
	80	–	155	240	360	462	759	1217
	100	–	–	269	465	515	890	1388
	125	–	–	–	–	637	1068	1703
	150	–	–	–	–	660	1221	1877
	200	–	–	–	–	–	1460	2282
Cushioning elements (1 cushion and 1 threaded sleeve)¹⁾								
DGST...-P		5	8.4	11.7	23	41	72.5	136.5
DGST...-P1		4.5	7.6	10.8	20.9	37.6	–	–
DGST...-E		3.5	4.8	6.9	14.6	26	41	67
DGST...-Y12		3.9	7.8	10.2	16	33	57	105

1) Add 1x for moving mass and 2x for total mass.

Materials

Sectional view

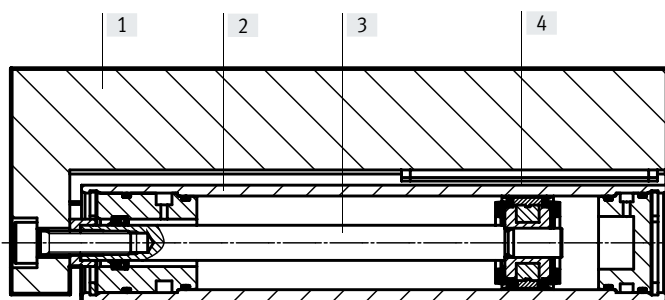

Mini slide	
[1] Slide	Wrought aluminium alloy
[2] Housing	Wrought aluminium alloy
[3] Piston rod	High-alloy stainless steel
[4] Guide	POM TPE-E High-alloy steel
– Cover	Wrought aluminium alloy
– Seals	HNBR
– Note on materials	RoHS-compliant
– LABS (PWIS) conformity	VDMA24364-B1/B2-L
– Cleanroom class	Class 6 to ISO 14644-1
– Suitable for the production of Li-ion batteries	Metals with more than 1% by mass of copper, zinc or nickel are excluded from use. Exceptions are nickel in steel, chemically nickel-plated surfaces, printed circuit boards, cables, electrical plug connectors and coils

Datasheet

Perpendicularity

The term perpendicularity refers to the alignment accuracy between the slide surface and the yoke plate.

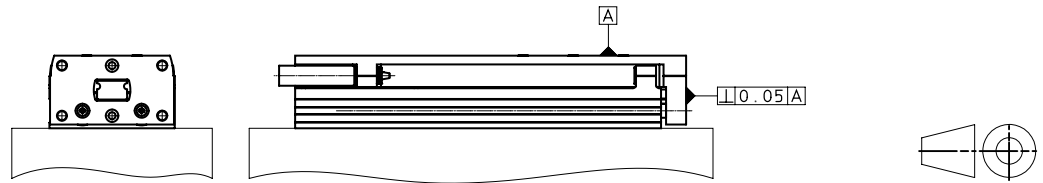

Size	6	8	10	12	16	20	25
	≤ 0.05						

Parallelism

The term parallelism refers to the alignment accuracy between the mounting surface and the slide surface in longitudinal direction.

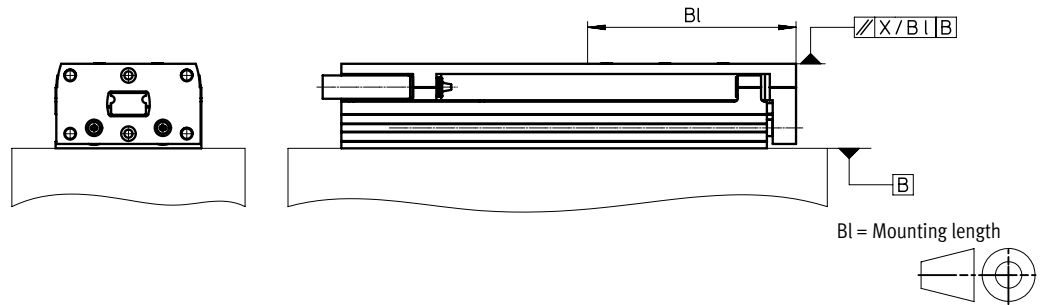

Size Stroke [mm]	6	8	10	12	16	20	25
10	0.092/43 ¹⁾	0.09/45	0.093/54	0.086/55	0.089/61	0.081/80	0.088/90
20	0.082/43	0.081/45	0.09/54	0.08/55	0.085/61	0.081/80	0.088/90
30	0.079/43	0.078/45	0.084/54	0.076/55	0.081/61	0.081/80	0.082/90
40	0.114/65	0.118/70	0.085/54	0.075/55	0.083/61	0.075/80	0.076/90
50	0.096/65	0.103/70	0.113/76	0.101/77	0.109/85	0.065/80	0.07/90
80	–	0.095/70	0.091/76	0.095/77	0.084/85	0.074/130	0.074/130
100	–	–	0.091/76	0.072/77	0.098/101	0.062/130	0.061/130
125	–	–	–	–	0.081/101	0.063/160	0.063/160
150	–	–	–	–	0.079/101	0.055/160	0.055/160
200	–	–	–	–	–	0.044/160	0.044/160

1) Parallelism/mounting length

Linearity

The term linearity refers to the alignment accuracy between the mounting surface and the slide surface in relation to the stroke.

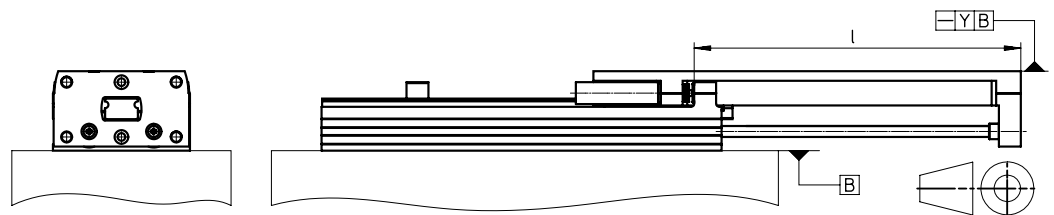

Size Stroke [mm]	6	8	10	12	16	20	25
10	0.013	0.012	0.011	0.011	0.01	0.009	0.009
20	0.021	0.02	0.018	0.016	0.016	0.014	0.014
30	0.025	0.024	0.023	0.021	0.021	0.02	0.018
40	0.029	0.028	0.026	0.025	0.025	0.022	0.021
50	0.031	0.029	0.029	0.027	0.026	0.024	0.023
80	–	0.034	0.032	0.032	0.03	0.02	0.027
100	–	–	0.035	0.032	0.032	0.027	0.027
125	–	–	–	–	0.033	0.028	0.028
150	–	–	–	–	0.035	0.03	0.03
200	–	–	–	–	–	0.032	0.032

Note: The values apply in an unpressurised state. When variants DGST with external cushioning are pressurised with compressed air, this may result in a pitching motion.

Datasheet

Adjustable end-position range

Precision adjustment of the advanced and retracted end positions

The required stroke reduction can be precisely adjusted with the cushioning components.

Advantages:

- No readjustment required; position is fully maintained under lock and load
- Stroke can be reduced to the next smaller standard stroke
- Fast and simple adjustment using two tools

Step 1:

Screw the cushioning component and sleeve into the holder using a hex wrench until the stop is reached

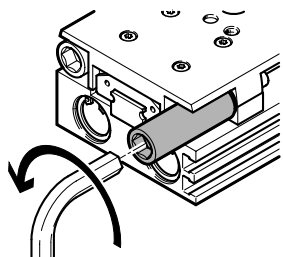

Step 2:

Set the exact end position using a smaller hex wrench

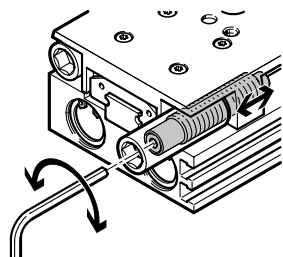

Step 3:

Secure the cushioning component by tightening the sleeve

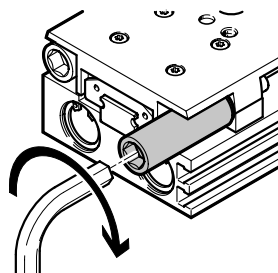

End-position adjustment

Dimensions:

For DGST-...-P: → page 38

For DGST-...-P1 → page 40

For DGST-...-E → page 42

For DGST-...-Y12: → page 44

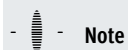

Note

Adjust and secure the shock absorber under pressure.

Datasheet

Dynamic load values

The indicated torques refer to the centre of the guide.
 These values must not be exceeded during dynamic operation. Special attention must be paid to the cushioning phase.

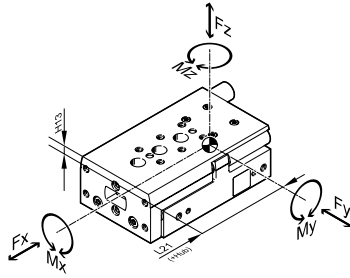

If the drive is simultaneously subjected to several of the forces and torques indicated below, the following equation must be satisfied in addition to the indicated maximum loads:

$$f_v = \frac{|F_{y1}|}{F_{y2}} + \frac{|F_{z1}|}{F_{z2}} + \frac{|M_{x1}|}{M_{x2}} + \frac{|M_{y1}|}{M_{y2}} + \frac{|M_{z1}|}{M_{z2}} \leq 1$$

f_v = load comparison factor

F_1 = dynamic value

F_2 = maximal value

Position of the guide centre

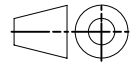
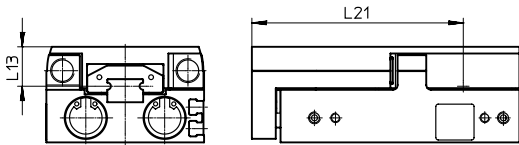

Calculation example

Assuming:

To be determined:

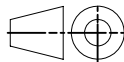
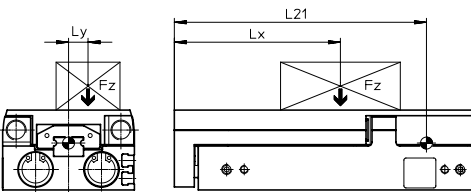

Mini slide = DGST-10-80
 Lever arm L_x = 0.05 m
 Lever arm L_y = 0.03 m
 Mass F_z = 0.8 kg
 Acceleration a = 0 m/s²

F_y, F_z, M_x, M_y, M_z
 and
 Functional operation with combined load

Solution:

Combined load:

$$f_v = \frac{|F_{y1}|}{F_{y2}} + \frac{|F_{z1}|}{F_{z2}} + \frac{|M_{x1}|}{M_{x2}} + \frac{|M_{y1}|}{M_{y2}} + \frac{|M_{z1}|}{M_{z2}} \leq 1$$

$$= 0 + \frac{7,848 \text{ N}}{520 \text{ N}} + \frac{0,236 \text{ Nm}}{6 \text{ Nm}} + \frac{0,47 \text{ Nm}}{5 \text{ Nm}} + 0 = 0,148 \leq 1$$

$L_{21} = 0.1102 \text{ m}$ from table

$F_y = 0 \text{ N}$

$F_z = m \times g$
 $= 0.8 \text{ kg} \times 9.81 \text{ m/s}^2 = 7.848 \text{ N}$

$M_x = m \times g \times L_y$
 $= 0.8 \text{ kg} \times 9.81 \text{ m/s}^2 \times 0.03 \text{ m} = 0.236 \text{ Nm}$

$M_y = m \times g \times (L_{21} - L_x)$
 $= 0.8 \text{ kg} \times 9.81 \text{ m/s}^2 \times (0.1102 \text{ m} - 0.05 \text{ m}) = 0.47 \text{ Nm}$

$M_z = 0 \text{ Nm}$

Permissible forces and torques

Geometric characteristics

Size	Stroke [mm]	$F_{y\max}, F_{z\max}$ [N]	$M_{x\max}$ [Nm]	$M_{y\max}, M_{z\max}$ [Nm]	L13 [mm]	L21 [mm]
6	10	200	1.1	0.7	9.35	31
	20	220	1.1	1		39.5
	30	240	1.1	1.2		51
	40	260	1.2	1.2		59.5
	50	280	1.4	1.2		73.5
8	10	250	2	2	10.75	31
	20	275	2	2		39.5
	30	300	2.8	2		51
	40	325	3	2.5		59.5
	50	350	3.2	3		73.5
	80	375	3.2	3		103.5

Datasheet

Permissible forces and torques					Geometric characteristics	
Size	Stroke [mm]	$F_{y_{max}}, F_{z_{max}}$ [N]	$M_{x_{max}}$ [Nm]	$M_{y_{max}}, M_{z_{max}}$ [Nm]	L13 [mm]	L21 [mm]
10						
	10	470	3	3	12.25	45.7
	20	480	3	3		45.7
	30	490	3.5	3		58.5
	40	500	4	4.5		65.7
	50	510	5	4.5		78.5
	80	520	6	5		110.2
	100	530	6	6		130.2
12						
	10	500	4.2	4.2	14.5	43
	20	520	4.2	4.2		53
	30	540	4.2	4.2		63
	40	560	5.8	5.8		73
	50	580	7	5.8		83
	80	600	8.9	6.5		113
	100	620	10	6.8		139
16						
	10	820	11.3	7	16.5	48.5
	20	840	11.3	7		55.5
	30	860	11.3	7.5		59.5
	40	880	11.3	8		71.5
	50	900	11.3	8		88.5
	80	920	12	10		119
	100	940	12	10		139
	125	960	14	15		171.5
	150	960	14	16		196.5
20						
	10	1600	16	18	16	70
	20	1270	13	14		70
	30	1110	11	12		71
	40	930	10	11		82
	50	1080	9	10		93.6
	80	1030	14	11		131.4
	100	1160	18	11		160.3
	125	1380	20	17		192.6
	150	1300	20	17		222.8
	200	1170	20	17		279.6
25						
	10	1840	19	21	21	69.2
	20	1460	16	16		69.2
	30	1280	14	14		78.2
	40	1310	13	12		88.2
	50	1080	12	11		98.2
	80	1030	14	11		133.4
	100	1160	18	11		162.8
	125	1380	20	17		194.6
	150	1300	20	17		224.8
	200	1170	20	17		281.6

Datasheet

Payload m as a function of impact velocity v and cushioning P/P1/E/E1

DGST-6

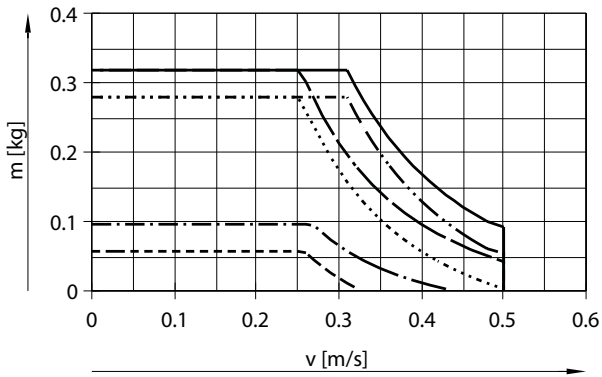

- DGST-6-10-E/-P
- DGST-6-50-E/-P
- - - DGST-6-10-E1
- · - · - DGST-6-50-E1
- - - - DGST-6-10-P1
- - - - DGST-6-50-P1

DGST-8

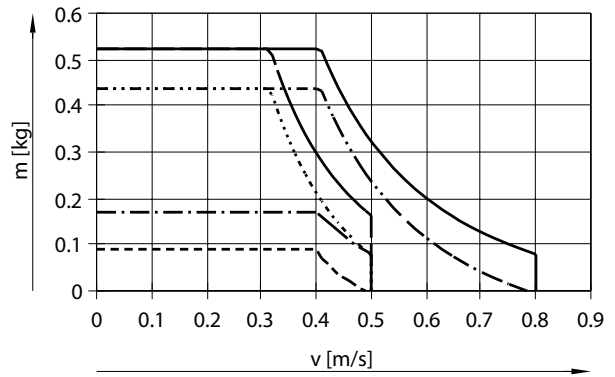

- DGST-8-10-E/-P
- DGST-8-80-E/-P
- - - DGST-8-10-E1
- · - · - DGST-8-80-E1
- - - - DGST-8-10-P1
- - - - DGST-8-80-P1

DGST-10

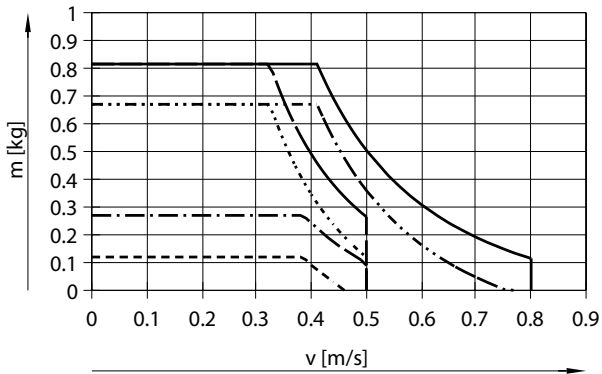

- DGST-10-10-E/-P
- DGST-10-100-E/-P
- - - DGST-10-10-E1
- · - · - DGST-10-100-E1
- - - - DGST-10-10-P1
- - - - DGST-10-100-P1

DGST-12

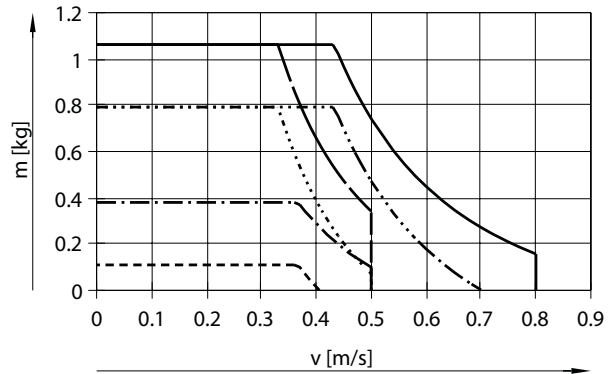

- DGST-12-10-E/-P
- DGST-12-100-E/-P
- - - DGST-12-10-E1
- · - · - DGST-12-100-E1
- - - - DGST-12-10-P1
- - - - DGST-12-100-P1

Datasheet

Payload m as a function of impact velocity v and cushioning P/P1/E/E1

DGST-16

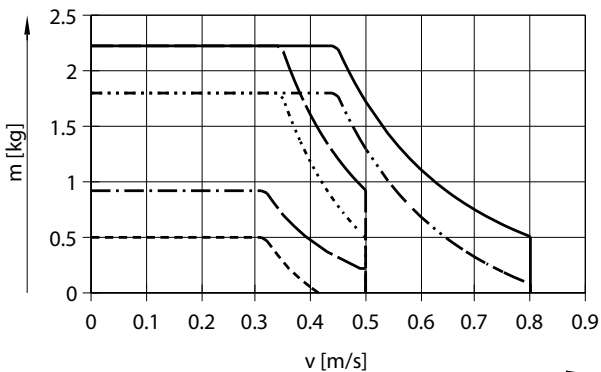

- DGST-16-10-E/-P
- DGST-16-150-E/-P
- - - DGST-16-10-E1
- · - · - DGST-16-150-E1
- - - - DGST-16-10-P1
- - - - DGST-16-150-P1

DGST-20

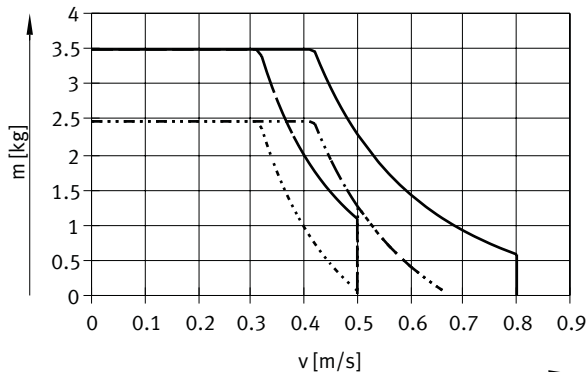

- DGST-20-10-E/-P
- DGST-20-200-E/-P
- - - DGST-20-10-E1
- · - · - DGST-20-200-E1

DGST-25

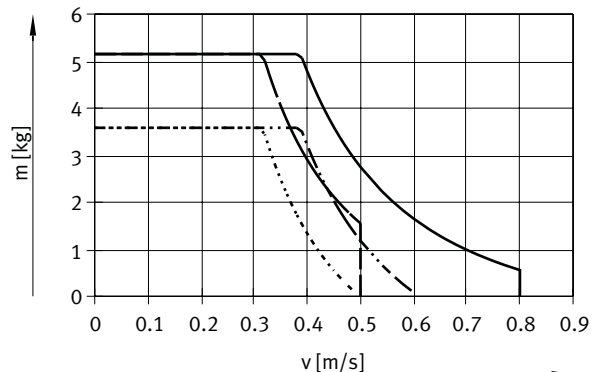

- DGST-25-10-E/-P
- DGST-25-200-E/-P
- - - DGST-25-10-E1
- · - · - DGST-25-200-E1

Datasheet

Payload m as a function of impact velocity v and cushioning Y12

DGST-6

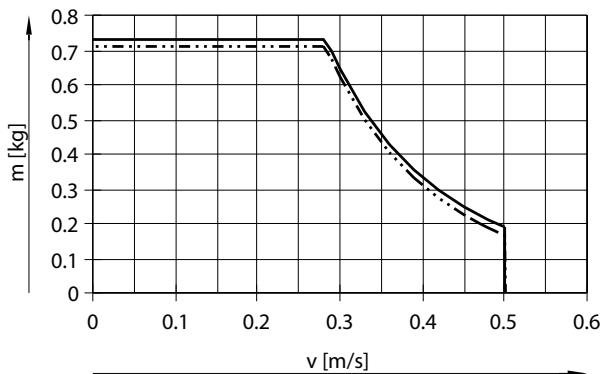

- DGST-6-30-Y12
- - - DGST-6-50-Y12

DGST-8

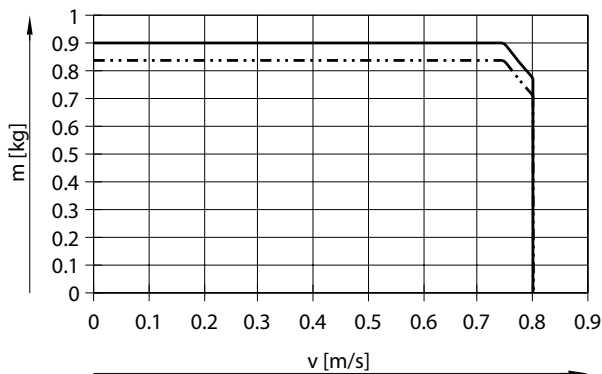

- DGST-8-30-Y12
- - - DGST-8-80-Y12

DGST-10

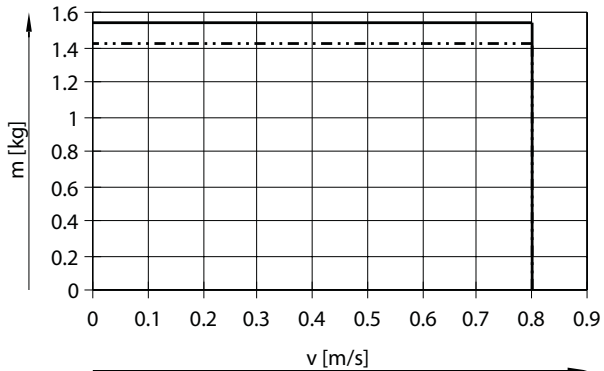

- DGST-10-30-Y12
- - - DGST-10-100-Y12

DGST-12

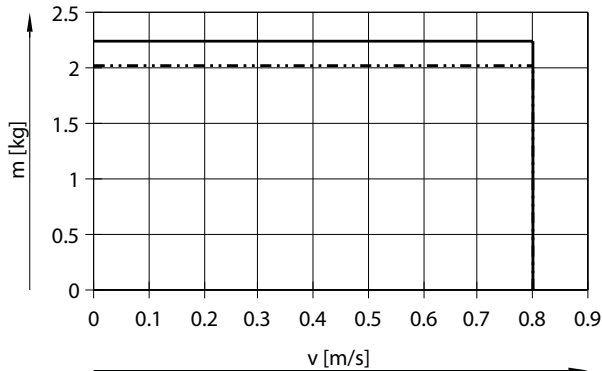

- DGST-12-30-Y12
- - - DGST-12-100-Y12

Datasheet

Payload m as a function of impact velocity v and cushioning Y12

DGST-16

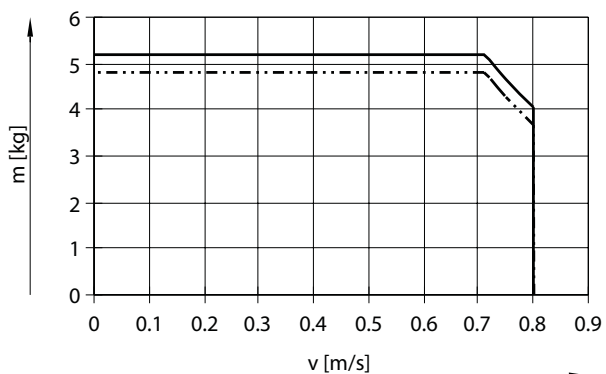

- DGST-16-30-Y12
- · - · - DGST-16-150-Y12

DGST-20

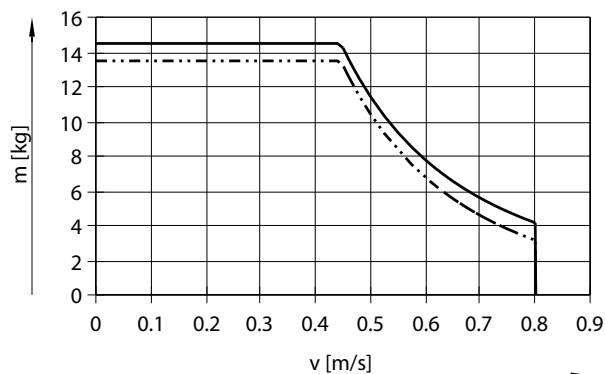

- DGST-20-30-Y12
- · - · - DGST-20-200-Y12

DGST-25

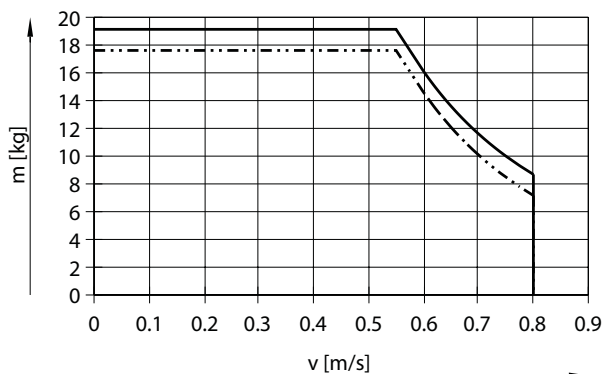

- DGST-25-30-Y12
- · - · - DGST-25-200-Y12

Datasheet

Dimensions

Download CAD data → www.festo.com

[] Standard

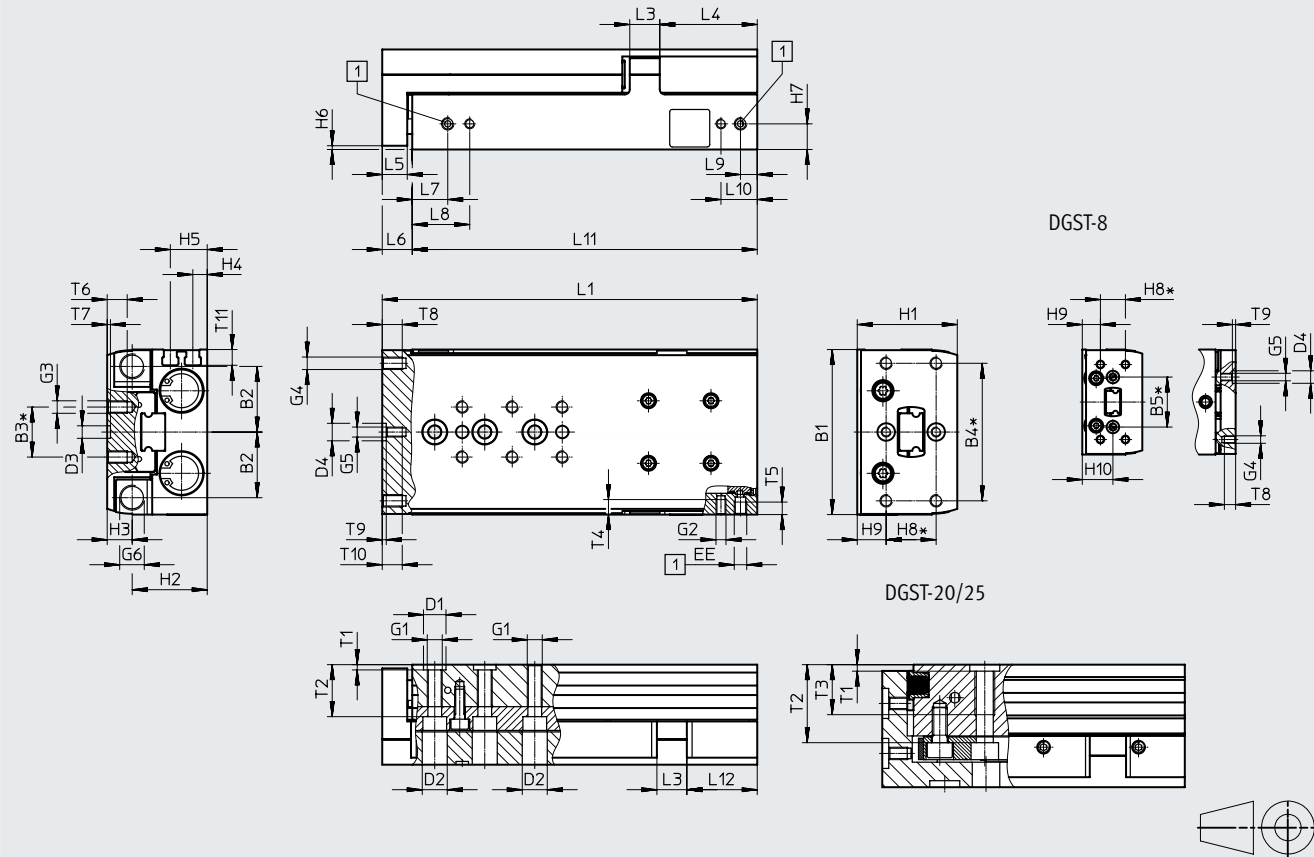

Actual stroke with variant DGST...-E1 =
stroke + additional stroke without cushioning + cushioning stroke
(values → page 19)

- [1] = Supply ports
- * = ±0.02 mm applies to the centring
- = ±0.1 mm applies to the thread

Size	B1	B2	B3	B4	B5	D1	D2	D3	D4	EE	G1	G2	G3	G4
			±0.1	±0.1		∅ H7	∅	∅ H7	∅					
6	35	14.4	10	30	–	5	6	5	2 ^{H8}	M3	M4	M3	M3	M3
8	42	17	10	30	20	5	6	5	5 ^{H7}	M5	M4	M3	M3	M3
10	50	20.8	20	40	–	7	8	5	5 ^{H7}	M5	M5	M4	M4	M4
12	60	24.5	20	40	–	7	8	5	7 ^{H7}	M5	M5	M4	M4	M4
16	66	26.3	20	55	–	9	10	5	7 ^{H7}	M5	M6	M4	M5	M5
20	85	34.5	40	70	–	12	11	12	12 ^{H7}	G1/8	M8	M5	M5	M5
25	104	42	40	80	–	12	11	12	12 ^{H7}	G1/8	M8	M6	M6	M6

Size	G5	G6	H1	H2	H3	H4	H5	H6	H7	H8	H9	H10	L3	L4
6	–	M4x0.5	20	14.5	5.5	2.5	7	1.5	4.5	10	5	–	5	22
8	M3	M5x0.5	24	17.7	6.3	3.1	8.1	1.5	5.6	10	7.3	12.3	6	30.5
10	M3	M6x0.5	29	21	8	4	10	1.5	7	20	5	–	8	31
12	M4	M8x1	36	26.5	9.5	5.9	11.9	1.5	8.9	20	9.5	–	10	36
16	M4	M10x1	40	30	10	5.8	14.8	1.5	10.3	20	11.6	–	12	39
20	M5	M12x1	49	36.5	12.5	8.7	17.7	2.5	13.2	20	15.5	–	14.5	51
25	M6	M14x1	60	44.5	15.5	11	21	2.5	16	40	10	–	17.5	65

Datasheet

Size	L5	L6 ¹⁾	L7	L8 ²⁾	L9	L10 ²⁾	T1	T2	T3 ³⁾ max.	T4 ³⁾ max.	T5 ³⁾ max.
6	6	8	8.5	15.4	5.8	12.7	1.3 ^{+0.1}	8.9	–	4	4
8	6	8	8.5	16.5	5.5	13.5	1.3 ^{+0.1}	11.5	–	5	4.5
10	8	10	8.9	17.9	6.6	15.6	1.6 ^{+0.1}	14.5	–	6.2	5
12	8	10	10.7	19.5	7	15.8	1.6 ^{+0.1}	19.8	–	7	5.5
16	10	12	14.2	23	6.7	15.5	2.1 ^{+0.1}	20.8	–	6	5
20	10	12.5	16.5	30.5	8	22	2.6 ^{+0.3}	31.2	20	8	8.5
25	12	14.5	16.5	31.5	10.5	25.5	2.6 ^{+0.3}	37.2	20	9.5	8

Size	T7	T8 ³⁾ max.	T9	T10 ³⁾ max.	T11	Additional stroke without cushioning with variant DGST...-E1		Max. cushioning stroke in the end positions with variant DGST...-E1	
						min.	max.	Advanced	Rear
6	1.3 ^{+0.1}	4.5	–	–	4.6	0.65	1.3	0.25	0.9
8	1.3 ^{+0.1}	4.5	1.3 ^{+0.1}	–	5	0	0.7	0.5	1.6
10	1.3 ^{+0.1}	6.5	1.3 ^{+0.1}	6.5	5.9	0	0.7	0.6	1.6
12	1.3 ^{+0.1}	6.5	1.6 ^{+0.1}	8	7	0.4	1.1	0.5	1.1
16	1.3 ^{+0.1}	8	1.6 ^{+0.1}	8	6.3	0.65	1.4	0.6	0.65
20	2.6 ^{+0.3}	8	2.6 ^{+0.3}	10	9.1	0.4	1.1	0.5	1
25	2.6 ^{+0.3}	10	2.6 ^{+0.3}	13	8.8	0.5	1.2	0.5	1.2

Stroke [mm]	10	20	30	40	50	80	100	125	150	200	
Size											
	L1¹⁾										
6	48	58	68	78	95	–	–	–	–	–	
8	51	61	71	81	95	126	–	–	–	–	
10	66	68	78	88	98	136	156	–	–	–	
12	66	76	86	96	106	136	169.5	–	–	–	
16	73	80	87	97	112	150	170	210	235	–	
20	97	97	97	107	121	166	204.5	244	279	343	
25	102	102	108	118	128	168	207	246	281	345	
	L11										
6	40	50	60	70	87	–	–	–	–	–	
8	43	53	63	73	87	118	–	–	–	–	
10	56	58	68	78	88	126	146	–	–	–	
12	56	66	76	86	96	126	159.5	–	–	–	
16	61	68	75	85	100	138	158	198	223	–	
20	84.5	84.5	84.5	94.5	108.5	153.5	192	231.5	266.5	330.5	
25	87.5	87.5	93.5	103.5	113.5	153.5	192.5	231.5	266.5	330.5	
	L12										
6	16	16	16	16	22	–	–	–	–	–	
8	15.7	15.7	15.7	15.7	19.7	20.7	–	–	–	–	
10	24.6	16.6	16.6	16.6	16.6	24.6	24.6	–	–	–	
12	20.6	20.6	20.6	20.6	20.6	20.6	34.1	–	–	–	
16	21.2	18.2	15.2	15.2	20.2	28.2	28.2	39	39	–	
20	39.5	29.5	19.5	19.5	23.5	38.5	51	51	51	51	
25	36.5	26.5	22.5	22.5	22.5	32.5	51.5	65	65	65	
	T6 (max.)³⁾										
6	4	4	4	4	4	–	–	–	–	–	
8	5.5	5.5	5.5	5.5	5.5	5.5	–	–	–	–	
10	4.5	4.5	4.5	4.5	4.5	7.5	7.5	–	–	–	
12	5.2	5.2	5.2	5.2	5.2	8	8	–	–	–	
16	7.2	7.2	7.2	7.2	7.2	8	8	8	8	–	
20	8	8	8	8	8	8	8	8	8	8	
25	11	11	11	11	11	11	11	11	11	11	

1) At an operating pressure of 6 bar for variant E1. For the other cushioning variants, LD1 applies → page 38 ff.

2) Not available in sizes 6 and 8 with stroke 10 mm. For size 16 with stroke 80 ... 150 mm, the dimension is 14.5 mm

3) Max. screw-in depth

Datasheet

Dimensions

Download CAD data → www.festo.com

[L] Mirror-imaged

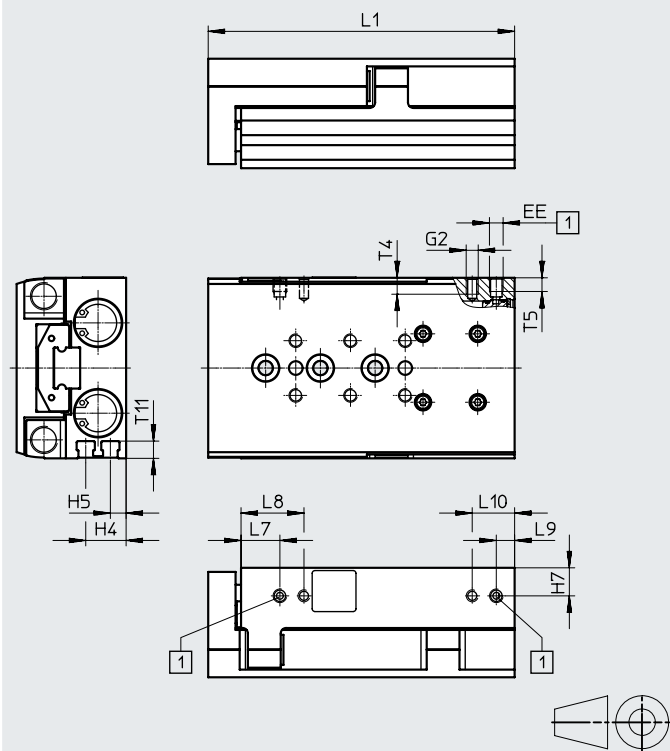

Note

In the mirror-inverted version, the supply ports and sensor slots are located on the opposite side when compared with the standard version. This enables the space-saving mounting of the mini-slides next to one another.

All further dimensions are identical to the standard version → page 18

+ = plus stroke length

[1] Supply ports

Datasheet

Size	EE	G2	H4	H5	H7	L7	L8 ²⁾	L9	L10 ²⁾	T4 ³⁾ max.	T5 ³⁾ max.	T11
6	M3	M3	2.5	7	4.5	8.5	15.4	5.8	12.7	4	4	4.6
8	M5	M3	3.1	8.1	5.6	8.5	16.5	5.5	13.5	5	4.5	5
10	M5	M4	4	10	7	8.9	17.9	6.6	15.6	6.2	5	5.9
12	M5	M4	5.9	11.9	8.9	10.7	19.5	7	15.8	7	5.5	7
16	M5	M4	5.8	14.8	10.3	14.2	23	6.7	15.5	6	5	6.3
20	G1/8	M5	8.7	17.7	13.2	16.5	30.5	8	22	8	8.5	9.1
25	G1/8	M6	11	21	16	16.5	31.5	10.5	25.5	9.5	8	8.8

Stroke [mm]	10	20	30	40	50	80	100	125	150	200	
Size	L1¹⁾										
6	48	58	68	78	95	–	–	–	–	–	
8	51	61	71	81	95	126	–	–	–	–	
10	66	68	78	88	98	136	156	–	–	–	
12	66	76	86	96	106	136	169.5	–	–	–	
16	73	80	87	97	112	150	170	210	235	–	
20	97	97	97	107	121	166	204.5	244	279	343	
25	102	102	108	118	128	168	207	246	281	345	

1) At an operating pressure of 6 bar

2) Not available in sizes 6 and 8 with stroke 10 mm. For size 16 with stroke 80 ... 150 mm, the dimension is 14.5 mm

3) Max. screw-in depth

Datasheet

Hole pattern for mounting threads and centring holes

Download CAD data → www.festo.com

DGST-6-10

DGST-6-20

DGST-6-30

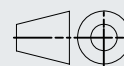
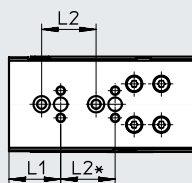
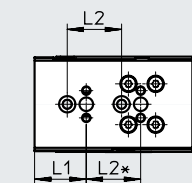
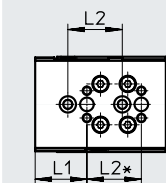
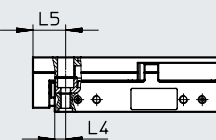
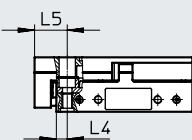
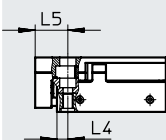
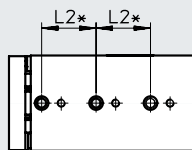
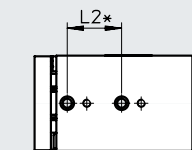
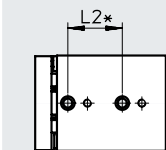

DGST-6-40

DGST-6-50

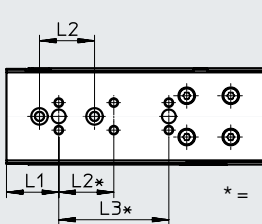
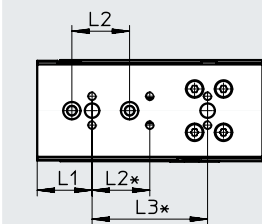
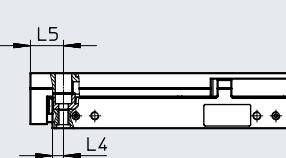
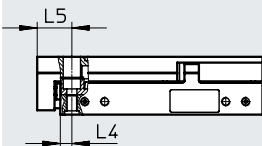
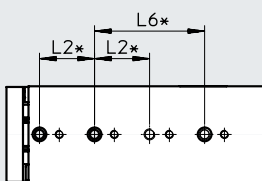
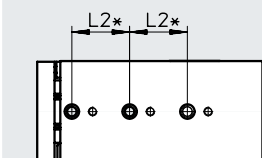

* = ±0.02 mm applies to the centring
 = ±0.1 mm applies to the thread



Size	Stroke [mm]	L1	L2	L3	L4	L5	L6
6	10	19	20	-	4	12	-
	20			-			-
	30			-			-
	40			40			-
	50			40			40

Datasheet

Hole pattern for mounting threads and centring holes

Download CAD data → www.festo.com

DGST-8-10

DGST-8-20

DGST-8-30

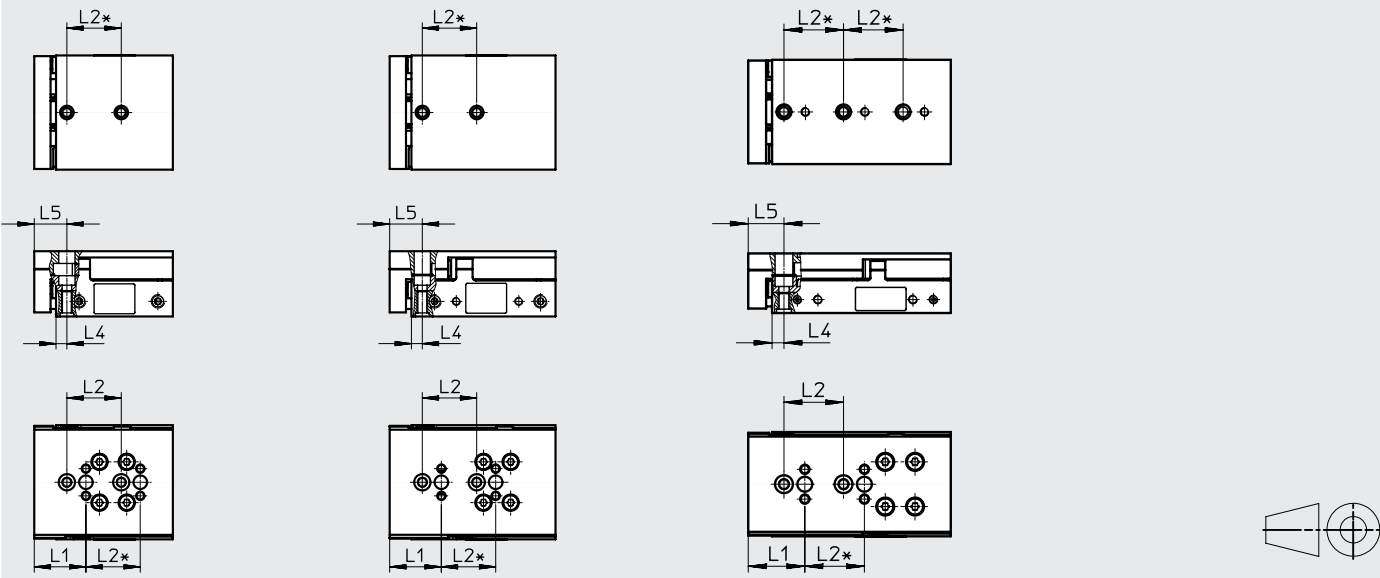

DGST-8-40

DGST-8-50

DGST-8-80

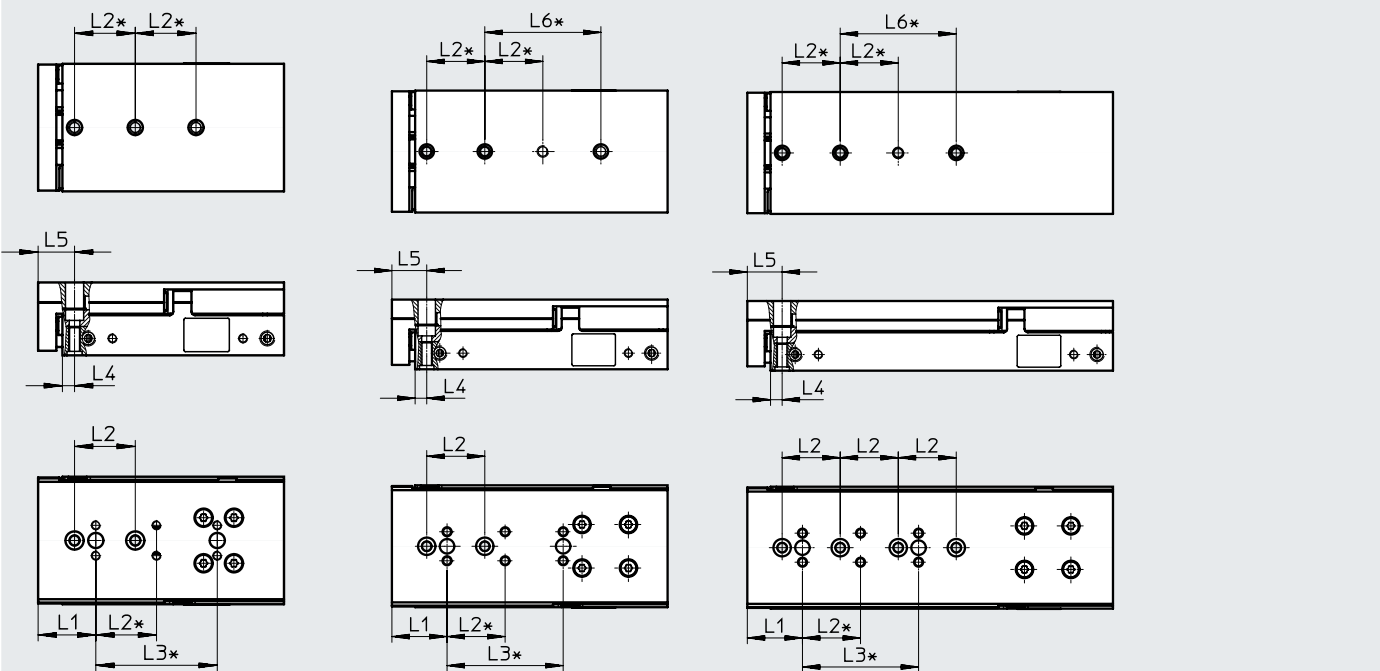

* = ±0.02 mm applies to the centring
 = ±0.1 mm applies to the thread

Size	Stroke [mm]	L1	L2	L3	L4	L5	L6
8	10	19	20	-	4	12	-
	20			-			
	30			-			
	40			40			
	50			40			
	80			40			

Datasheet

Hole pattern for mounting threads and centring holes

Download CAD data → www.festo.com

DGST-10-10/20

DGST-10-30

DGST-10-40

DGST-10-50

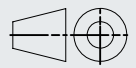
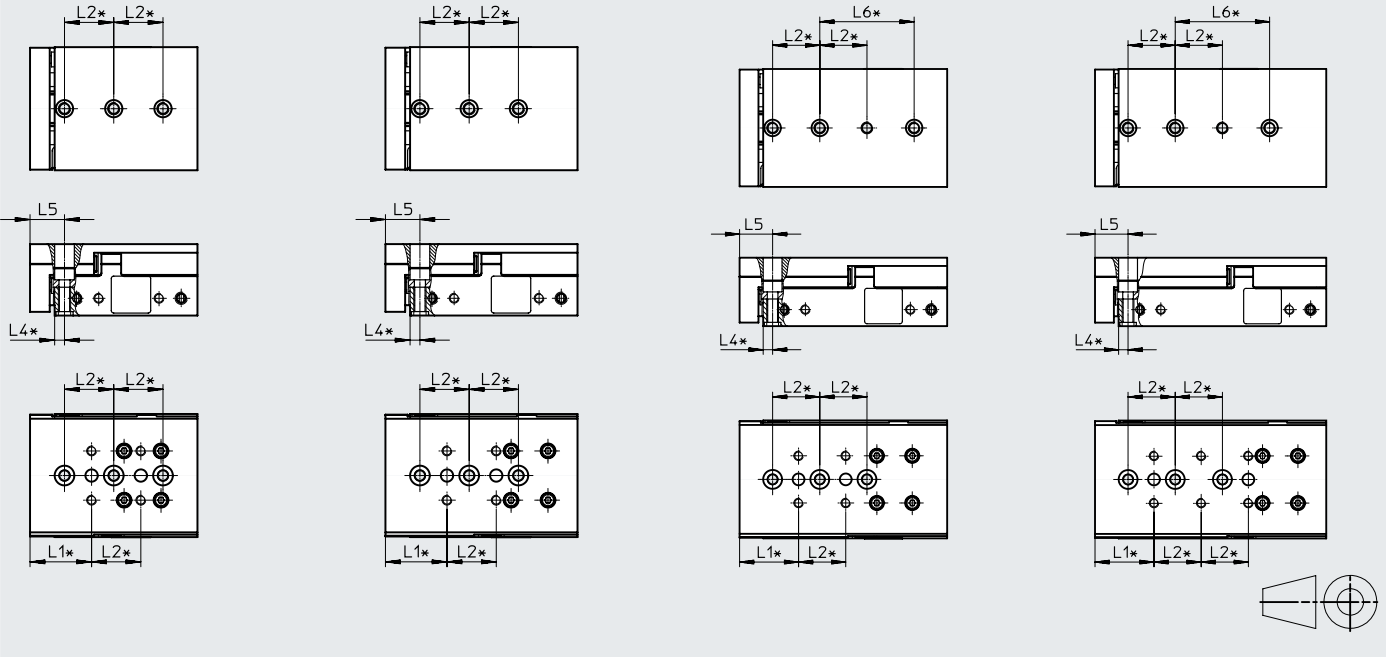

DGST-10-80

DGST-10-100

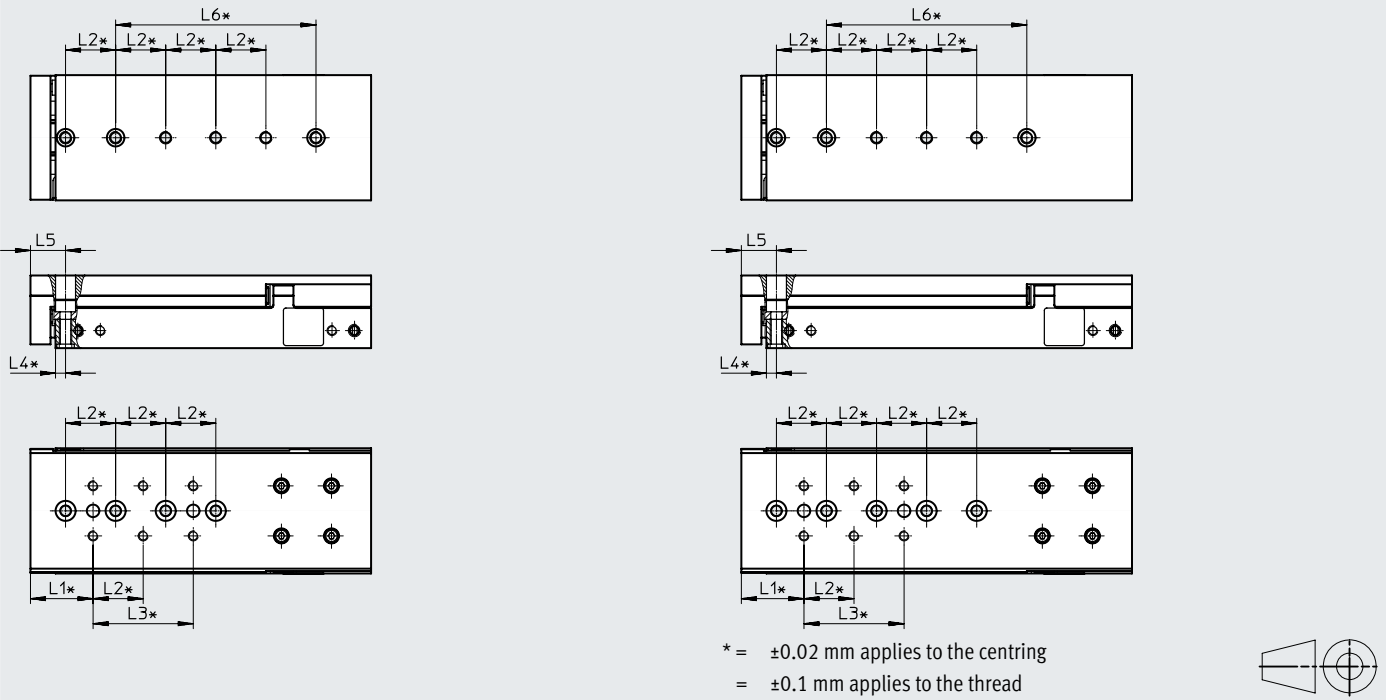

* = ±0.02 mm applies to the centring
 = ±0.1 mm applies to the thread

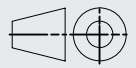

Size	Stroke [mm]	L1	L2	L3	L4	L5	L6
10	10, 20	25	20	-	4	14	-
	30			-			-
	40, 50			-			40
	80			40			80
	100			40			80

Datasheet

Hole pattern for mounting threads and centring holes

Download CAD data → www.festo.com

DGST-12-10

DGST-12-20

DGST-12-30

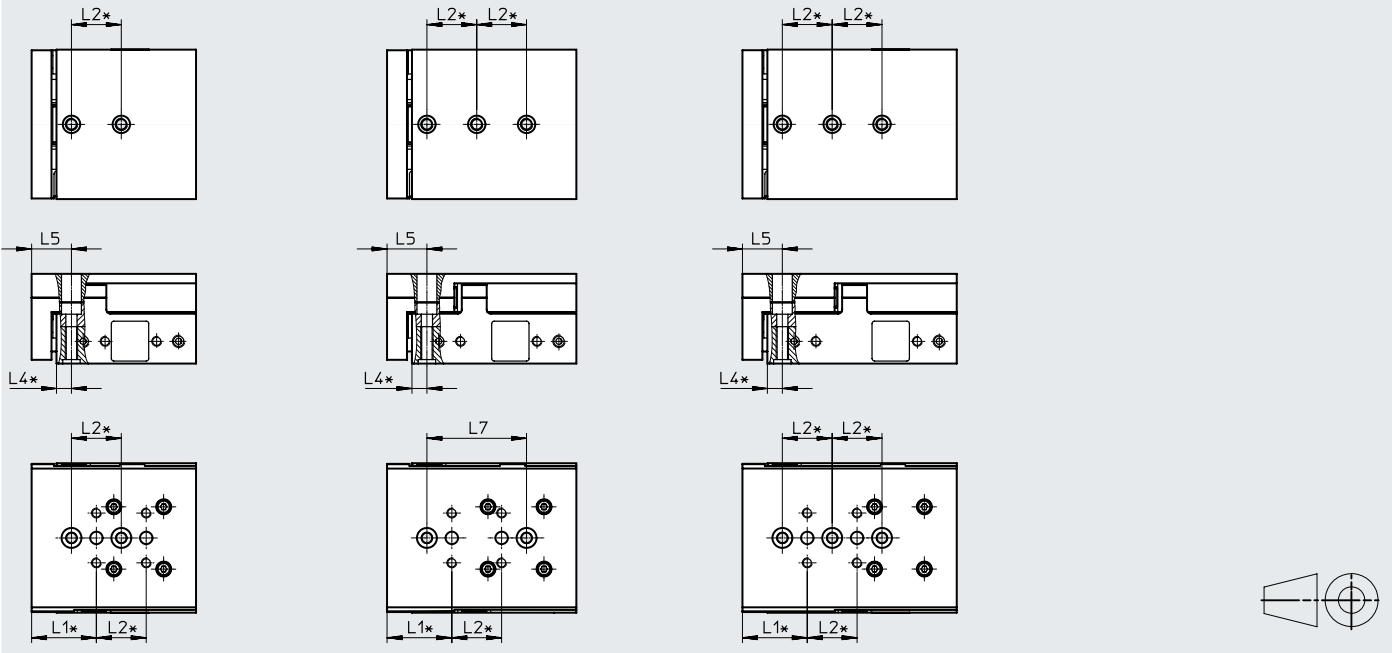

DGST-12-40

DGST-12-50/80

DGST-12-100

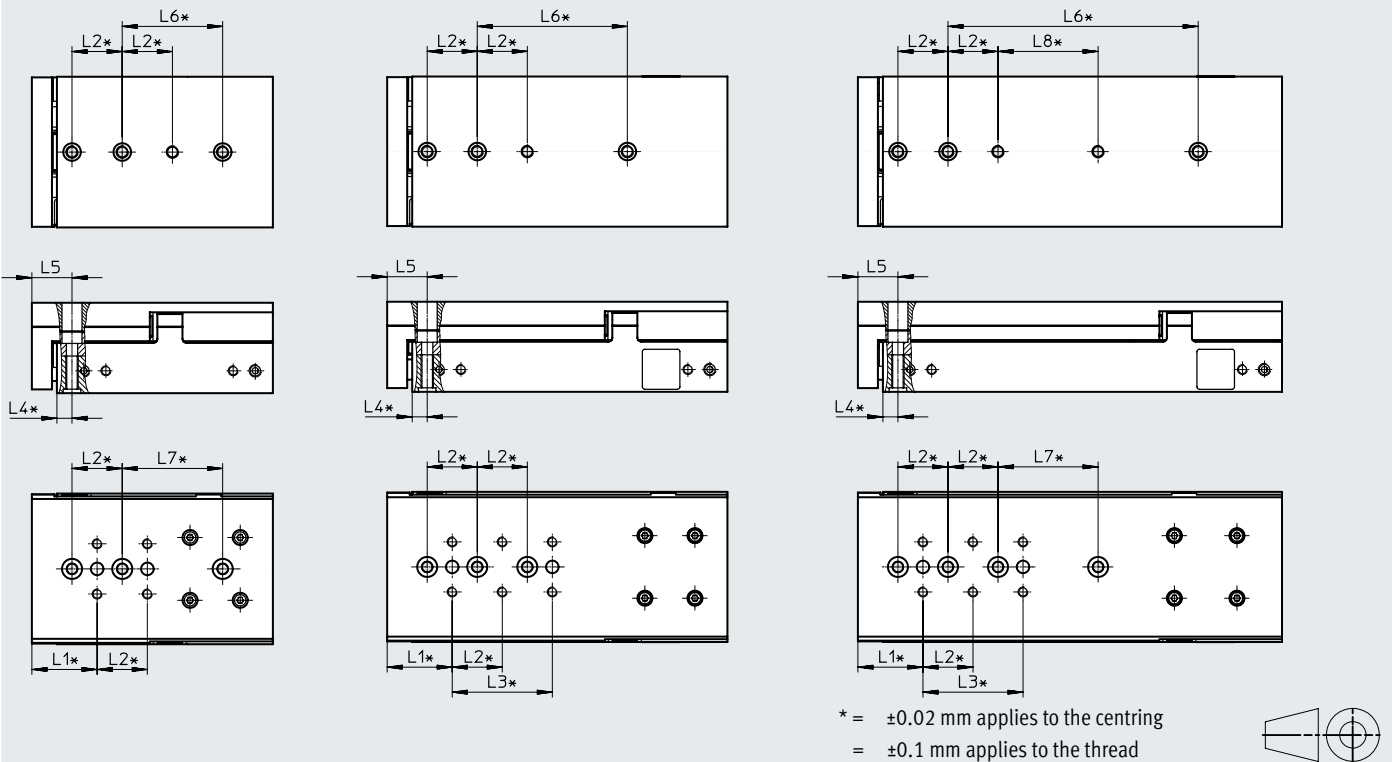

* = ±0.02 mm applies to the centring
 = ±0.1 mm applies to the thread

Size	Stroke [mm]	L1	L2	L3	L4	L5	L6	L7	L8		
12	10	26	20	–	6	16	–	–	–		
	20			–			–	40	–		
	30			–			–	–	–		
	40			–			–	40	40	–	
	50, 80			40			–	–	40, 60	–	–
	100			40			–	–	100	40	40

Datasheet

Hole pattern for mounting threads and centring holes

Download CAD data → www.festo.com

DGST-16-10

DGST-16-20/30

DGST-16-40

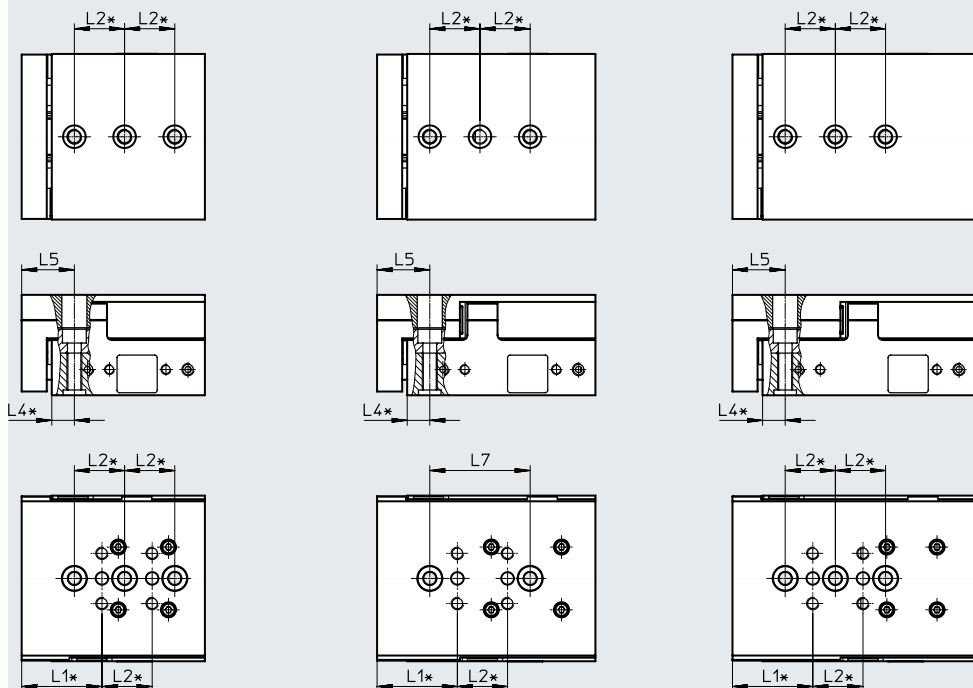

* = ±0.02 mm applies to the centring
 = ±0.1 mm applies to the thread



Size	Stroke [mm]	L1	L2	L4	L5	L7
16	10	32	20	9	21	-
	20					40
	30					40
	40					-

Datasheet

Hole pattern for mounting threads and centring holes

Download CAD data → www.festo.com

DGST-16-50

DGST-16-80

DGST-16-100

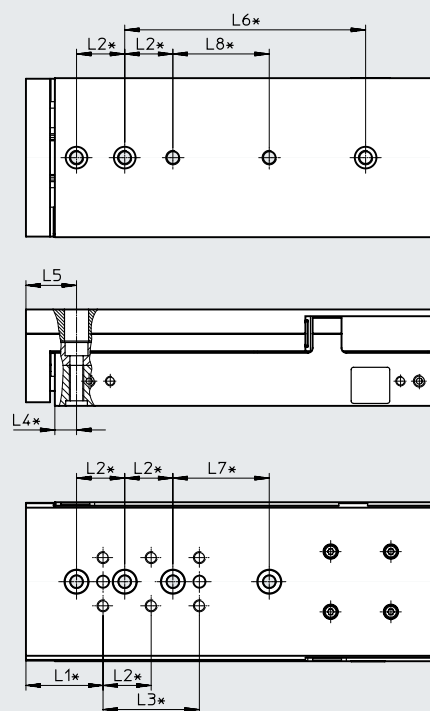
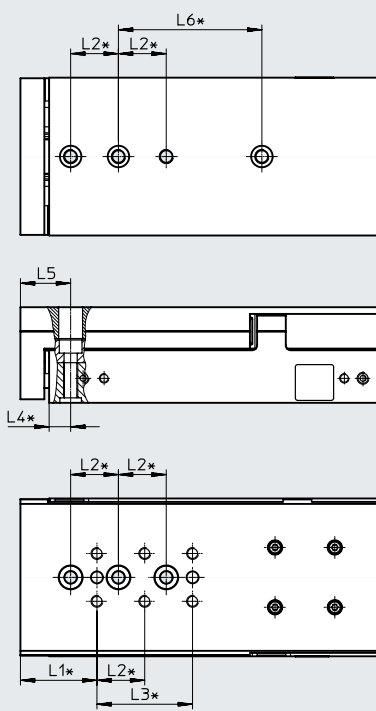
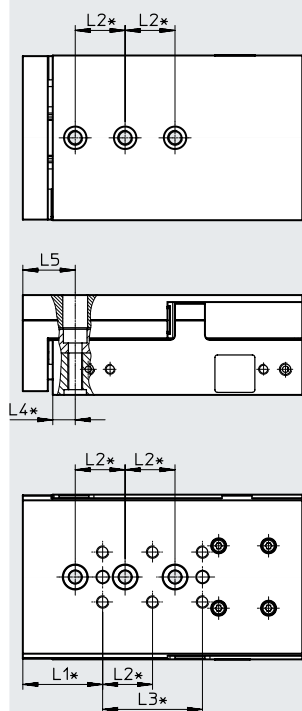

* = ±0.02 mm applies to the centring
 = ±0.1 mm applies to the thread



Size	Stroke [mm]	L1	L2	L3	L4	L5	L6	L7	L8
16	50	32	20	40	9	21	-	-	-
	80						60	-	-
	100						100	40	40

Datasheet

Hole pattern for mounting threads and centring holes

Download CAD data → www.festo.com

DGST-16-125

DGST-16-150

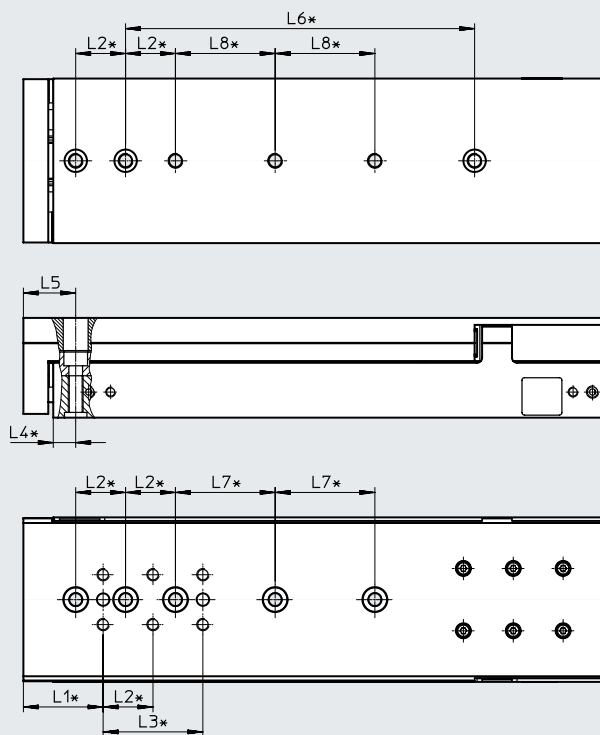
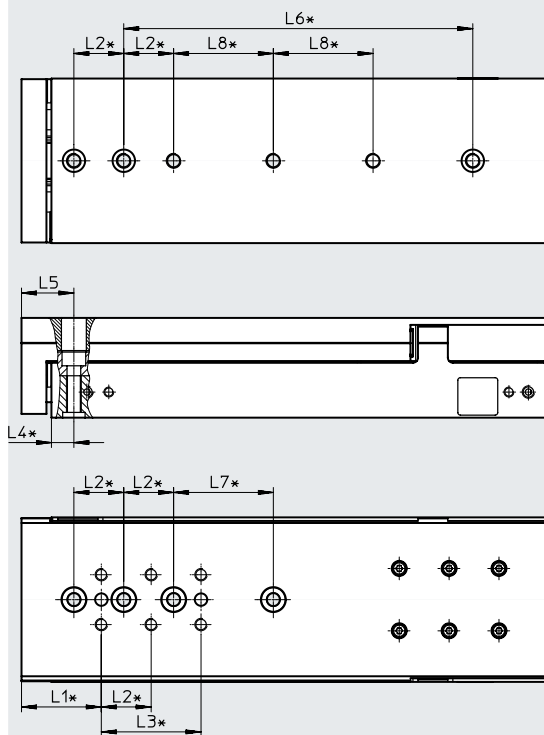

* = ±0.02 mm applies to the centring
 = ±0.1 mm applies to the thread

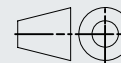

Size	Stroke [mm]	L1	L2	L3	L4	L5	L6	L7	L8
16	125	32	20	40	9	21	140	40	40
	150								

Datasheet

Hole pattern for mounting threads and centring holes

Download CAD data → www.festo.com

DGST-20-10/20/30/40

DGST-20-50

DGST-20-80

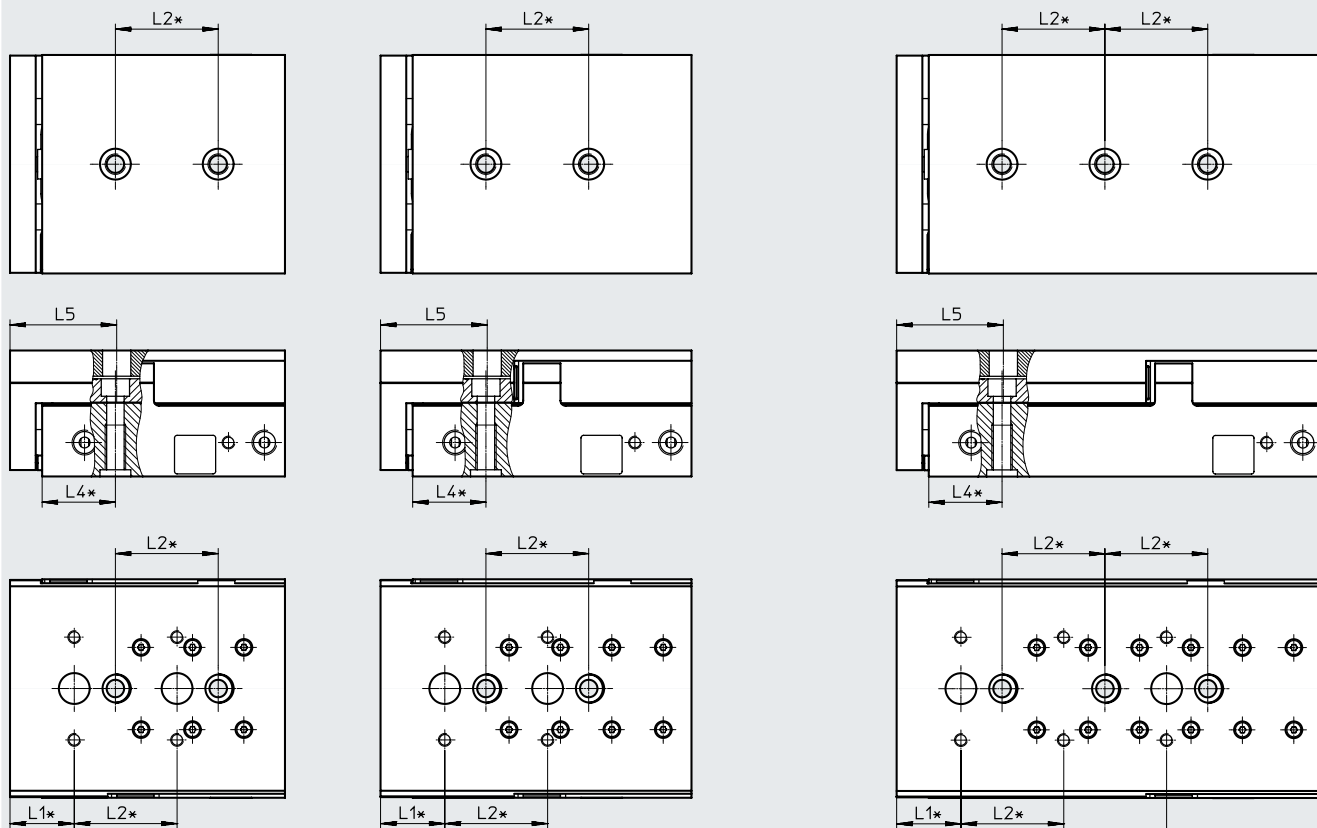

* = ±0.02 mm applies to the centring
 = ±0.1 mm applies to the thread



Size	Stroke [mm]	L1	L2	L3	L4	L5
20	10	25	40	-	28.5	41.5
	20			-		
	30			-		
	40			-		
	50			-		
	80			80		

Datasheet

Hole pattern for mounting threads and centring holes

Download CAD data → www.festo.com

DGST-20-100

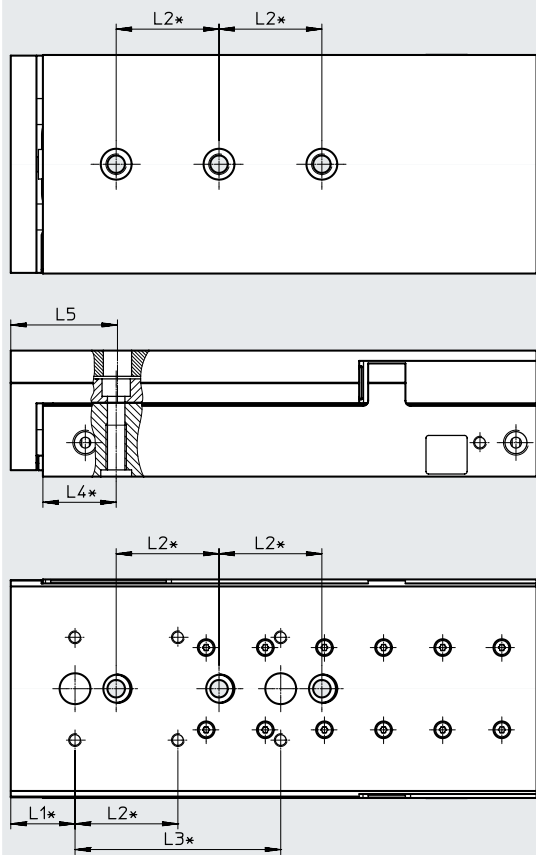

DGST-20-125

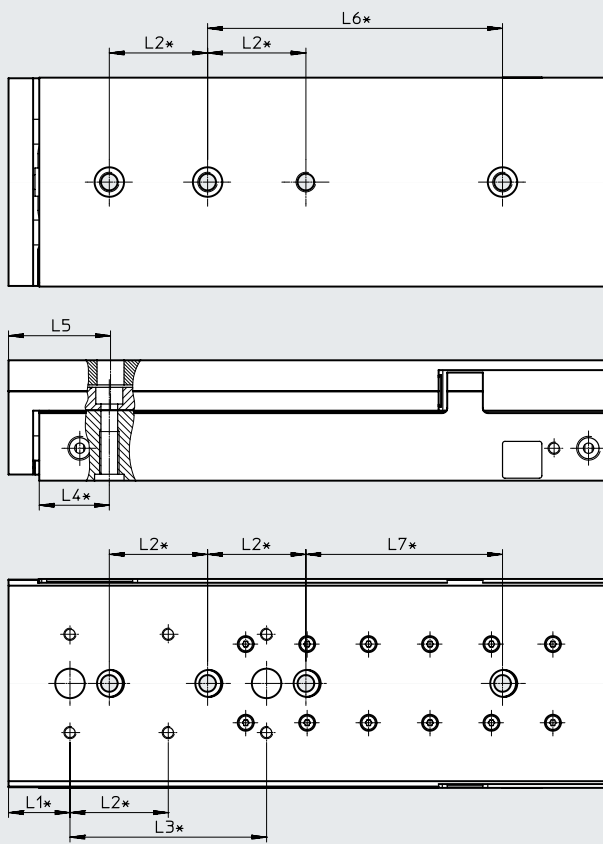

* = ±0.02 mm applies to the centring
 = ±0.1 mm applies to the thread



Size	Stroke [mm]	L1	L2	L3	L4	L5	L6	L7
20	100	25	40	80	28.5	41.5	-	80
	125						120	

Datasheet

Hole pattern for mounting threads and centring holes

Download CAD data → www.festo.com

DGST-20-150

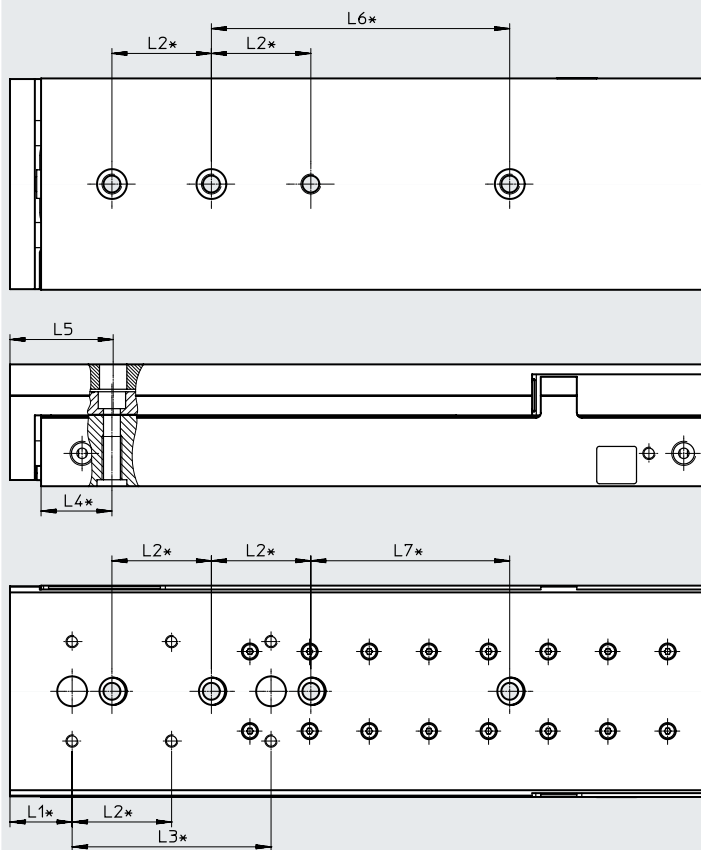

* = ±0.02 mm applies to the centring
 = ±0.1 mm applies to the thread



Size	Stroke [mm]	L1	L2	L3	L4	L5	L6	L7
20	150	25	40	80	28.5	41.5	120	80

Datasheet

Hole pattern for mounting threads and centring holes

Download CAD data → www.festo.com

DGST-20-200

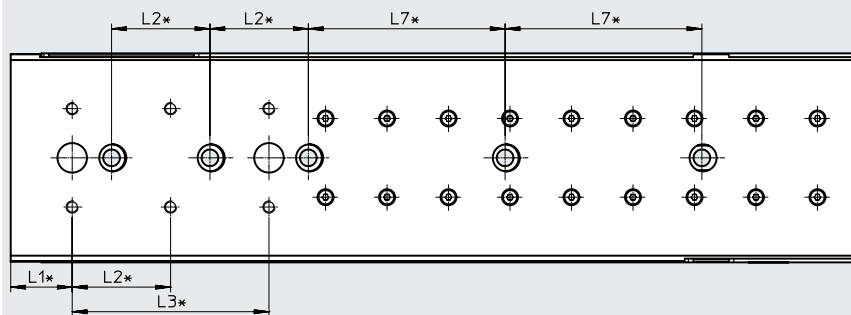
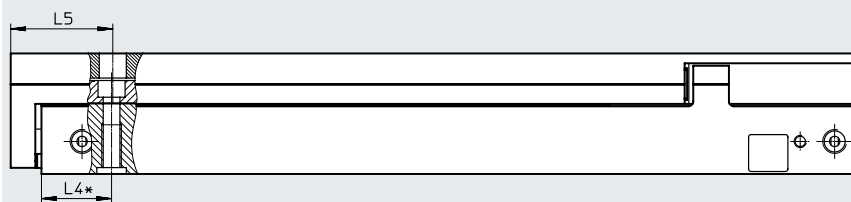
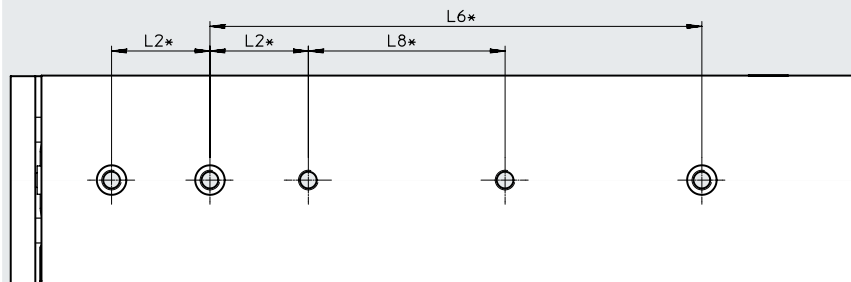

* = ±0.02 mm applies to the centring
 = ±0.1 mm applies to the thread



Size	Stroke [mm]	L1	L2	L3	L4	L5	L6	L7	L8
20	200	25	40	80	28.5	41.5	200	80	80

Datasheet

Hole pattern for mounting threads and centring holes

Download CAD data → www.festo.com

DGST-25-10/20/30/40

DGST-25-50

DGST-25-80

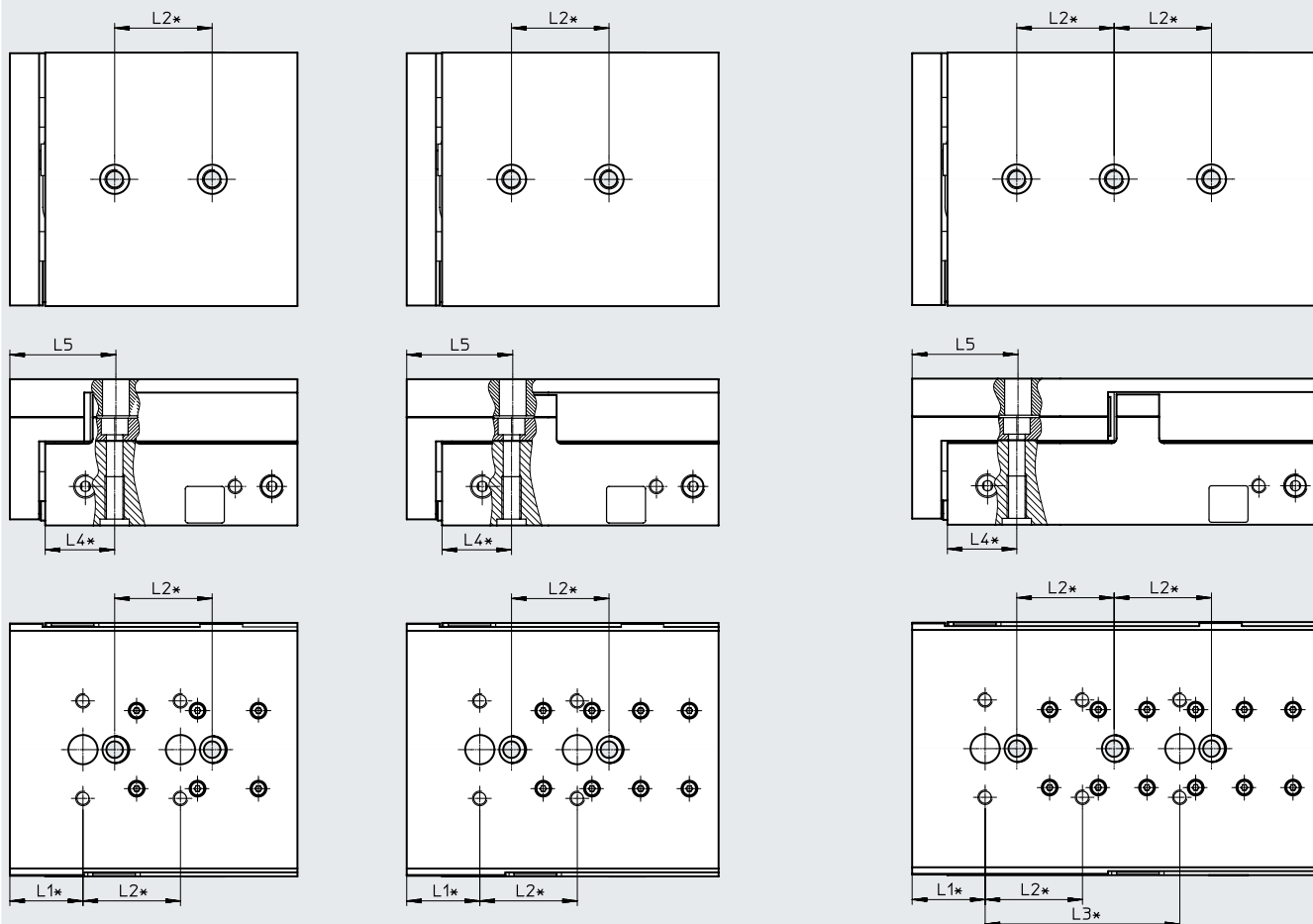

* = ±0.02 mm applies to the centring
 = ±0.1 mm applies to the thread



Size	Stroke [mm]	L1	L2	L3	L4	L5
25	10	30	40	-	28.5	43.5
	20			-		
	30			-		
	40			-		
	50			-		
	80			80		

Datasheet

Hole pattern for mounting threads and centring holes

Download CAD data → www.festo.com

DGST-25-100

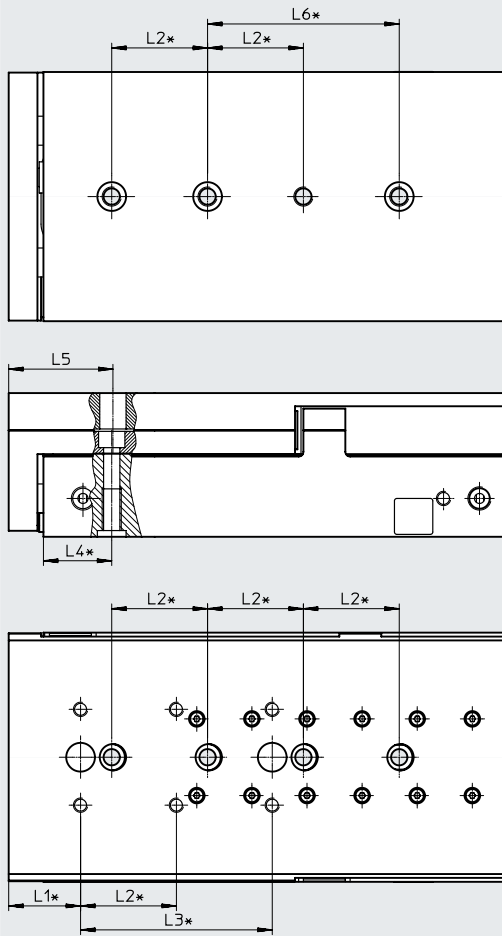

* = ± 0.02 mm applies to the centring
 = ± 0.1 mm applies to the thread



Size	Stroke [mm]	L1	L2	L3	L4	L5	L6	L7
25	100	30	40	80	28.5	43.5	80	80

Datasheet

Hole pattern for mounting threads and centring holes

Download CAD data → www.festo.com

DGST-25-125

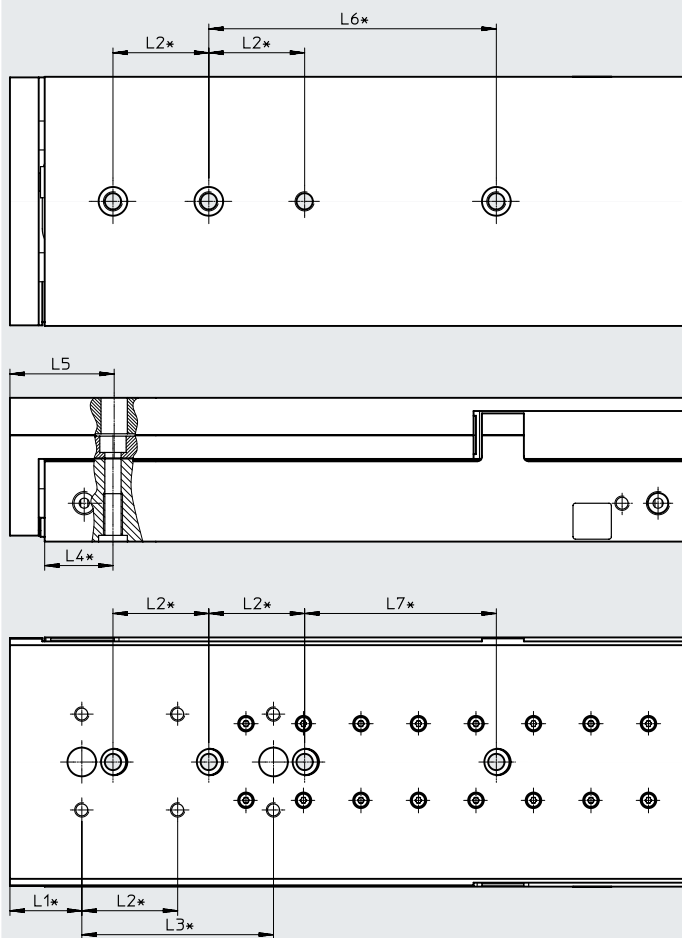

* = ± 0.02 mm applies to the centring
 = ± 0.1 mm applies to the thread



Size	Stroke [mm]	L1	L2	L3	L4	L5	L6	L7
25	125	30	40	80	28.5	43.5	120	80

Datasheet

Hole pattern for mounting threads and centring holes

Download CAD data → www.festo.com

DGST-25-150

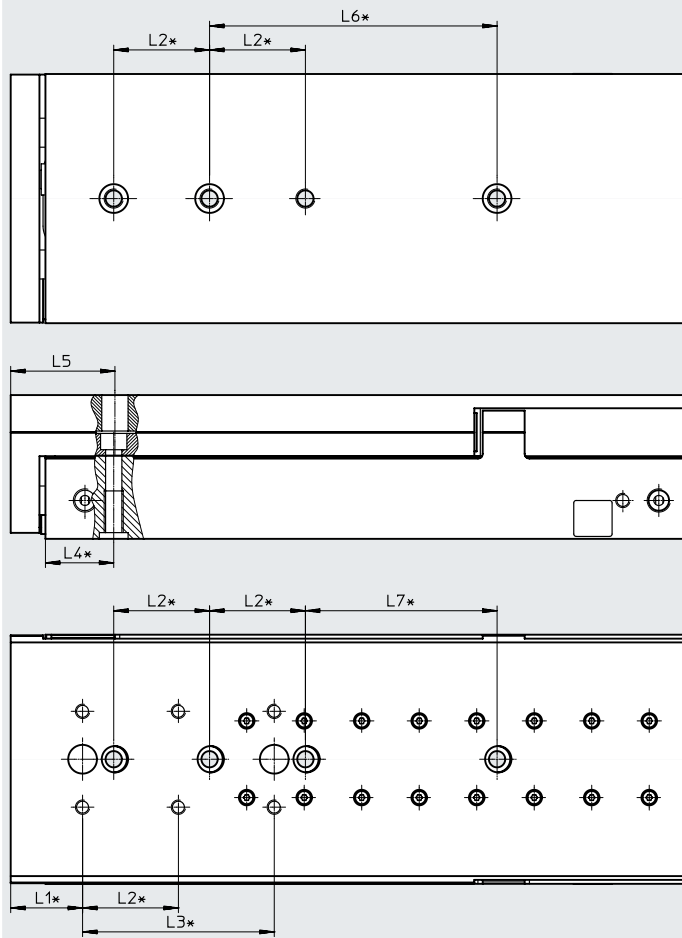

* = ± 0.02 mm applies to the centring
 = ± 0.1 mm applies to the thread



Size	Stroke [mm]	L1	L2	L3	L4	L5	L6	L7
25	150	30	40	80	28.5	43.5	120	80

Datasheet

Hole pattern for mounting threads and centring holes

Download CAD data → www.festo.com

DGST-25-200

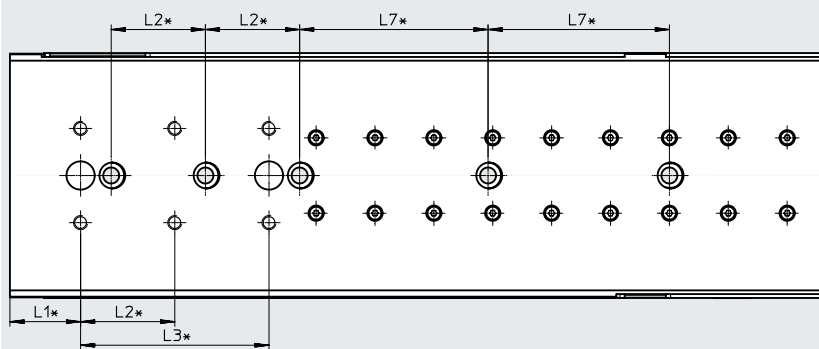
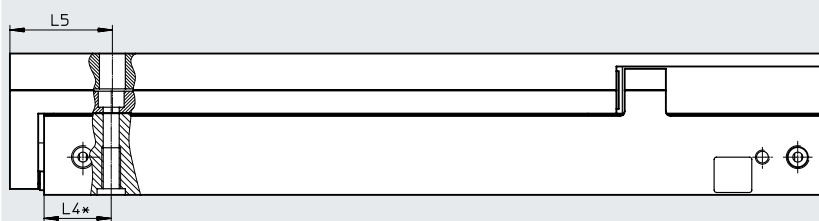
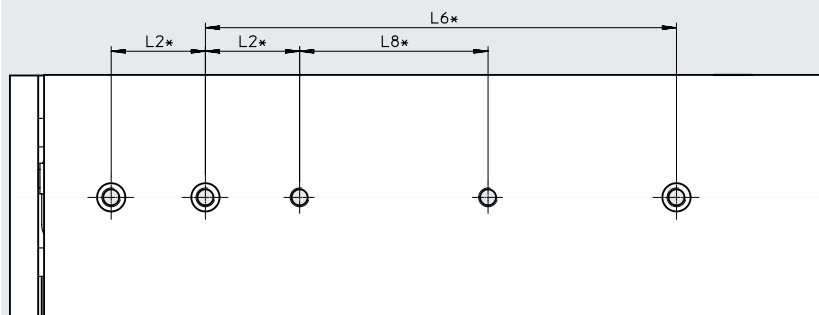

* = ±0.02 mm applies to the centring
 = ±0.1 mm applies to the thread

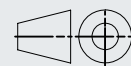

Size	Stroke [mm]	L1	L2	L3	L4	L5	L6	L7	L8
25	200	30	40	80	28.5	43.5	200	80	80

Datasheet

Dimensions

Download CAD data → www.festo.com

DGST...-P: Setting dimension and projection in the end positions

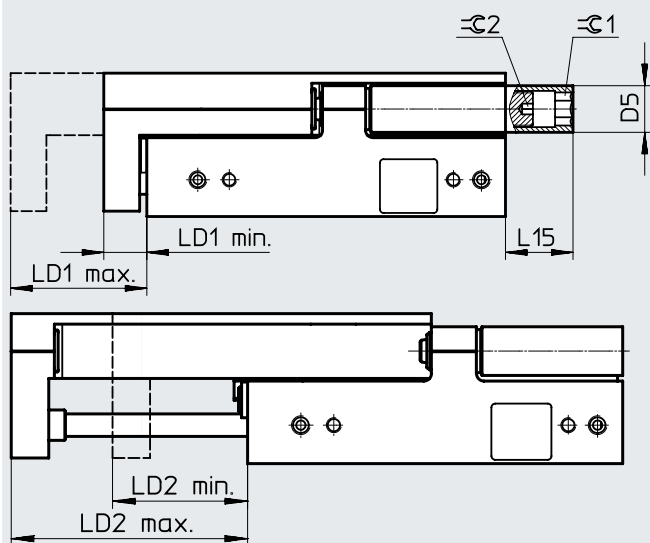

Note

Adjust and secure the cushioning components under pressure.

Size	Stroke [mm]	D5 ∅	Retracted end position LD1			Advanced end position LD2			L15	R1	R2	
			Setting range	min.	max.	Setting range	max.	min.				
6	10	6	10.4	8.6	19	10.4	19	8.6	6	3	1.5	
	20		29		15.9							
	30		11.6	20.2	13.1	39	25.9					
	40					49	35.9					
	50					59	45.9					
8	10	7	10	9.1	19.1	10	19.1	9.1	14.8	4	1.5	
	20		29.1		12.8							
	30		14.4		23.5		16.3	39.1				22.8
	40							49.1				32.8
	50							59.1				42.8
	80							89.1				72.8
10	10	8	10	11.1	21.1	10	21.1	11.1	13.9	5	2	
	20		31.1		14.4							
	30		15.1		26.2		16.7	41.1				24.4
	40							51.1				34.4
	50							61.1				44.4
	80							91.1				74.4
	100							111.1				94.4
12	10	10	10.1	10.9	21	10.1	21	10.9	15.4	6	2.5	
	20		20.1		31		20.1	31				10.9
	30		20.8		31.7		22.1	41				18.9
	40							51				28.9
	50							61				38.9
	80							91				68.9
	100							111				88.9

Datasheet

Size	Stroke [mm]	D5 ∅	Retracted end position LD1			Advanced end position LD2			L15	≅ 1	≅ 2
			Setting range	min.	max.	Setting range	max.	min.			
16	10	13	10.3	12.7	23	10.3	23	12.7	17.85	8	3
	20		20.3		33	20.3	33	12.7	20.85		
	30		21.5		34.2	22.8	43	20.2	23.85		
	40						53	30.2	18.85		
	50						63	40.2	10.85		
	80						93	70.2	0		
	100						113	90.2			
	125						138	115.2			
	150						163	140.2			
20	10	15	10.1	13.1	23.2	10.1	23.2	13.1	11.5	10	4
	20		20.1		33.2	20.1	33.2	13.1	21.5		
	30		30.1		43.2	30.1	43.2	13.1	31.5		
	40		31.1		44.2	32.9	53.2	20.3	27.5		
	50						63.2	30.3	12.5		
	80						93.2	60.3	0		
	100						113.2	80.3			
	125						138.2	105.3			
	150						163.2	130.3			
	200						213.2	180.3			
	25		10		18	10.2	15.3	25.5	10.2		
20		20.2	35.5	20.2		35.5		15.3	38.5		
30		30.2	45.5	30.2		45.5		15.3	42.5		
40		40.2	55.5	40.2		55.5		15.3	32.5		
50		45.4	60.7	47		65.5		18.5	13.5		
80						95.5		48.5	0		
100						115.5		68.5			
125						140.5		93.5			
150						165.5		118.5			
200						215.5		168.5			

Datasheet

Dimensions

Download CAD data → www.festo.com

DGST...-P1: Setting dimension and projection in the end positions

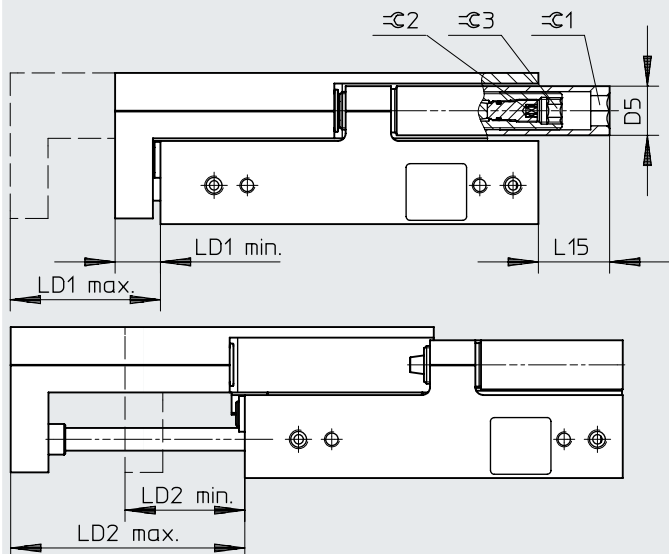

- Note

Adjust and secure the cushioning components under pressure.

Size	Stroke [mm]	D5 ∅	Retracted end position LD1			Advanced end position LD2			L15	∅ 1	∅ 2	∅ 3
			Setting range	min.	max.	Setting range	max.	min.				
6	10	6	9.9	8.6	18.5	10.35	19	8.6	6	3	1.5	2.5
	20					11.45	29	17.5				
	30						39	27.5				
	40						49	37.5				
	50						59	47.5				
8	10	7	12.3	8.7	21	10.1	18.8	8.7	14.8	4	1.5	3
	20					13.5	28.8	15.3				
	30						38.8	25.3				
	40						48.8	35.3				
	50						58.8	45.3				
	80						88.8	75.3				
10	10	8	13.3	10.7	24	10.1	20.8	10.7	14.4	5	2	4
	20					14.4	30.8	16.4				
	30						40.8	26.4				
	40						50.8	36.4				
	50						60.8	46.4				
	80						90.8	76.4				
	100						110.8	96.4				
12	10	10	17.4	10.6	28	10.2	20.8	10.6	15.4	6	2.5	5
	20					18.4	30.8	12.4				
	30						40.8	22.4				
	40						50.8	32.4				
	50						60.8	42.4				
	80						90.8	72.4				
	100						110.8	92.4				
							1.9					

Datasheet

Size	Stroke [mm]	D5 ∅	Retracted end position LD1			Advanced end position LD2			L15	⌀ 1	⌀ 2	⌀ 3
			Setting range	min.	max.	Setting range	max.	min.				
16	10	13	16.4	12.6	29	10.15	22.8	12.6	17.9	8	3	6
	20					17.4	32.8	15.35	20.9			
	30						42.8	25.35	23.9			
	40						52.8	35.35				
	50						62.8	45.35	18.9			
	80						92.8	75.35	10.9			
	100						112.8	95.35				
	125						132.8	115.35				
	150						162.8	145.35	0			

Datasheet

Dimensions

Download CAD data → www.festo.com

DGST...-E: Setting dimension and projection in the end positions

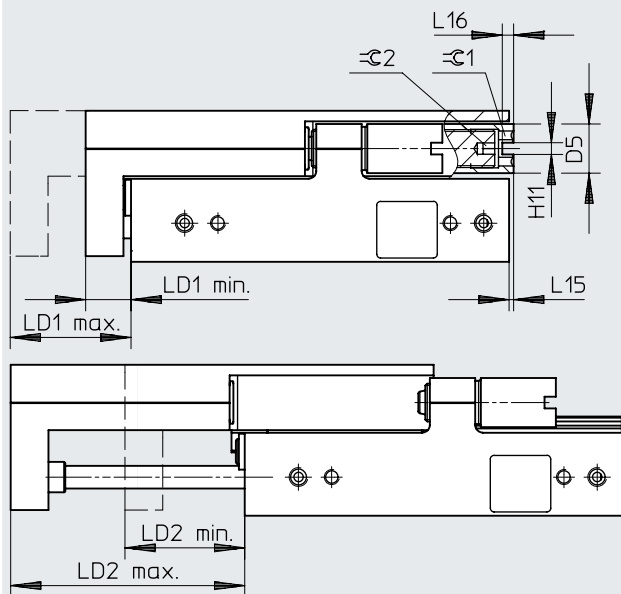

 **Note**

Adjust and secure the cushioning components under pressure.

Size	Stroke [mm]	D5 ∅	H11	Retracted end position LD1			Advanced end position LD2			L15	L16	⊕ 1	⊕ 2
				Setting range	min.	max.	Setting range	max.	min.				
6	10	6	1.6	7	9	16	8.5	19.5	11	-	1.5	3	1.5
	20							29.5	21				
	30							39.5	31				
	40							49.5	41				
	50							59.5	51				
8	10	7	1.6	6.1	9.8	15.9	6.9	19.2	12.3	-	1.5	4	1.5
	20							29.2	22.3				
	30							39.2	32.3				
	40							49.2	42.3				
	50							59.2	52.3				
10	10	8	2.1	5.6	11.7	17.3	6.3	21.3	15	-	2	5	2
	20							31.3	25				
	30							41.3	35				
	40							51.3	45				
	50							61.3	55				
12	10	10	2.6	7.4	11.3	18.7	7.6	21.4	13.8	-	2.5	6	2.5
	20							31.4	23.8				
	30							41.4	33.8				
	40							51.4	43.8				
	50							61.4	53.8				
100	80	10	2.6	7.4	11.3	18.7	7.6	91.4	83.8	-	2.5	6	2.5
	100							111.4	103.8				

Datasheet

Size	Stroke [mm]	D5 ∅	H11	Retracted end position LD1			Advanced end position LD2			L15	L16	≙ 1	≙ 2
				Setting range	min.	max.	Setting range	max.	min.				
16	10	13	3.1	6.2	13	19.2	6.4	23.4	17	6.2	3	8	3
	20							33.4	27				
	30							43.4	37				
	40							53.4	47				
	50							63.4	57				
	80							93.4	87				
	100							113.4	107				
	125							138.4	132				
	150							163.4	157				
20	10	15	4.1	6.5	13.6	20.1	7	23.5	16.5	5.5	4	10	4
	20							33.5	26.5				
	30							43.5	36.5				
	40							53.5	46.5				
	50							63.5	56.5				
	80							93.5	86.5				
	100							113.5	106.5				
	125							138.5	131.5				
	150							163.5	156.5				
	200							213.5	206.5				
	25							10	18				
20		35.8	29.5										
30		45.8	39.5										
40		55.8	49.5										
50		65.8	59.5										
80		95.8	89.5										
100		115.8	109.5										
125		140.8	134.5										
150		165.8	159.5										
200		215.8	209.5										

Datasheet

Dimensions

Download CAD data → www.festo.com

DGST...-Y12: Setting dimension and projection in the end positions

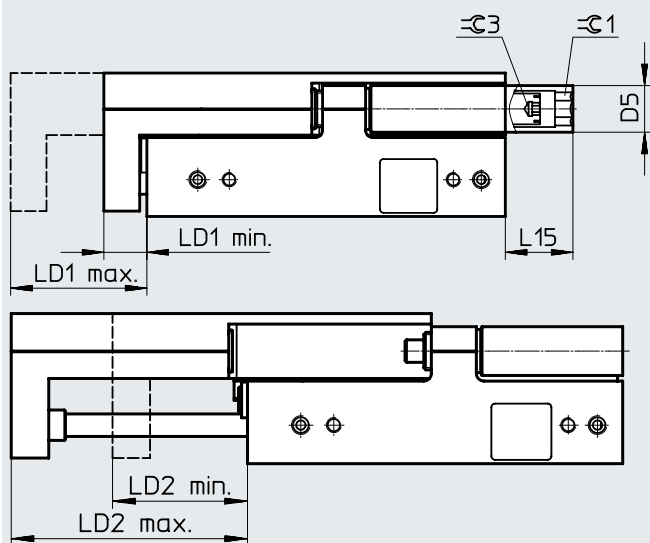

Note

Adjust and secure the cushioning components under pressure.

Size	Stroke [mm]	D5 ∅	Retracted end position LD1			Advanced end position LD2			L15	∅1	∅3
			Setting range	min.	max.	Setting range	max.	min.			
6	30	6	9.6	8.6	18.2	11.2	39	27.8	6	3	1)
	40						49	37.8			
	50						59	47.8			
8	30	7	15.7	9.1	24.8	17.6	39.1	21.5	14.8	4	2
	40						49.1	31.5			
	50						59.1	41.5			
	80						89.1	71.5			
10	30	8	14.5	11.1	25.6	16.2	41.1	24.9	13.9	5	2
	40						51.1	34.9			
	50						61.1	44.9			
	80						91.1	74.9	5.9		
	100						111.1	94.9			
12	30	10	15.2	10.9	26.1	16.7	41	24.3	15.4	6	2.5
	40						51	34.3			
	50						61	44.3			
	80						91	74.3			
	100						111	94.3			

1) There is a slot in the shock absorber for screwing it in.

Datasheet

Size	Stroke [mm]	D5 ∅	Retracted end position LD1			Advanced end position LD2			L15	≈ 1	≈ 3
			Setting range	min.	max.	Setting range	max.	min.			
16	30	13	15.5	12.7	28.2	16.9	43	26.1	23.85	8	3
	40						53	36.1			
	50						63	46.1			
	80						93	76.1	10.85		
	100						113	96.1			
	125						138	121.1	0		
	150						163	146.1			
20	30	15	22.1	13.1	35.2	22.1	43.2	21.1	31.5	10	4
	40		25.9		39	27.7	53.2	25.5			
	50						63.2	35.5			
	80						93.2	65.5	12.5		
	100						113.2	85.5	0		
	125						138.2	110.5			
	150						163.2	135.5			
	200						213.2	185.5			
25	30	18	20.2	15.3	35.5	20.2	45.5	25.3	42.5	10	4
	40		30.2		45.5	30.2	55.5	25.3			
	50		30.4		45.7	32	65.5	33.5			
	80						95.5	63.5			
	100						115.5	83.5	13.5		
	125						140.5	108.5	0		
	150						165.5	133.5			
	200		215.5		183.5						

Datasheet

Ordering data			
Size	Stroke [mm]	Part no.	Type
With cushioning E1			
6	10	8078828	DGST-6-10-E1A
	20	8078829	DGST-6-20-E1A
	30	8078830	DGST-6-30-E1A
	40	8078831	DGST-6-40-E1A
	50	8078832	DGST-6-50-E1A
8	10	8078833	DGST-8-10-E1A
	20	8078834	DGST-8-20-E1A
	30	8078835	DGST-8-30-E1A
	40	8078836	DGST-8-40-E1A
	50	8078837	DGST-8-50-E1A
10	10	8078839	DGST-10-10-E1A
	20	8078840	DGST-10-20-E1A
	30	8078841	DGST-10-30-E1A
	40	8078842	DGST-10-40-E1A
	50	8078843	DGST-10-50-E1A
	80	8078844	DGST-10-80-E1A
12	10	8078846	DGST-12-10-E1A
	20	8078847	DGST-12-20-E1A
	30	8078848	DGST-12-30-E1A
	40	8078849	DGST-12-40-E1A
	50	8078850	DGST-12-50-E1A
	80	8078851	DGST-12-80-E1A
16	10	8078853	DGST-16-10-E1A
	20	8078854	DGST-16-20-E1A
	30	8078855	DGST-16-30-E1A
	40	8078856	DGST-16-40-E1A
	50	8078857	DGST-16-50-E1A
	80	8078858	DGST-16-80-E1A
	100	8078859	DGST-16-100-E1A
	150	8078861	DGST-16-150-E1A

Size	Stroke [mm]	Part no.	Type
With cushioning P			
6	10	8085105	DGST-6-10-PA
	20	8085106	DGST-6-20-PA
	30	8085107	DGST-6-30-PA
	40	8085108	DGST-6-40-PA
	50	8085109	DGST-6-50-PA
8	10	8085110	DGST-8-10-PA
	20	8085111	DGST-8-20-PA
	30	8085112	DGST-8-30-PA
	40	8085113	DGST-8-40-PA
	50	8085114	DGST-8-50-PA
10	10	8085116	DGST-10-10-PA
	20	8085117	DGST-10-20-PA
	30	8085118	DGST-10-30-PA
	40	8085119	DGST-10-40-PA
	50	8085120	DGST-10-50-PA
	80	8085121	DGST-10-80-PA
12	10	8085123	DGST-12-10-PA
	20	8085124	DGST-12-20-PA
	30	8085125	DGST-12-30-PA
	40	8085126	DGST-12-40-PA
	50	8085127	DGST-12-50-PA
	80	8085128	DGST-12-80-PA
16	10	8085130	DGST-16-10-PA
	20	8085131	DGST-16-20-PA
	30	8085132	DGST-16-30-PA
	40	8085133	DGST-16-40-PA
	50	8085134	DGST-16-50-PA
	80	8085135	DGST-16-80-PA
	100	8085136	DGST-16-100-PA
	150	8085138	DGST-16-150-PA

Datasheet

Ordering data							
Size	Stroke [mm]	Part no.	Type	Size	Stroke [mm]	Part no.	Type
With cushioning E1				With cushioning P			
20	10	8078862	DGST-20-10-E1A	20	10	8085139	DGST-20-10-PA
	20	8078863	DGST-20-20-E1A		20	8085140	DGST-20-20-PA
	30	8078864	DGST-20-30-E1A		30	8085141	DGST-20-30-PA
	40	8078865	DGST-20-40-E1A		40	8085142	DGST-20-40-PA
	50	8078866	DGST-20-50-E1A		50	8085143	DGST-20-50-PA
	80	8078867	DGST-20-80-E1A		80	8085144	DGST-20-80-PA
	100	8078868	DGST-20-100-E1A		100	8085145	DGST-20-100-PA
	125	8078869	DGST-20-125-E1A		125	8085146	DGST-20-125-PA
	150	8078870	DGST-20-150-E1A		150	8085147	DGST-20-150-PA
	200	8078871	DGST-20-200-E1A		200	8085148	DGST-20-200-PA
25	10	8078872	DGST-25-10-E1A	25	10	8085149	DGST-25-10-PA
	20	8078873	DGST-25-20-E1A		20	8085150	DGST-25-20-PA
	30	8078874	DGST-25-30-E1A		30	8085151	DGST-25-30-PA
	40	8078875	DGST-25-40-E1A		40	8085152	DGST-25-40-PA
	50	8078876	DGST-25-50-E1A		50	8085153	DGST-25-50-PA
	80	8078877	DGST-25-80-E1A		80	8085154	DGST-25-80-PA
	100	8078878	DGST-25-100-E1A		100	8085155	DGST-25-100-PA
	125	8078879	DGST-25-125-E1A		125	8085156	DGST-25-125-PA
	150	8078880	DGST-25-150-E1A		150	8085157	DGST-25-150-PA
	200	8078881	DGST-25-200-E1A		200	8085158	DGST-25-200-PA

Datasheet

Ordering data			
Size	Stroke [mm]	Part no.	Type
With cushioning Y12			
6	30	8085159	DGST-6-30-Y12A
	40	8085160	DGST-6-40-Y12A
	50	8085161	DGST-6-50-Y12A
8	30	8085162	DGST-8-30-Y12A
	40	8085163	DGST-8-40-Y12A
	50	8085164	DGST-8-50-Y12A
	80	8085165	DGST-8-80-Y12A
10	30	8085166	DGST-10-30-Y12A
	40	8085167	DGST-10-40-Y12A
	50	8085168	DGST-10-50-Y12A
	80	8085169	DGST-10-80-Y12A
	100	8085170	DGST-10-100-Y12A
12	30	8085171	DGST-12-30-Y12A
	40	8085172	DGST-12-40-Y12A
	50	8085173	DGST-12-50-Y12A
	80	8085174	DGST-12-80-Y12A
	100	8085175	DGST-12-100-Y12A
16	30	8085176	DGST-16-30-Y12A
	40	8085177	DGST-16-40-Y12A
	50	8085178	DGST-16-50-Y12A
	80	8085179	DGST-16-80-Y12A
	100	8085180	DGST-16-100-Y12A
	125	8085181	DGST-16-125-Y12A
	150	8085182	DGST-16-150-Y12A
20	30	8085183	DGST-20-30-Y12A
	40	8085184	DGST-20-40-Y12A
	50	8085185	DGST-20-50-Y12A
	80	8085186	DGST-20-80-Y12A
	100	8085187	DGST-20-100-Y12A
	125	8085188	DGST-20-125-Y12A
	150	8085189	DGST-20-150-Y12A
	200	8085190	DGST-20-200-Y12A
25	30	8085191	DGST-25-30-Y12A
	40	8085192	DGST-25-40-Y12A
	50	8085193	DGST-25-50-Y12A
	80	8085194	DGST-25-80-Y12A
	100	8085195	DGST-25-100-Y12A
	125	8085196	DGST-25-125-Y12A
	150	8085197	DGST-25-150-Y12A
200	8085198	DGST-25-200-Y12A	

Ordering data – Modular product system

Ordering table										
Size	6	8	10	12	16	20	25	Conditions	Code	Enter code
Module no.	8073891	8073892	8073893	8073894	8073895	8073896	8073897			
Function	Mini slide								DGST	DGST
Size [mm]	6	8	10	12	16	20	25		-...	
Stroke [mm]	10	10	10	10	10	10	10		-...	
	20	20	20	20	20	20	20		-...	
	30	30	30	30	30	30	30		-...	
	40	40	40	40	40	40	40		-...	
	50	50	50	50	50	50	50		-...	
	-	80	80	80	80	80	80		-...	
	-	-	100	100	100	100	100		-...	
	-	-	-	-	125	125	125		-...	
	-	-	-	-	150	150	150		-...	
-	-	-	-	-	200	200		-...		
Version	Standard									
	Mirror-inverted								-L	
Cushioning	Elastomer cushioning, short, at both ends								-E	
	Elastic cushioning rings/plates at both ends								-P	
	Elastomer cushioning, at both ends, stroke not adjustable								-E1	
	Elastomer cushioning, adjustable at both ends, with fixed stop					-	-		-P1	
	Shock absorber, self-adjusting, linear, at both ends, external							[1]	-Y12	
Position sensing	Via proximity switch								A	
Special material properties	None									
	Recommended for production systems for manufacturing lithium-ion batteries							[2]	-F1A	
Lubrication	Standard									
	Lubrication approved for use in food applications							[3]	-H1	

1) Y12 Only in combination with a stroke of min. 30 mm

2) F1A Not in combination with E, P1, H1

3) H1 Not in combination with Y12

Accessories

Connection set DADG-AK-G8-...

Material:
 Adapter: Epoxy resin
 Seals: NBR
 Screws: Coated steel

–  Note:
 Connection kit DADG-AK-G8-... cannot
 be used in combination with
 DGST-...-L-... (mirror-inverted)

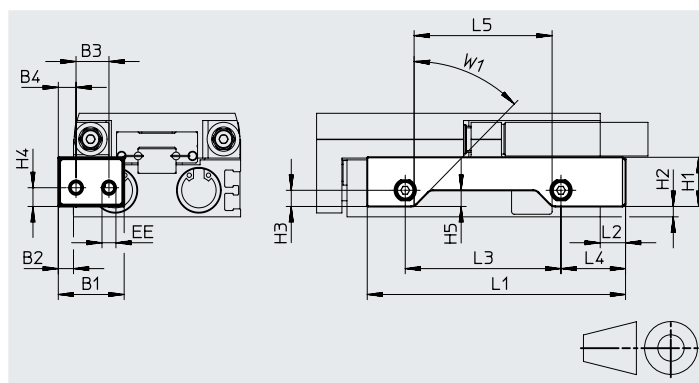

Dimensions and ordering data

For size [mm]	Stroke [mm]	B1	B2	B3	B4	EE	H1	H2	H3	H4	H5
6	20 ... 50	21	4	10.5	5.5	M5	11.6	0.1	4.4	5	2.9
	20	26	6	13	6.5	M5	13.6	0.3	5.3	5.2	3.3
30 ... 80	5.3										
10	10 ... 20	26	6	13	6.5	M5	16.1	0.7	6.4	6.4	3.9
	30 ... 100										6.4
12	10	26	6	13	6.5	M5	18.4	2.6	6.4	6.4	3.9
	20 ... 100										6.4

For size [mm]	Stroke [mm]	L1	L2	L3	L4	L5	W1	CRC ¹⁾	Weight [g]	Part no.	Type
6	20	53.5	8	21.9	20.7	17	45°	1	4.7	8152357	DADG-AK-G8-6-20
	30	63.5		31.9		27		1	5.1	8152358	DADG-AK-G8-6-30
	40	73.5		41.9		37		1	5.4	8152359	DADG-AK-G8-6-40
	50	90.5		58.9		54		1	6	8152360	DADG-AK-G8-6-50
8	20	61	10	23	23.5	17.4		1	8.3	8152361	DADG-AK-G8-8-20
	30	71		33		27.4		1	8.7	8152362	DADG-AK-G8-8-30
	40	81		43		37.4		1	9.2	8152363	DADG-AK-G8-8-40
	50	95		57		51.4		1	9.9	8152364	DADG-AK-G8-8-50
	80	126		88		82.4		1	11.3	8152365	DADG-AK-G8-8-80
10	10	64	10	22.5	25.6	16.7		1	11	8152366	DADG-AK-G8-10-10
	20	66		24.5		18.7		1	11.2	8152367	DADG-AK-G8-10-20
	30	76		34.5		28.7		1	11.6	8152368	DADG-AK-G8-10-30
	40	86		44.5		38.7		1	12.1	8152369	DADG-AK-G8-10-40
	50	96		54.5		48.7		1	12.6	8152370	DADG-AK-G8-10-50
	80	134		92.5		86.7		1	14.5	8152371	DADG-AK-G8-10-80
12	100	154	112.5	106.7	1	15.5		8152372	DADG-AK-G8-10-100		
	10	62	10	20.7	25.8	14.9	1	12.2	8152373	DADG-AK-G8-12-10	
	20	72		30.7		24.9	1	12.9	8152374	DADG-AK-G8-12-20	
	30	82		40.7		34.9	1	13.6	8152375	DADG-AK-G8-12-30	
	40	92		50.7		44.9	1	14.2	8152376	DADG-AK-G8-12-40	
	50	102		60.7		54.9	1	14.9	8152377	DADG-AK-G8-12-50	
	80	132		90.7		84.9	1	16.9	8152378	DADG-AK-G8-12-80	
	100	165.5		124.2		118.4	1	19.2	8152379	DADG-AK-G8-12-100	

1) More information: www.festo.com/x/topic/crc

Accessories

Dimensions and ordering data											
For size [mm]	Stroke [mm]	B1	B2	B3	B4	EE	H1	H2	H3	H4	H5
16	10 ... 20	26	6	13	7	M5	19	4	6.3	7.3	3.6
	30 ... 100										6.3
	125 ... 150										2
20	10 ... 30	45	9	22	13	G1/8	24.8	3.7	9.5	9.5	5.5
	40 ... 150		10								9.5
	200		8.6								
25	10 ... 30	45	9	22	13	G1/8	28.2	6.5	9.5	9.5	5
	40 ... 150		10								9.5
	200		12								

Size [mm]	Stroke [mm]	L1	L2	L3	L4	L5	W1	CRC ¹⁾	Weight [g]	Part no.	Type
16	10	63	10	22.5	25.5	15.5	45°	1	12.9	8152380	DADG-AK-G8-16-10
	20	70		29.5		22.5		1	13.5	8152381	DADG-AK-G8-16-20
	30	77		36.5		29.5		1	13.8	8152382	DADG-AK-G8-16-30
	40	87		46.5		39.5		1	14.5	8152383	DADG-AK-G8-16-40
	50	102		61.5		54.5		1	15.5	8152384	DADG-AK-G8-16-50
	80	140		100.5	24.5	93.5		1	17.8	8152385	DADG-AK-G8-16-80
	100	160		120.5		113.5		1	19.1	8152386	DADG-AK-G8-16-100
	125	200		160.5		153.5		1	28.2	8159793	DADG-AK-G8-16-125
	150	225		185.5		178.5		1	31	8159794	DADG-AK-G8-16-150
								1	36.3	8152389	DADG-AK-G8-20-10/30
20	10/20/30	92.6	15	32	37	23.4	45°	1	36.3	8152389	DADG-AK-G8-20-10/30
	40	102.6		42		33.4		1	37.5	8152390	DADG-AK-G8-20-40
	50	116.6		56		47.4		1	39.2	8152391	DADG-AK-G8-20-50
	80	161.6		101		92.4		1	44.7	8152392	DADG-AK-G8-20-80
	100	200.1		139.5		130.9		1	49.4	8159795	DADG-AK-G8-20-100
	125	239.6		179		170.4		1	54.2	8159796	DADG-AK-G8-20-125
	150	274.6		214		205.4		1	58.6	8159797	DADG-AK-G8-20-150
	200	338.6		278		270.1		1	80.2	8159882	DADG-AK-G8-20-200
25	10/20	95.6	15	30.5	40.5	22.6	45°	1	43.7	8152397	DADG-AK-G8-25-10/20
	30	101.6		36.5		28.6		1	44.8	8152398	DADG-AK-G8-25-30
	40	111.6		46.5		38.6		1	46.1	8152399	DADG-AK-G8-25-40
	50	121.6		56.5		48.6		1	47.5	8152400	DADG-AK-G8-25-50
	80	161.6		96.5		88.6		1	53.4	8152401	DADG-AK-G8-25-80
	100	200.6		135.5		127.6		1	59	8159816	DADG-AK-G8-25-100
	125	239.6		174.5		166.6		1	64.7	8159817	DADG-AK-G8-25-125
	150	274.6		209.5		201.6		1	69.8	8159818	DADG-AK-G8-25-150
	200	338.6		273.5		265.5		1	87.7	8159883	DADG-AK-G8-25-200

1) More information: www.festo.com/x/topic/crc

Accessories

Intermediate-position module DADM

Material:
Housing:
Wrought aluminium alloy
Lever:
High-alloy stainless steel
RoHS-compliant

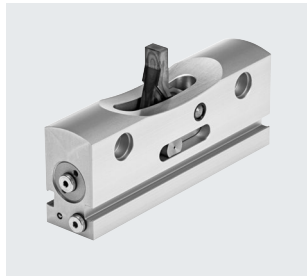

Dimensions and ordering data

Datasheets → Internet: dadm

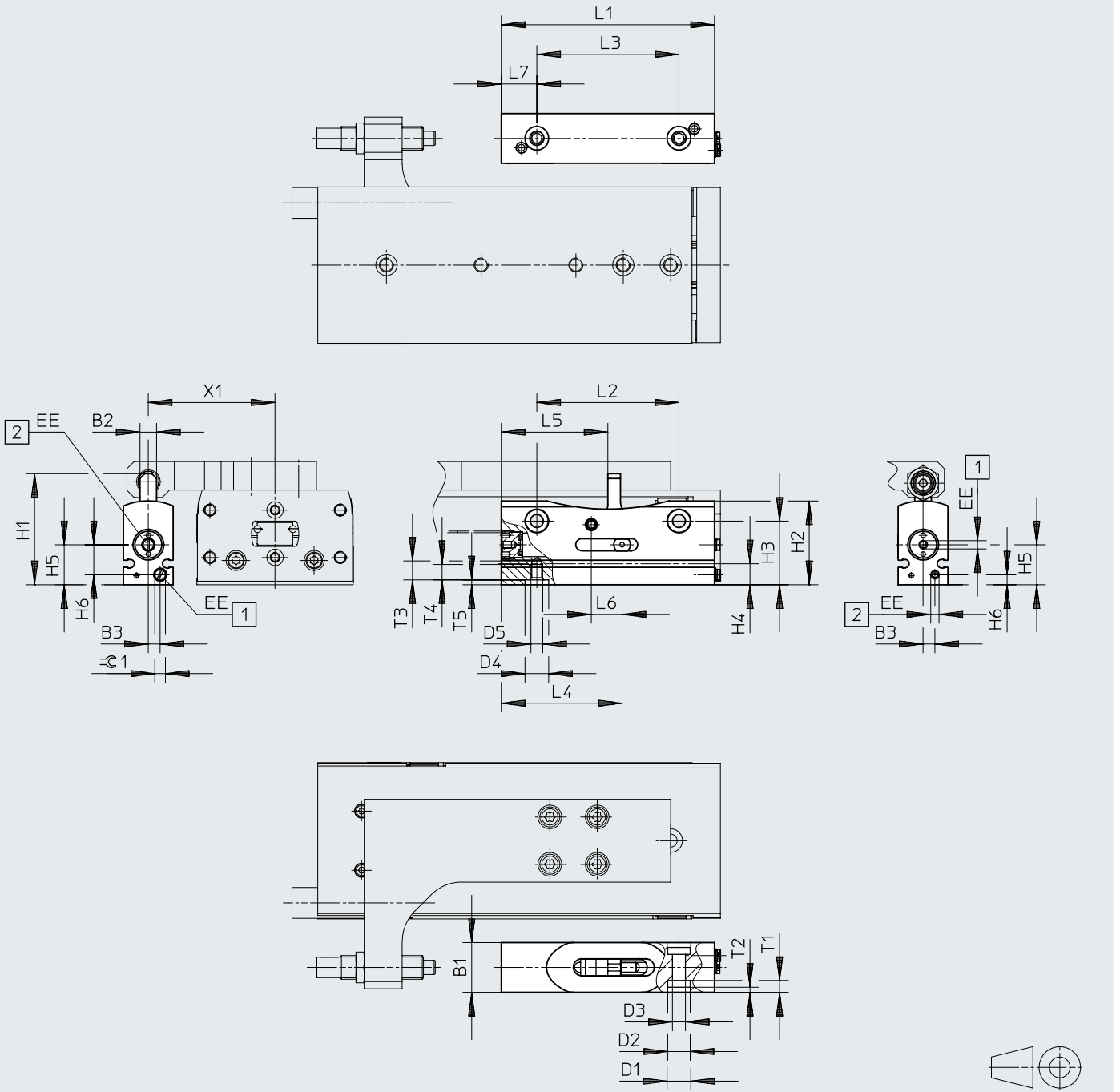

- [1] Swivel stop lever inwards
- [2] Swivel stop lever outwards



Note
With DADM-EP-G6-10: SME/SMT-10
With DADM-EP-G6-16: SME/SMT-8

Accessories

For size	B1	B2	B3	D1 ∅ H7	D2 ∅	D3 ∅	D4 ∅ H7	D5	EE	H1	H2
12, 16	21	7	5	10	9.5	5.5	10	M5	M3	46.9	35.4
20, 25	26.5	9	5.5	12	11	6.6	12	M6	M5	65.2	47.4

For size	H3 ±0.1	H4	H5 ±0.1	H6 ±0.1	L1	L2 ±0.05	L3 ±0.05	L4	L5	L6	L7
12, 16	26.9	8.9	16.9	12.7	90	60	60	51	45	12	15
20, 25	36.4	12.4	23.4	17	120	80	80	68	60	16	20

For size	T1	T2 ±0.05	T3	T4	T5 ±0.05	X1 +0.2	≈G1	Weight [g]	Part no.	Type
12	5	2.15	8	6.5	2.15	50.5	4.5	154	1492072	DADM-EP-G6-10
16										
20	6.8	2.65	10	8	2.65	70.8	2.5	340	1478121	DADM-EP-G6-16
25										

Ordering data										
For size	Description							Part no.	Type	PU ¹⁾
Connector sleeve ZBV Datasheets → Internet: zbv										
	12, 16	For centring the intermediate-position module (2 pieces included in the scope of delivery for the intermediate-position module)						560254	ZBV-10-9	10
Centring sleeve ZBH Datasheets → Internet: zbh										
	20, 25	For centring the intermediate-position module (2 pieces included in the scope of delivery for the intermediate-position module)						8137185	ZBH-12-B	10

1) Packaging unit

Assembly

To ensure that the shock absorber hits the middle of the stop lever, the following spacing must be complied with:
 DGST-12/16: 10 mm
 DGST-20/25: 15 mm
 It is fastened on the mounting surface using 2 screws and centring sleeves. The shock absorber retainer is then attached to the slide of the mini slide using 4 screws and 2 centring sleeves.

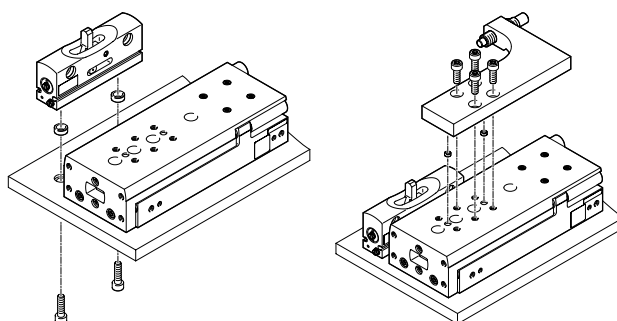

Precision adjustment:

The position can be precisely adjusted via the screw-in depth of the shock absorber. The shock absorber must protrude by at least 1.5 mm.

Accessories

Shock absorber retainer DADP

Material:
Anodised wrought aluminium alloy
RoHS-compliant

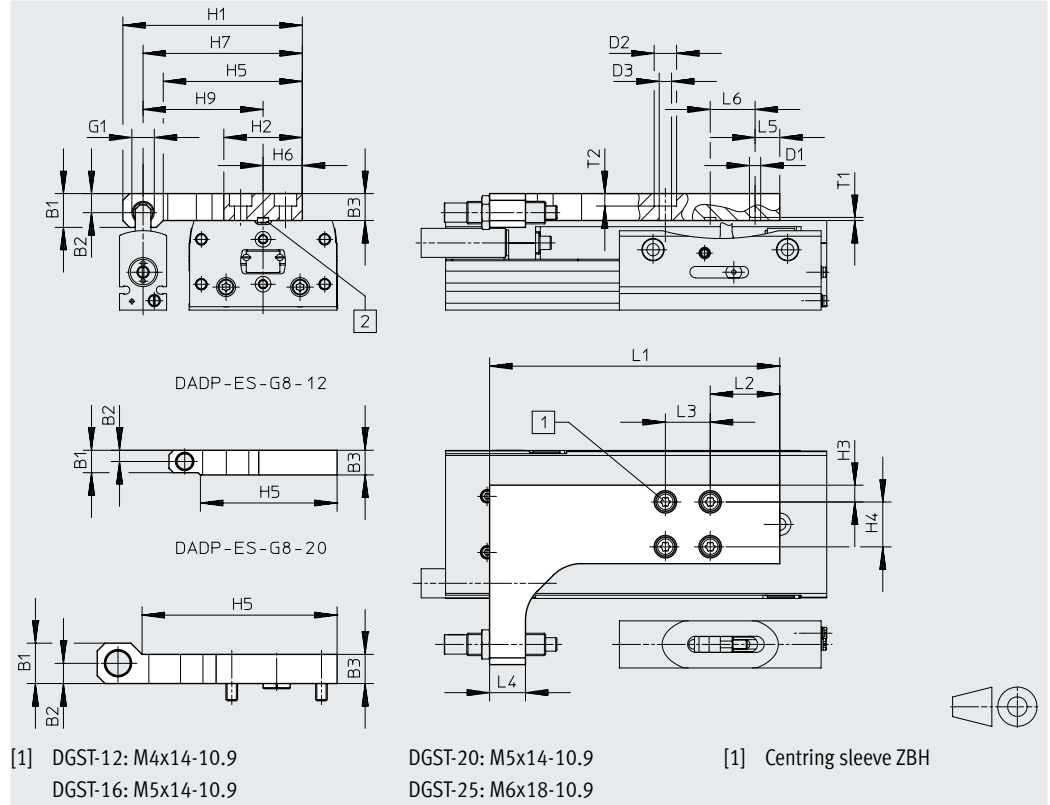
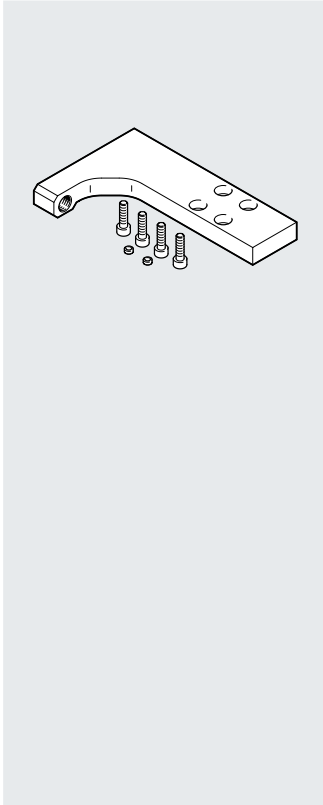

[1] DGST-12: M4x14-10.9
DGST-16: M5x14-10.9

DGST-20: M5x14-10.9
DGST-25: M6x18-10.9

[1] Centring sleeve ZBH

Dimensions and ordering data

For size	B1 ±0.1	B2	B3 ±0.1	H1	H2	H3	H4	H5	H6	H7	H9	D1 ∅	D2 ∅	D3 ∅	G1
12	10	5	11	75	35	7.5	20	61	17.5	68	50.5	5 ^{H7}	8	4.5	M8x1
16	15.1	8.5	12	80	35	7.5	20	62	17.5	71	53.5	5 ^{H7}	10	5.5	M10x1
20	18	9	13	107	54	7	40	87	27	97.8	70.8	12 ^{H7}	10	5.5	M12x1
25	24.6	15.6	14	126	70	15	40	90	35	115.3	80.3	12 ^{H7}	11	6.6	M14x1

For size	L1	L2	L3	L4	L5	L6	T1 ±0.05	T2	Weight [g]	Part no.	Type
12	119.9	25	20	16	5	3x20	1.35	4.4	151	8159234	DADP-ES-G8-12
16	129.4	31	20	16	11	3x20	1.35	5.6	182	8159235	DADP-ES-G8-16
20	131	8	40	25	8	2x40	2.65	6.6	307	8159236	DADP-ES-G8-20
25	150.5	10.5	40	32	10.5	2x40	2.65	6.4	506	8159237	DADP-ES-G8-25

Ordering data

For size	Description	Part no.	Type	PU ¹⁾	
Centring sleeve ZBH					
Datasheets → Internet: zbh					
	12, 16	For centring the shock absorber retainer (2 pieces included in the scope of delivery of the shock absorber retainer)	8146543	ZBH-5-B	10
	20, 25		8137185	ZBH-12-B	

1) Packaging unit

Note

- A shock absorber retainer DADP-ES is additionally required when using an intermediate-position module
- Operation without cushioning components is not permitted
- Cushioning components are not included in the scope of delivery
- The size of the shock absorbers for the mini slides and for the relevant shock absorber retainer are identical. Shock absorber selection → page 55
- The same cushioning component as is used in the end positions of the mini slide is used for cushioning the intermediate position

Accessories

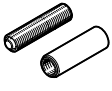
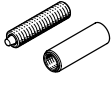
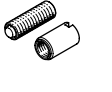
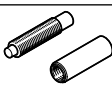
Ordering data – Shock absorbers						
	For size	Description	Part no.	Type		
For DGST...-P					Datasheets → Internet: dyef	
	6	<ul style="list-style-type: none"> • Scope of delivery: 1 cushioning component and 1 threaded sleeve • Elastic cushioning rings/plates at both ends • Included in the scope of delivery for DGST...-P (pack of 2) 	8073902	DYEF-G8-M4-Y1		
	8		8131070	DYEF-G8-M4-Y1-F1A		
	10		8073903	DYEF-G8-M5-Y1		
	12		8131071	DYEF-G8-M5-Y1-F1A		
	16		8073904	DYEF-G8-M6-Y1		
	20		8131072	DYEF-G8-M6-Y1-F1A		
	25		8073905	DYEF-G8-M8-Y1		
			8131073	DYEF-G8-M8-Y1-F1A		
			8073906	DYEF-G8-M10-Y1		
			8131074	DYEF-G8-M10-Y1-F1A		
For DGST...-P1					Datasheets → Internet: dyef	
	6	<ul style="list-style-type: none"> • Scope of delivery: 1 cushioning component and 1 threaded sleeve • Elastomer cushioning, adjustable at both ends, with fixed stop • Included in the scope of delivery for DGST...-P1 (pack of 2) 	8160234	DYEF-G8-M4-Y1F		
	8		8160235	DYEF-G8-M5-Y1F		
	10		8160236	DYEF-G8-M6-Y1F		
	12		8160237	DYEF-G8-M8-Y1F		
	16		8160238	DYEF-G8-M10-Y1F		
For DGST...-E					Datasheets → Internet: dyef	
	6	<ul style="list-style-type: none"> • Scope of delivery: 1 cushioning component and 1 threaded sleeve • Elastomer cushioning, short, at both ends • Included in the scope of delivery for DGST...-E (pack of 2) 	8159470	DYEF-G8-S-M4-Y1		
	8		8159471	DYEF-G8-S-M5-Y1		
	10		8159472	DYEF-G8-S-M6-Y1		
	12		8159473	DYEF-G8-S-M8-Y1		
	16		8159474	DYEF-G8-S-M10-Y1		
	20		8159475	DYEF-G8-S-M12-Y1		
	25		8159476	DYEF-G8-S-M14-Y1		
For DGST...-Y12					Datasheets → Internet: dyss	
	6	<ul style="list-style-type: none"> • Scope of delivery: 1 cushioning component and 1 threaded sleeve • Shock absorber, self-adjusting, linear, at both ends, external • Included in the scope of delivery for DGST...-Y12 (pack of 2) • Only possible from a stroke of 30 mm • Set minimum stroke ≥ 2x cushioning length 	8073911	DYSS-G8-2-4-Y1F		
	8		8119980	DYSS-G8-2-4-Y1F-F1A		
	10		8111383	DYSS-G8-3-4-Y1F-G2		
	12		8119981	DYSS-G8-3-4-Y1F-F1A-G2		
	16		8111384	DYSS-G8-4-4-Y1F-G2		
	20		8119982	DYSS-G8-4-4-Y1F-F1A-G2		
	25		8073914	DYSS-G8-5-5-Y1F		
			8119983	DYSS-G8-5-5-Y1F-F1A		
			8073915	DYSS-G8-7-5-Y1F		
			8119984	DYSS-G8-7-5-Y1F-F1A		
			8073916	DYSS-G8-8-8-Y1F		
			8132349	DYSS-G8-8-8-Y1F-F1A		
			8073917	DYSS-G8-10-10-Y1F		
	8132350	DYSS-G8-10-10-Y1F-F1A				

Monitoring with distance sensor SOIA





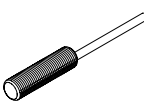

To monitor the application and condition of the damping elements. Enables predictive maintenance and increases reliability and accuracy.

The following parameters can be monitored:

- Impact velocity
- End position
- Energy consumption
- Residual energy
- Damping reserve

Distance sensor SOIA, inductive						
	Mounting type	Displacement measuring range	Switching output	Electrical connection	Part no.	Type
	Flush	0 ... 2 mm	PNP/NPN, switchable, Push-pull	Open end	8161194	SOIA-M8PB-PNLK-LE
		0 ... 4 mm			8161198	SOIA-M12PB-PNLK-LE
	Not flush	0 ... 7 mm			8161196	SOIA-M8PNB-PNLK-LE
					8161200	SOIA-M12PNB-PNLK-LE

Accessories

Ordering data			Part no.	Type	PU ¹⁾	
For size	Description					
Centring sleeve/Centring pin ZBH, ZBS Datasheets → Internet: zbh						
	6, 8, 10, 12, 16	For centring loads and attachments on the slide	8146543	ZBH-5-B	10	
	20, 25		8137185	ZBH-12-B		
	6	For centring loads and attachments on the yoke plate	525273	ZBS-2		
	8, 10		8146543	ZBH-5-B		
	12, 16		8146544	ZBH-7-B		
	20, 25		8137185	ZBH-12-B		
	6, 8		For centring the mini slide during mounting	8119593		ZBH-5-M4
	10, 12			8146544		ZBH-7-B
	16	8137184		ZBH-9-B		
	20, 25	8137185	ZBH-12-B			
Connector sleeve ZBV Datasheets → Internet: zbv						
	20	For centring loads and attachments on the yoke plate	548806	ZBV-12-9	10	
One-way flow control valve GRLA Datasheets → Internet: grla						
	6	For regulating speed	175041	GRLA-M3-QS-3	1	
	8, 10, 12, 16		193139	GRLA-M5-QS-6-D		
	20, 25		193145	GRLA-1/8-QS-8-D		
One-way flow control valve GRLA for connection kit DADG-AK-G8-... Datasheets → Internet: grla						
	6	For regulating speed	175053	GRLA-M5-QS-3-LF-C	1	
	8, 10, 12, 16		193139	GRLA-M5-QS-6-D		
	20, 25		193145	GRLA-1/8-QS-8-D		
Push-in fitting QSM Datasheets → Internet: qs						
	6	For connecting tubing with standard O.D.	153303	QSM-M3-4	10	
	8, 10, 12, 16		153304	QSM-M5-4		
	20, 25		153307	QSM-1/8-6		
Push-in fitting QSM for connection kit DADG-AK-G8-... Datasheets → Internet: qs						
	6	For connecting tubing with standard O.D.	153302	QSM-M5-3	10	
			153313	QSM-M5-3-I		
	8, 10, 12, 16		153304	QSM-M5-4		
	20, 25		153307	QSM-1/8-6		

1) Packaging unit

Accessories

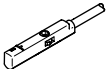
Proximity switch for size 6 ... 12						
Ordering data – Proximity switch for C-slot, magneto-resistive						Datasheets → Internet: smt
	Type of mounting	Switching output	Electrical connection, Outlet direction of connection	Cable length [m]	Part no.	Type
N/O						
	Inserted in the slot from above	PNP	Cable, 3-core, lengthwise	2.5	551373	SMT-10M-PS-24V-E-2.5-L-OE
			Plug M8x1, 3-pin, in-line	0.3	551375	SMT-10M-PS-24V-E-0.3-L-M8D
			Plug M8x1, 3-pin, crosswise	0.3	551376	SMT-10M-PS-24V-E-0.3-Q-M8D
		NPN	Cable, 3-wire	2.5	551377	SMT-10M-NS-24V-E-2.5-L-OE
			Cable, 3-wire	2.5	551378	SMT-10M-NS-24V-E-2.5-Q-OE
			Plug M8x1, 3-pin, in-line	0.3	551379	SMT-10M-NS-24V-E-0.3-L-M8D
			Plug M8x1, 3-pin, crosswise	0.3	551380	SMT-10M-NS-24V-E-0.3-Q-M8D

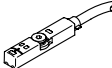
Proximity switch for size 16 ... 25						
Ordering data – Proximity switch for T-slot, magneto-resistive						Datasheets → Internet: smt
	Type of mounting	Switching output	Electrical connection	Cable length [m]	Part no.	Type
N/O						
	Inserted in the slot from above, flush with the cylinder profile, short design	PNP	Cable, 3-core	2.5	574335	SMT-8M-A-PS-24V-E-2.5-OE
			Plug M8x1, 3-pin	0.3	574334	SMT-8M-A-PS-24V-E-0.3-M8D
		NPN	Cable, 3-core	2.5	574338	SMT-8M-A-NS-24V-E-2.5-OE
			1x M8 plug, 3-pin	0.3	574339	SMT-8M-A-NS-24V-E-0.3-M8D

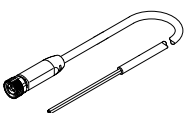
Connecting cables NEBA, straight						
	Electrical connection 1, connection technology	Electrical connection 2, connection technology	Electrical connection 2, number of pins/cores	Cable length	Part no.	Type
	M8x1 A-coded to EN 61076-2-104	Open end	3	2.5 m	8078223	NEBA-M8G3-U-2.5-N-LE3
				5 m	8078224	NEBA-M8G3-U-5-N-LE3

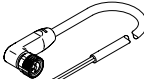
Connecting cables NEBA, angled						
	Electrical connection 1, connection technology	Electrical connection 2, connection technology	Electrical connection 2, number of pins/cores	Cable length	Part no.	Type
	M8x1 A-coded to EN 61076-2-104	Open end	3	2.5 m	8078230	NEBA-M8W3-U-2.5-N-LE3
				5 m	8078231	NEBA-M8W3-U-5-N-LE3

Accessories

Position transmitter

The position transmitter continuously senses the position of the piston.

It has an analogue output with an output signal that is proportional to the piston position.

Ordering data – Position transmitter for T-slot

Datasheets → Internet: position transmitter

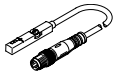
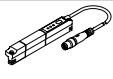
	For \varnothing	Position measuring range	Analogue output		Type of mounting	Electrical connection	Cable length [m]	Part no.	Type
			[V]	[mA]					
	16 ... 25	0 ... 40	0 ... 10	–	Inserted in the slot from above	Plug M8x1, 4-pin, in-line	0.3	553744	SMAT-8M-U-E-0.3-M8D
	16 ... 25	0 ... 50	–	4 ... 20	Inserted in the slot from above	Plug M8x1, 4-pin, in-line	0.3	1531265	SDAT-MHS-M50-1L-SA-E-0.3-M8
		0 ... 80						1531266	SDAT-MHS-M80-1L-SA-E-0.3-M8
		0 ... 100						1531267	SDAT-MHS-M100-1L-SA-E-0.3-M8
		0 ... 125						1531268	SDAT-MHS-M125-1L-SA-E-0.3-M8
		0 ... 160						1531269	SDAT-MHS-M160-1L-SA-E-0.3-M8

Ordering data – Position transmitter for T-slot

Datasheets → Internet: sdas

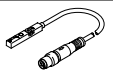
	Position measuring range	Description	Type of mounting	Electrical connection	Cable length [m]	Part no.	Type
	For \varnothing 16: ≤ 28	Choice of two operating modes: two adjustable switching outputs IO-Link®	Inserted in the slot from above	Plug M8x1, 4-pin, in-line	0.3	8063974	SDAS-MHS-M40-1L-PNLK-PN-E-0.3-M8
	For \varnothing 20, 25: ≤ 32			Cable, open end	2.5	8063975	SDAS-MHS-M40-1L-PNLK-PN-E-2.5-LE

Connecting cables NEBA, straight

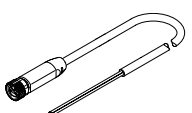
	Electrical connection 1, connection technology	Electrical connection 2, connection technology	Electrical connection 2, number of pins/cores	Cable length	Part no.	Type
	M8x1 A-coded to EN 61076-2-104	Open end	4	2.5 m	8078227	NEBA-M8G4-U-2.5-N-LE4
				5 m	8078228	NEBA-M8G4-U-5-N-LE4

Connecting cables NEBA, angled

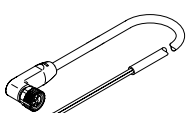
	Electrical connection 1, connection technology	Electrical connection 2, connection technology	Electrical connection 2, number of pins/cores	Cable length	Part no.	Type
	M8x1 A-coded to EN 61076-2-104	Open end	4	2.5 m	8078233	NEBA-M8W4-U-2.5-N-LE4
				5 m	8078234	NEBA-M8W4-U-5-N-LE4