

# Industrial Cameras

## STC/FS Series



# Make It Faster, Make It Simpler

OMRON has been developing high speed & high performance image processing systems in order to meet the needs of the automation world pursues. And now, image processing began to spread all over the world and the evolution speed of people want is getting higher. For our customers' satisfaction, we start to deliver OMRON SENTECH (former SENTECH)'s cameras. OMRON SENTECH is a manufacturer specializing in industrial cameras that became a new member of the OMRON group. Those cameras make the conventional systems simpler, faster and more flexible. Also they make it easy to assist the visual inspection to capture enlarged images without pc.

**OMRON** **SENTECH**



## Notes for Purchase

- Please contact the trading company for delivery date.
- All cameras in this catalog can not be connected to the image processing system such as FH / FZ / FJ series

# How to Choose a camera Camera Line-up Chart



## Per-interface comparison table Camera Line-up Chart

Pages 3 - 4

How to Choose a camera

### GigE Vision



\* The M Series measures 29 x 29 mm. The S Series measures 35 x 35 mm.

CMOS M Series

Pages 5 - 6

CMOS S Series

Pages 7 - 8

GigE

### USB



USB3.0

Pages 9 - 12

USB3.0 Remote Head

Pages 13 - 14

USB

### CameraLink Over



CoaXPress

Pages 15 - 16

Opt-C:Link

Pages 17 - 18

CameraLink Over

### CameraLink



CMOS

Pages 19 - 22

CameraLink

### HDMI/DVI/SDI



4K HDMI

Pages 23 - 24

DVI

Pages 25 - 26

HD-SDI

Pages 27 - 28

HDMI/DVI/SDI

### Analog Progressive



Analog Progressive

Pages 29 - 30

Analog Progressive

### Color TV Format



S133N-B Series

Pages 31 - 32

Color TV Format

### Small Board Camera



S133N(P)/S133UVC/S133MIP Series Pages 33 - 38

Small Board Camera

### Line Scanning Camera



CameraLink

Pages 39 - 42

Line Scanning Camera

### Accessories



Cable, Others

Pages 43 - 44

Fixed Focus Lens

Page 45

4ch USB Board

Page 46

Spectral Sensitivity Characteristics Pages 47 - 52

Accessories

# How to Choose a Camera

## Camera Line-up Chart



### How to Choose an Image Sensor

- Monochrome
  - Mono or Color?
- Number of Pixels
  - Optimal Resolution for Your Application
- Scan Speed
  - Required FPS
- Sensor Size?

### How to Choose the Interface

- Connect to
  - Monitor or PC?
- Cable Length
  - Distance Between the Camera and the Equipment
- The Number of Cameras
  - How many cameras for one PC?

Based on factors such as decided specifications, system outline and cost image, refer to the following per-interface comparison table and product lineup chart to choose the optimum Sentech camera.

■ Interface when using a PC / 
 ■ Interface when not using a PC / 
 ■ Interface not offered by OMRON

Interfaces	GigE Vision®	USB		CoaXpress	Opt-C:Link	Camera Link		Analog	HD-DVI	HD-SDI	TV Formats	IEEE1394b	Camera Link HS
		USB2.0	USB3.0			Base	Full						
Monitor Display	PC Required						PC Required		Can be connected directly to monitor			PC Required	PC Required
Connection Port	Gigabit Ethernet Port	USB2.0 Port	USB3.0 Port	CoaXpress Grabber Board	Opt-C:Link Grabber Board	Camera Link Frame Grabber Board		Analog Frame Grabber Board	HDMI Port DVI Port	SDI connector	RCA connector BNC connector	Required	CameraLink HS Grabber Board
Cable	Ethernet cable Cat 5e or higher	USB2.0 Cable	USB3.0 Cable	Coaxial Cable	Optical cable	Camera Link Cable		12-pin Cable	HDMI/DVI Cable	Coaxial Cable for SDI	Coaxial Cable	IEEE1394b Cable	Camera LinkHS Cable
Max. Cable Length	100m	5m	3m	25m	150m	Approx. 5m to 12m		100m	5m	100m	100m	100m	15m
Image Transmission Capacity	☆☆	☆	☆☆☆	☆☆☆☆☆	☆☆☆☆☆	☆☆	☆☆☆☆	☆☆	☆☆	☆☆	☆	☆☆	☆☆
Max. Transmission Speed	122 fps 30 Megapixel - 15 fps 500 Megapixel (1,000Mbps)	90 fps 30 Megapixel - 15 fps 200 Megapixel (480Mbps)	123 fps 30 Megapixel - 14 fps 500 Megapixel (5,000Mbps)	25Gbps	12.5Gbps/40Gbps	240 fps 30 Megapixel - 16 fps 500 Megapixel (2,380Mbps)	600 fps 30 Megapixel - 60 fps 1200 Megapixel (7,140Mbps)	90 fps 30 Megapixel - 15 fps 200 Megapixel	60fps1080p	60fps1080p	59.94 fps 30 Megapixel (interlaced)	800Mbps	2,100Mbps
Power over Cable	○(PoE Model)	○(All Models)		○	Separate Power Supply	○(PoCL Model)		Separate Power Supply	Separate Power Supply	Separate Power Supply	Separate Power Supply	○	○
Software Provider	Camera Manufacturer	Camera Manufacturer		Board Manufacturer	Board Manufacturer	Board Manufacturer		Board Manufacturer	Not required			Camera Manufacturer	Board Manufacturer
System Cost	Low	Low		High	High	High		High	Low	Mid	Low	Low	High
Multiple Device Connection	Add Ethernet card or use switching hub	Add USB port expansion card (hub not recommended)		Add frame grabber board	Add frame grabber board	Add frame grabber board		Add frame grabber board	Use switcher			IEEE1394b expansion card, use hub	Add frame grabber board
Advantages	- Long cable length - Cheap cost to connect multiple cameras - Frame grabber not required	- Easy to connect - Low cost - Cheap cost to connect multiple cameras		- Long cable length - High transmission capacity	- Long cable length - Strong to noise	- Proven track record - High transmission capacity		- Proven track record - Long cable length	- Can easily be connected directly to monitor	- Long cable length	- Proven track record - Low cost - Long cable length	- Proven track record	- High transmission capacity - Smaller connector compared with Camera Link
Disadvantages	- Lower fps comparing with other interfaces	- Short cable length		- No extensive track record - High board cost	- No extensive track record - Few compatible board	- Short cable length - High board and cable cost - High cost to connect multiple cameras		- High board and cable cost	- Short cable length - No trigger function	- Few SDI-compatible monitors	- Low resolution	- Short cable length - IEEE1394b card required	- High board and cable cost
Main Applications	- Image processing - Monitoring	- Image processing - Monitoring		- Image processing - Monitoring	- Image processing - Monitoring	- Image processing		- Image processing	- Monitoring		- Image processing - Monitoring	- Image processing	- Image processing

\*System costs, advantages and disadvantages are subjective opinions by OMRON

# Camera Line-up Chart

The horizontal indicates pixels and the vertical indicates frame rates

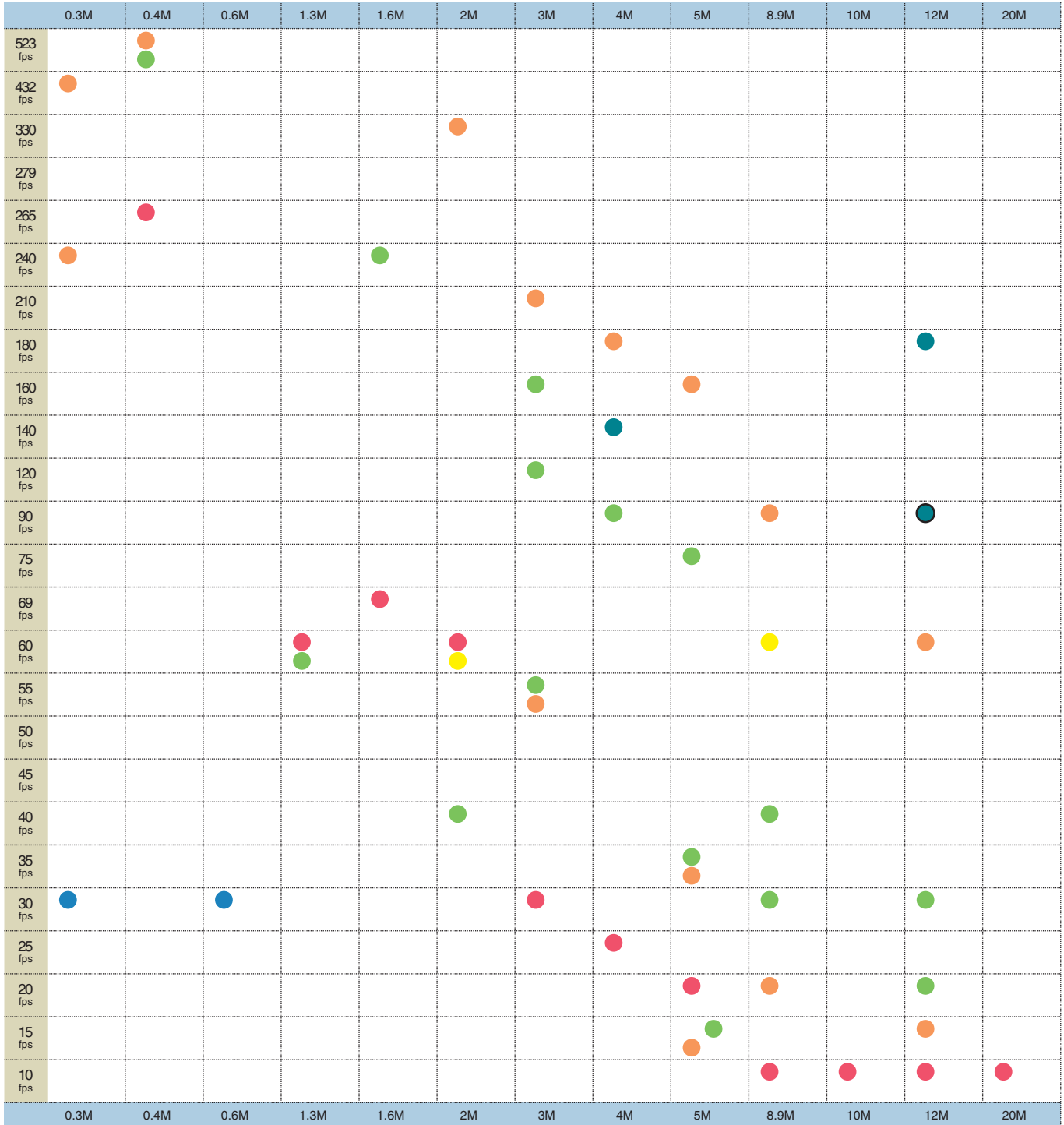

- GigE Vision
- USB3.0
- CameraLink
- CoaXPress
- OPT-C:Link
- HDMI/DVI/SDI
- TV Format

# GigE Vision Small CMOS Camera M Series



## Description

PoE-compatible GigE Vision camera with high-resolution, high-speed CMOS sensor

## Features

More compact body (29 x 29 mm) and new functionality

## Product Line-up

Model	Monochrome/Color	Resolution	Frame Rate	Effective Pixels (H x V)	Sensor Size	Cell Size (μm)	Sensor	Lens Mount	General Specifications
STC-MBS43POE	Monochrome	0.4M	265fps	728 × 544	1/2.9	6.9 × 6.9	IMX287	C	
STC-MCS43POE	Color								
STC-MBS163POE	Monochrome	1.6M	69fps	1456 × 1088	1/2.9	3.45 × 3.45	IMX273	C	
STC-MCS163POE	Color								
STC-MBS202POE	Monochrome	2M	54.6fps	1624 × 1440	1/1.7	4.5 × 4.5	IMX430	C	
STC-MCS202POE	Color								
STC-MBS312POE	Monochrome	3.2M	33.4fps	2048 × 1536	1/1.8	3.45 × 3.45	IMX265	C	
STC-MCS312POE	Color								
STC-MBS500POE	Monochrome	5M	21fps	2448 × 2048	2/3	3.45 × 3.45	IMX264	C	
STC-MCS500POE	Color								
STC-MBS1242POE	Monochrome	12M	8.7fps	4000 × 3000	1/1.7	1.85 × 1.85	IMX226	C	Rolling shutter
STC-MCS1242POE	Color								
STC-MBS2041POE	Monochrome	20M	5.6fps	5472 × 3648	1	2.4 × 2.4	IMX183	C	Rolling shutter
STC-MCS2041POE	Color								

Tripod		
Model	Applicable Model	General Specifications
TP-KWA	GigE Vision M Series	
TP-KWA-IEA	GigE Vision M Series	Used to set M Series with sensor center at same height as that of S Series

Note. Ask your Omron representative about AC adapter.

## External Connector Specification

External Link Connector

Ethernet: RJ45, power supply and I/O: HR10A-7R-6PB (Hirose) or equivalent

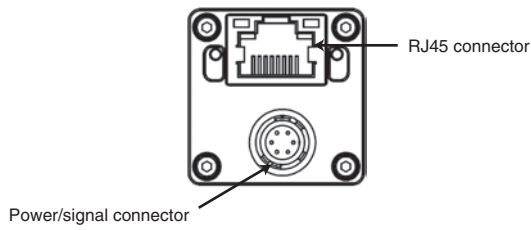

Pin Assignment

Pin No.	Signal name	I/O	Signal voltage
1	POWER IN	IN	10.8 to 26.4 Vdc
2	Isolated input (Line0)	IN	Low: 1.0 V or less High: 3.0 to 26.4 V * Potential difference between isolated input and isolated I/O common
3	Non-isolated I/O (Line2)	IN / OUT	3.0 to 26.4 V/Open Collector
4	Isolated output (Line1)	OUT	Open Collector
5	Isolated I/O common	IN	
6	GND	IN	0 V

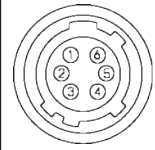

## Drawing dimension

Monochrome

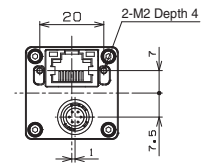
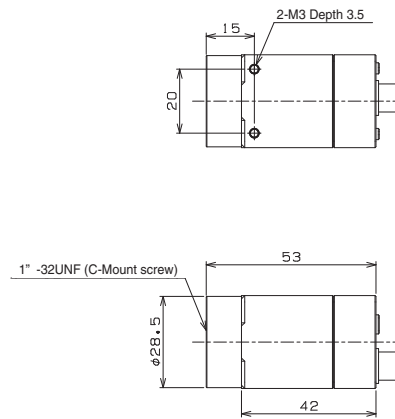
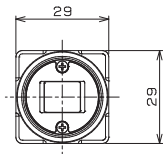
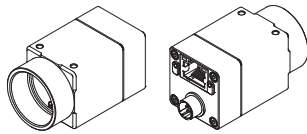

Color

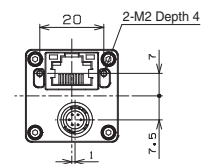
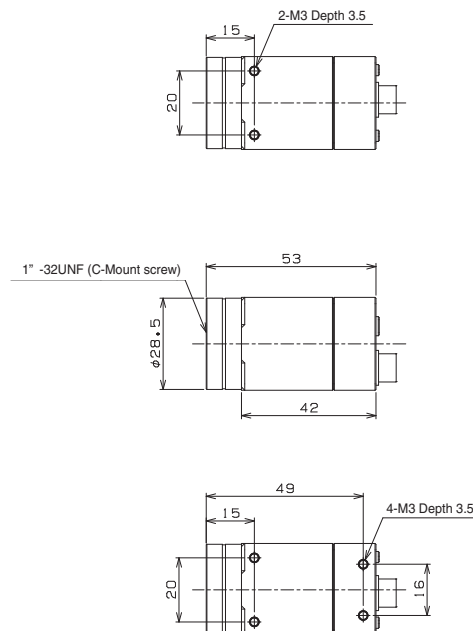
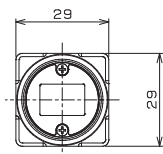
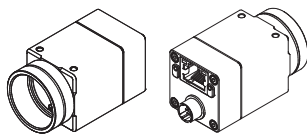

# GigE Vision Small CMOS Camera S Series



## Description

PoE-compatible GigE Vision camera with high-resolution, high-speed CMOS sensor

## Features

Sony CMOS [Pregius] adopted cameras are also available

## Product Line-up

Model	Monochrome/Color	Resolution	Frame Rate	Cell Size(HxV, $\mu\text{m}$ )	Sensor	Cell Size( $\mu\text{m}$ )	Sensor	Lens Mount	General Specifications
STC-SBS43POE	Monochrome	0.4M	265fps	728 × 544	1/2.9	6.9 × 6.9	IMX287	C	
STC-SCS43POE	Color								
STC-SBE132POE	Monochrome	1.3M	61fps	1280 × 1024	1/1.8	5.3 × 5.3	EV76C560	C	
STC-SCE132POE	Color								
STC-SBS163POE	Monochrome	1.6M	69fps	1456 × 1088	1/2.9	3.45 × 3.45	IMX273	C	
STC-SCS163POE	Color								
STC-CMB2MPOE	Monochrome	2M	50fps	2024 × 1088	2/3	5.5 × 5.5	CMV2000	C	
STC-CMC2MPOE	Color								
STC-CMB2MPOE-IR	NIR								
STC-SBS231POE	Monochrome	2.3M	41.6fps	1920 × 1200	1/1.2	5.86 × 5.86	IMX249	C	
STC-SCS231POE	Color								
STC-SBS312POE	Monochrome	3.2M	33.4fps	2048 × 1536	1/1.8	3.45 × 3.45	IMX265	C	
STC-SCS312POE	Color								
STC-CMB4MPOE	Monochrome	4M	25fps	2048 × 2048	1	5.5 × 5.5	CMV4000	C	
STC-CMC4MPOE	Color								
STC-CMB4MPOE-IR	NIR								
STC-SBS500POE	Monochrome	5M	21fps	2448 × 2048	2/3	3.45 × 3.45	IMX264	C	
STC-SCS500POE	Color								
STC-SBA503POE	Monochrome	5M	14fps	2592 × 1944	1/2.5	2.2 × 2.2	MT9P031	C	Rolling Shutter
STC-SCA503POE	Color								
STC-SCS853POE	Color	8M	12.7fps	3840 × 2160	1/2.5	1.62 × 1.62	IMX274	C	Rolling Shutter
STC-SBS1242POE	Monochrome	12M	8.7fps	4000 × 3000	1/1.7	1.85 × 1.85	IMX226	C	Rolling Shutter
STC-SCS1242POE	Color								

\* You are recommended to use the GigE Vision M Series because the S Series will be discontinued.

Note. Ask your Omron representative about AC adapter.

## External Connector Specification

External Connectors

Ethernet: RJ45, Power Supply I/O: HR10A-7R-6PB (Hirose)

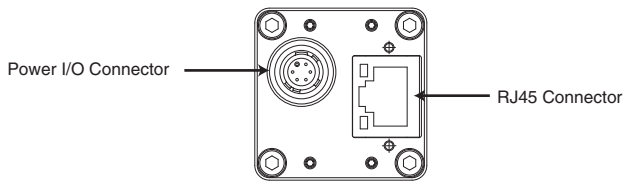

- ▶ HR10A-7R-6PB (Hirose) or equivalent
- ▶ This connector supplies both power (12V DC) and input / output signals
- ▶ Please use HR10A-7P -6S (Hirose) or equivalent for the cable

### Pin Assignments

Pin No.	Description	I/O	Signal Voltage
1	GND	IN	0V
2	Output1	OUT	Open Collector
3	Output2	OUT	Open Collector
4	TRG In- Opt.Isolated-	IN	Low: Smaller than +1.0V High: +3.0 to +26.4V
5	TRG In+ Opt.Isolated+	IN	*Potential difference between TRG_In- and TRG_In+
6	Power in	IN	+10.8 to 26.4 Vdc

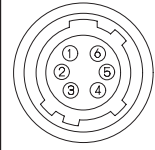

- ▶ Output 1 and Output 2 can be assigned by the communication (Device Code=00H, Command=F0H and F1H)

## Drawing dimension

Representative model: STC-SBS43POE

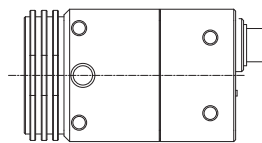
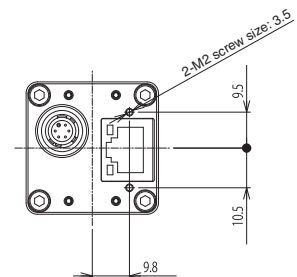
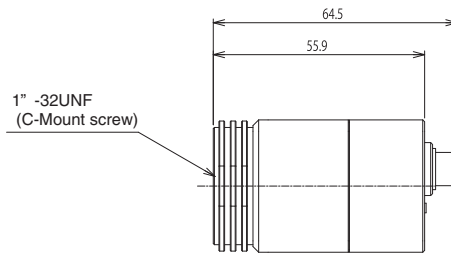
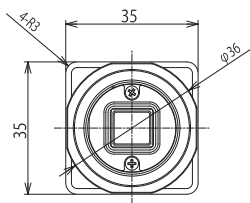
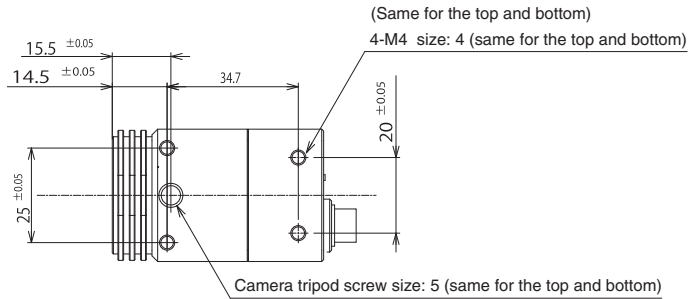
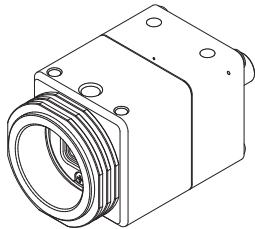

\* Drawings are differed by model. Please confirm the CAD data of each model.

# USB3.0 Series

USB



## Description

USB3.0 Compact CMOS Camera

## Features

Sony CMOS [Pregius] adopted cameras are lined up  
 High resolution-high speed CMOS sensors adopted  
 Compact, robust and easy to attach

## Product Line-up

Model	Monochrome/Color	Resolution	Frame Rate	Effective Pixels (H x V)	Sensor Size	Cell Size (μm)	Sensor	Lens Mount	General Specifications
STC-MBS43U3V	Monochrome	0.4M	523.5fps	720 × 540	1/2.9	6.9 × 6.9	IMX287	C	USB3Vision Available
STC-MCS43U3V	Color								
STC-MBE132U3V	Monochrome	1.3M	60fps	1280 × 1024	1/1.8	5.3 × 5.3	EV76C560	CS	USB3Vision Available
STC-MCE132U3V	Color								
STC-MBS163U3V	Monochrome	1.6M	236.3fps	1440 × 1080	1/2.9	3.45 × 3.45	IMX273	C	USB3Vision Available
STC-MCS163U3V	Color								
STC-MBCM200U3V	Monochrome	2M	167fps	2048 × 1088	2/3	5.5 × 5.5	CMV2000	C	USB3Vision Available
STC-MCCM200U3V	Color								
STC-MBCM200U3V-NIR	NIR								
STC-MBS231U3V	Monochrome	2.3M	41.7fps	1920 × 1200	1/1.2	5.86 × 5.86	IMX249	C	USB3Vision Available
STC-MCS231U3V	Color								
STC-MBS241U3V	Monochrome	2.3M	163fps	1920 × 1200	1/1.2	5.86 × 5.86	IMX174	C	USB3Vision Available
STC-MCS241U3V	Color								
STC-MBS312U3V	Monochrome	3.2M	55.6fps	2048 × 1536	1/1.8	3.45 × 3.45	IMX265	C	USB3Vision Available
STC-MCS312U3V	Color								
STC-MBS322U3V	Monochrome	3.2M	121fps	2048 × 1536	1/1.8	3.45 × 3.45	IMX252	C	USB3Vision Available
STC-MCS322U3V	Color								
STC-MBCM401U3V	Monochrome	4M	89fps	2048 × 2048	1	5.5 × 5.5	CMV4000	C	USB3Vision Available
STC-MCCM401U3V	Color								
STC-MBCM401U3V-NIR	NIR								
STC-MBA5MUSB3	Monochrome	5M	14fps	2592 × 1944	1/2.5	2.2 × 2.2	MT9P031	CS	Rolling Shutter
STC-MCA5MUSB3	Color								
STC-MBS500U3V	Monochrome	5M	35.7fps	2448 × 2048	2/3	3.45 × 3.45	IMX264	C	USB3Vision Available
STC-MCS500U3V	Color								
STC-MBS510U3V	Monochrome	5M	75.7fps	2448 × 2048	2/3	3.45 × 3.45	IMX250	C	USB3Vision Available
STC-MCS510U3V	Color								
STC-MBS881U3V	Monochrome	8.9M	32.2fps	4096 × 2160	1	3.45 × 3.45	IMX267	C	USB3Vision Available
STC-MCS881U3V	Color								
STC-MBS891U3V	Monochrome	8.9M	42.3fps	4096 × 2160	1	3.45 × 3.45	IMX255	C	USB3Vision Available
STC-MCS891U3V	Color								
STC-MBS122BU3V	Monochrome	12.3M	23.4fps	4096 × 3000	1.1	3.45 × 3.45	IMX304	C	USB3Vision Available
STC-MCS122BU3V	Color								
STC-MBS123BU3V	Monochrome	12.3M	30.5fps	4096 × 3000	1.1	3.45 × 3.45	IMX253	C	USB3Vision Available
STC-MCS123BU3V	Color								

\* 8.9M, 12M cameras may not have sufficient supply power with USB bus supply only depending on PC spec. We recommend you to use external power.

## Accessories

### Screw Lock USB3.0 Cables

Model	Applicable Model	Specification
NU3MBASU3S-2m	All USB3.0 Cameras	2m,USB3.0 MicroB,wish camera-side fastening screws,normal cables
NU3MBASU3S-3.5m	All USB3.0 Cameras	3.5m,USB3.0 MicroB,wish camera-side fastening screws,normal cables
NU3MBASU3B-2m	All USB3.0 Cameras	2m,USB3.0 MicroB,wish camera-side fastening screws,robot cables
NU3MBASU3B-3.5m	All USB3.0 Cameras	3.5m,USB3.0 MicroB,wish camera-side fastening screws,robot cables

\*Please make sure that USB 3.0 cables operate correctly under your environment beforehand

### Mount Conversion Adapter

Model	Applicable Model	Specification
CS-C-R	CS Mount Series	

### Tripod Mount

Model	Relevant Cameras	Specification
TP-HCA*	STC-MCE/MBE132U3V, STC-MCA/MBAS5MUSB3	
TP-JVA	Except for STC-MCE/MBE132U3V, STC-MBA/MCAS5MUSB3	

\* The tripod mount is screwed at two points on the lens side.

## External Connector Specification

External Connector	USB: USB3.0 MicroB type, I/O signals: HR10A-7R-6PB(Hirose) or equivalent
--------------------	--

- ▶ This connector is for the output signal, not for the power of the camera. The camera power is supplied in +5V from the USB cable  
It does not affect the voltage for the input signal

### Pin Assignment

Pin No.	Signal Name	I/O	Signal Voltage	
			Low	High
1	GND for I/O signal	-	0V	
2	Output 2(IO3)	OUT	0.8V or lower	+3 - +26.4 V
3	Output 1(IO2)	OUT	0.8V or lower	+3 - +26.4 V
4	Input 2(IO1)	IN	0.7V or lower	+1.7 - +5 V
5	Input 1(IO0)	IN	0.7V or lower	+1.7 - +5 V
6	Power supply for output signal (IO_VCC)	-	+3 to +26.4Vdc	

\*Example shown for reference

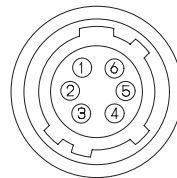

[Rear view]

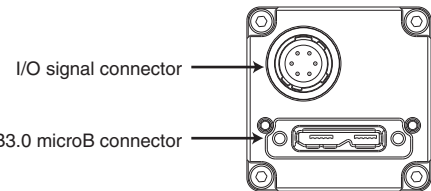

I/O signal connector

USB3.0 microB connector

\*Please use HR10A-7P-6S (Hirose) or equivalent for the cable

## Drawing dimension

STC-MBE/MCE132U3V  
STC-MBA/MCA5MUSB3

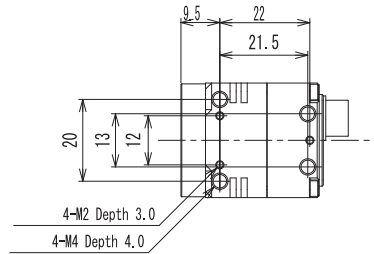
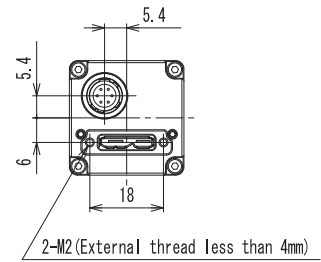
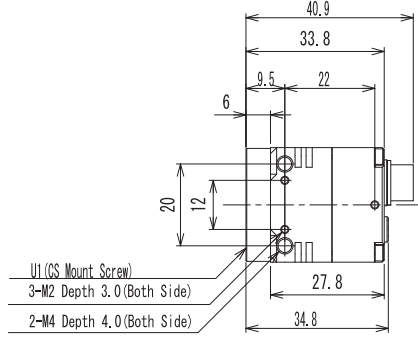
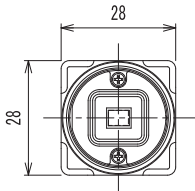
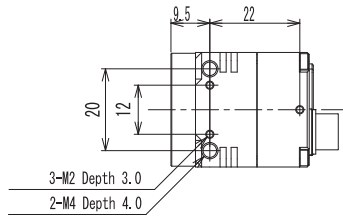

STC-MBS/MCS43U3V  
STC-MBS/MCS163U3V  
STC-MBCM/MCCM200U3V(-NIR)  
STC-MBCM/MCCM401U3V(-NIR)  
STC-MBS/MCS241U3V  
STC-MBS/MCS231U3V  
STC-MBS/MCS312U3V  
STC-MBS/MCS322U3V  
STC-MBS/MCS500U3V  
STC-MBS/MCS510U3V

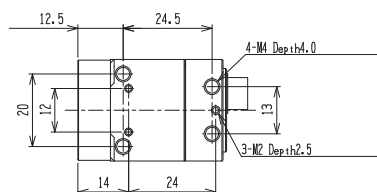
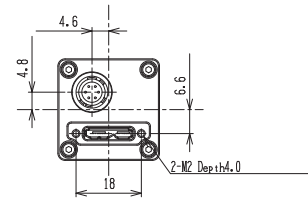
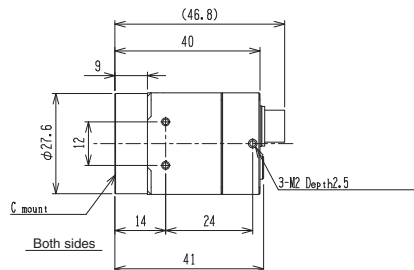
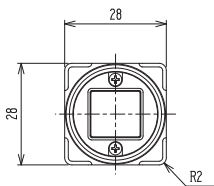
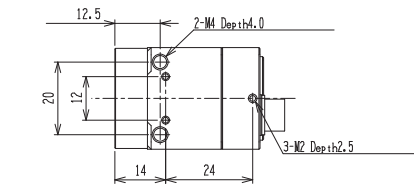

STC-MBS/MCS881U3V  
 STC-MBS/MCS891U3V  
 STC-MBS/MCS122BU3V  
 STC-MBS/MCS123BU3V

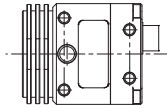
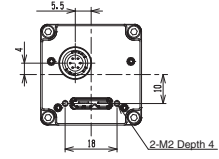
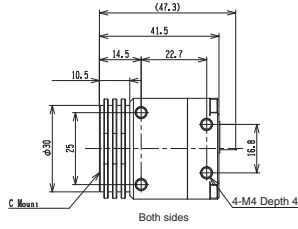
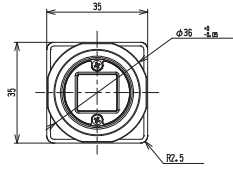
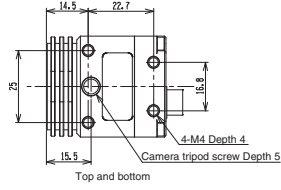
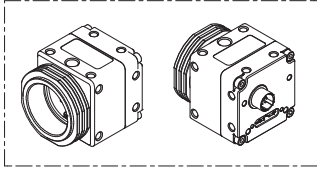

USB

# USB3.0 Remote Head Camera

USB



## Description

Ultra-compact USB3 Vision remote head camera

## Features

Separate sensor head for installation in previously difficult locations. Robust cable ideal for moving parts

## Product Line-up

Available soon

Model	Monochrome/Color	Resolution	Frame Rate	Effective Pixels (H x V)	Sensor Size	Cell Size (μm)	Sensor	Lens Mount	General Specifications
STC-RBS163U3V-SM121	Monochrome	1.6M	238fps	1440 × 1080	1/2.9	3.45 × 3.45	IMX273	S	USB3 Vision compliant Cable from rear, cable length: 1 m
STC-RCS163U3V-SM121	Color	1.6M	238fps	1440 × 1080	1/2.9	3.45 × 3.45	IMX273	S	USB3 Vision compliant Cable from rear, cable length: 1 m
STC-RBS163U3V-SM12	Monochrome	1.6M	238fps	1440 × 1080	1/2.9	3.45 × 3.45	IMX273	S	USB3 Vision compliant Cable from rear, cable length: 2.5 m
STC-RCS163U3V-SM12	Color	1.6M	238fps	1440 × 1080	1/2.9	3.45 × 3.45	IMX273	S	USB3 Vision compliant Cable from rear, cable length: 2.5 m

## External Connector Specification

External Link Connector	HR10A-7R-6PB (Hirose) or equivalent
-------------------------	-------------------------------------

Connector for I/O signals.  
Use HR10A-7P-6S (Hirose) or equivalent for the cable.

### Pin Assignment

Pin No.	Signal name	I/O
1	IO_GND	-
2	GPIO2	IN/OUT
3	GPIO1	IN/OUT
4	GPIO0	IN/OUT
5	CAM_RESET	IN
6	N.C.	-



\* The maximum rated voltage to CAM\_RESET, GPIO0, GPIO1, and GPIO2 is 24 V.  
\* Leave the N.C. pin open.





## Description

High Speed CMOS CoaXPress Camera

## Features

- 4M, 12M
- High speed (186fps at 12M pixel)
- Light angle type also available

## Product Line-up

Model	Monochrome/Color	Resolution	Frame Rate	Effective Pixels (H x V)	Sensor Size	Cell Size (µm)	Sensor	Lens Mount	General Specifications
STC-CMB401CXP	Monochrome	4M	142.5fps	2048 × 2048	1	5.5 × 5.5	CMV4000	C	PoCXP Copatibility, 1Lane
STC-CMC401CXP	Color								
STC-CMB120ACXP	Monochrome	12M	186fps	4096 × 3072	1.76	5.5 × 5.5	CMV12000	M42 P=1 FB10 mm	PoCXP Copatibility, 4Lane, Connector from rear
STC-CMC120ACXP	Color								
STC-CMB120ACXP-T	Monochrome	12M	186fps	4096 × 3072	1.76	5.5 × 5.5	CMV12000	M42 P=1 FB10 mm	PoCXP Copatibility, 4Lane, Connector from Upperside
STC-CMC120ACXP-T	Color								
STC-CMB120ACXP-F	Monochrome	12M	186fps	4096 × 3072	1.76	5.5 × 5.5	CMV12000	F	PoCXP Copatibility, 4Lane, Connector from rear
STC-CMC120ACXP-F	Color								
STC-CMB120ACXP-T-F	Monochrome	12M	186fps	4096 × 3072	1.76	5.5 × 5.5	CMV12000	F	PoCXP Copatibility, 4Lane, Connector from upperside
STC-CMC120ACXP-T-F	Color								

## Accessories

Mount Conversion Adapter		
Model	Supported Models	General Specifications
M42-F-R	12M Model	M42 P=1 FB=10mm → Fmount Conversion Adapter



# Opt-C:Link

CameraLink  
Over



## Description

High Speed Opt-C: Link

## Features

High FPS (93.4FPS at 12M pixel) achieved  
Cable extension, noise resistance by using optical cable

## Product Line-up

Model	Monochrome/Color	Resolution	Frame Rate	Effective Pixels (H x V)	Sensor Size	Cell Size (μm)	Sensor	Lens Mount	General Specifications
STC-CMB120AOPT-F	Monochrome	12M	93.4fps	4096 × 3072	1.76	5.5 × 5.5	CMV12000	F	External power supply, SFP+optical connectorx2
STC-CMC120AOPT-F	Color								

## Accessories

Mount Conversion Adapter		
Model	Applicable Model	General Specifications
M42-F-R	12M	M42 P=1 FB=10mm → Fmount Conversion Adapter

Note. Ask your Omron representative about AC adapter.

## External Connector Specification

STC-CMB/CMC120AOPT  
External Connector Specification

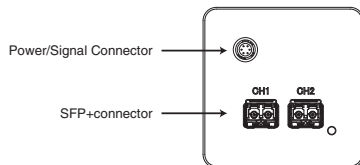

SFP+connector  
57D9AMZ (AVAGO) or equivalentx2

- Channel : 2CH
- Transmission Rate : 6.25Gbps
- Transmission Mode : MultiMode
- Laser Format : 850nmVCSEL
- Laser Safety Standard : Class 1
- Connector Type : LC connector
- Cable Spec : CoreØ 50μm/62.5μm, CladØ 125μm,

Please supply power (12Vdc) from the power-I/O connector  
Please use CH1, CH2 connector with connecting cables

2 Power/Signal Connector  
HR10A-7R-6PB (Hirose) or equivalent  
Connector for power (12Vdc) , Trigger signal  
Trigger signal can be generated by camera setting  
Please use an HR10A-7P-6S (Hirose) equivalent for the cable

### Pin Assignment

PIN No.	Signal Name	IN/OUT	Signal Voltage	
			LOW Voltage	HIGH Voltage
1	GND	IN		
2	SP4	IN/OUT	IN 0 ~ +0.99V	+2.3 ~ +3.6V
			OUT 0V	+3.3V
3	SP3	IN/OUT	IN 0 ~ +0.99V	+2.3 ~ +3.6V
			OUT 0V	+3.3V
4	SP2	IN/OUT	IN 0 ~ +0.99V	+2.3 ~ +3.6V
			OUT 0V	+3.3V
5	SP1	IN/OUT	IN 0 ~ +0.99V	+2.3 ~ +3.6V
			OUT 0V	+3.3V
6	+12Vdc	IN	+12Vdc	



Trigger input signal can be assigned either on Opt-Clink trigger packet (CC1) or on the No. 2 pin of the power/I/O connector through the camera setting communication.

# Drawing dimension

STC-CMB/CMC120AOPT

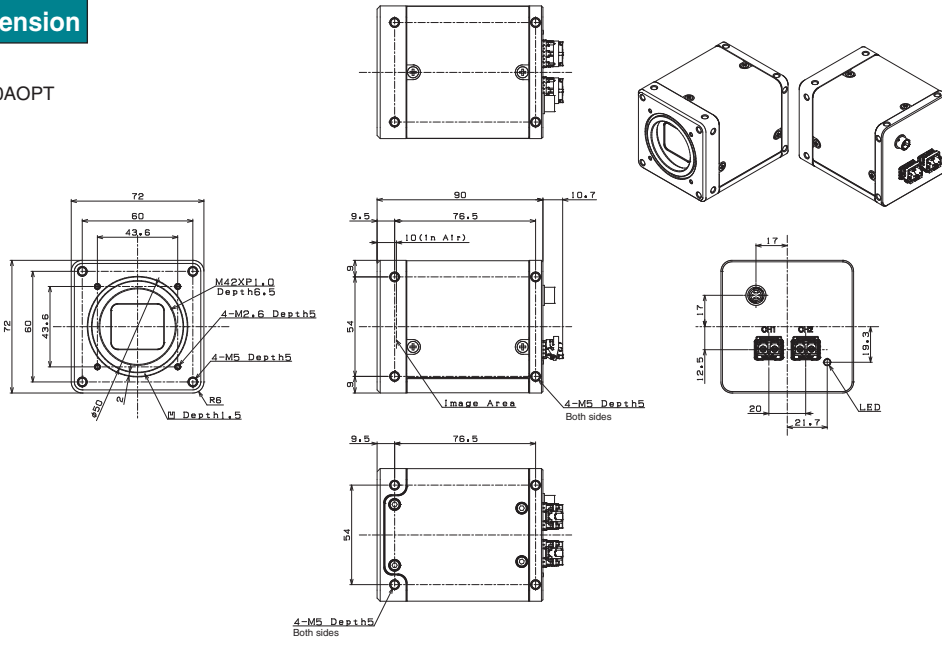

# CameraLink CMOS



## Description

High Speed CMOS Camera Link Series

## Features

Sony CMOS [Pregius] are also available

High resolution and high FPS implemented simultaneously by high performance CMOS sensor

## Product Line-up

Model	Monochrome/Color	Resolution	Frame Rate	Effective Pixels (H x V)	Sensor Size	Cell Size (µm)	Sensor	Lens Mount	General Specifications
STC-CMB33PCL	Monochrome	VGA	432fps	642 × 484	1/3	7.4 × 7.4	CMV300	C	PoCL,automatically switched, SDR connectorx2
STC-CMC33PCL	Color								
STC-SPB43PCL	Monochrome	0.4M	523.5fps	720 × 540	1/2.9	6.9 × 6.9	IMX287	C	PoCL,automatically switched, SDR connectorx1
STC-SPC43PCL	Color								
STC-SPB163PCL	Monochrome	1.6M	155fps	1440 × 1080	1/2.9	3.45 × 3.45	IMX273	C	PoCL,automatically switched, SDR connectorx1
STC-SPC163PCL	Color								
STC-CMB200PCL	Monochrome	2M	333fps	2048 × 1088	2/3	5.5 × 5.5	CMV2000	C	PoCL,automatically switched, SDR connectorx2
STC-CMC200PCL	Color								
STC-CMB200PCL-NIR	NIR								
STC-SPB312PCL	Monochrome	3.2M	57.1fps	2048 × 1536	1/1.8	3.45 × 3.45	IMX265	C	PoCL,automatically switched, SDR connectorx1
STC-SPC312PCL	Color								
STC-SPB322PCL	Monochrome	3.2M	216.2fps	2048 × 1536	1/1.8	3.45 × 3.45	IMX252	C	PoCL,automatically switched, SDR connectorx2
STC-SPC322PCL	Color								
STC-CMB401PCL	Monochrome	4M	180fps	2048 × 2048	1	5.5 × 5.5	CMV4000	C	PoCL,automatically switched, SDR connectorx2
STC-CMC401PCL	Color								
STC-CMB401PCL-NIR	NIR								
STC-APB503PCL	Monochrome	5M	14fps	2592 × 1944	1/2.5	2.2 × 2.2	MT9P031	C	PoCL,automatically switched, SDR connectorx1
STC-APC503PCL	Color								
STC-SPB500PCL	Monochrome	5M	35.7fps	2448 × 2048	2/3	3.45 × 3.45	IMX264	C	PoCL,automatically switched, SDR connectorx1
STC-SPC500PCL	Color								
STC-SPB510PCL	Monochrome	5M	163.4fps	2448 × 2048	2/3	3.45 × 3.45	IMX250	C	PoCL,automatically switched, SDR connectorx2
STC-SPC510PCL	Color								
STC-SPB881PCL	Monochrome	8.9M	20.6fps	4096 × 2160	1	3.45 × 3.45	IMX267	C	PoCL,automatically switched, SDR connectorx1
STC-SPC881PCL	Color								
STC-SPB891PCL	Monochrome	8.9M	91.3fps	4096 × 2160	1	3.45 × 3.45	IMX255	C	PoCL,automatically switched, SDR connectorx2
STC-SPC891PCL	Color								
STC-SPB122BPCL	Monochrome	12M	15fps	4096 × 3000	1.1	3.45 × 3.45	IMX304	C	PoCL,automatically switched, SDR connectorx1
STC-SPC122BPCL	Color								
STC-SPB123BPCL	Monochrome	12M	66.9fps	4096 × 3000	1.1	3.45 × 3.45	IMX253	C	PoCL,automatically switched, SDR connectorx2
STC-SPC123BPCL	Color								
STC-CMB120APCL	Monochrome	12M	62.3fps	4096 × 3072	1.76	5.5 × 5.5	CMV12000	M42	PoCL,automatically switched, SDR connectorx2
STC-CMC120APCL	Color								
STC-CMB120APCL-F	Monochrome	12M	62.3fps	4096 × 3072	1.76	5.5 × 5.5	CMV12000	F	PoCL,automatically switched, SDR connectorx2
STC-CMC120APCL-F	Color								

## Accessories

### Mount Conversion Adapter

Model	Applicable Model	General Specifications
M42-F-R	12M	M42 P=1 FB=10mm → Fmount Conversion Adapter

Note. Ask your Omron representative about AC adapter.

## External Connector Specification

External Link Connectors	Camera Link connector: miniature connector (SDR) x 1, power supply I/O: HR10A-7R-6PB (Hirose) or equivalent
--------------------------	---

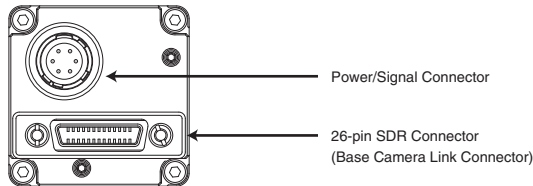

When used with the base configuration, connect the Camera Link cable to the Base connector for use.

PoCL Available

\*When used with Medium/Full/10tab configuration, please see the specification for applicable model

### Pin Assignment

#### Base Camera Link Connector

Pin No.	Signal Name	Pin No.	Signal Name
1	+12V	14	GND
2	X0-	15	X0+
3	X1-	16	X1+
4	X2-	17	X2+
5	Xclk-	18	Xclk+
6	X3-	19	X3+
7	SerTC+	20	SerTC-
8	SerTFG-	21	SerTFG+
9	CC1- (TRG)	22	CC1+ (TRG)
10	CC2+	23	CC2-
11	CC3-	24	CC3+
12	CC4+	25	CC4-
13	GND	26	+12V

### Pin Assignment

Pin No.	Signal Name	IN/OUT	Signal Voltage		
			Low Voltage	High Voltage	
1	GND	IN	0 V		
2	SP-4	IN/OUT	IN	0 to 0.99 V	2.3 to 5.0 V
			OUT	0 V	3.3 V
3	SP-3	IN/OUT	IN	0 to 0.99 V	2.3 to 5.0 V
			OUT	0 V	3.3 V
4	SP-2	IN/OUT	IN	0 to 0.99 V	2.3 to 5.0 V
			OUT	0 V	3.3 V
5	SP-1	IN/OUT	IN	0 to 0.99 V	2.3 to 5.0 V
			OUT	0 V	3.3 V
6	+12Vdc	IN	12 Vdc		

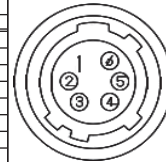

The trigger signal can be input from either one of the connectors listed below by the setting of the camera using communication Camera Link connector (CC1) or power supply/I/O connector (No. 2)

\*Please use HR10A-7P-6S (Hirose) or equivalent for the cable

# Drawing dimension

STC-CMB/CMC33PCL

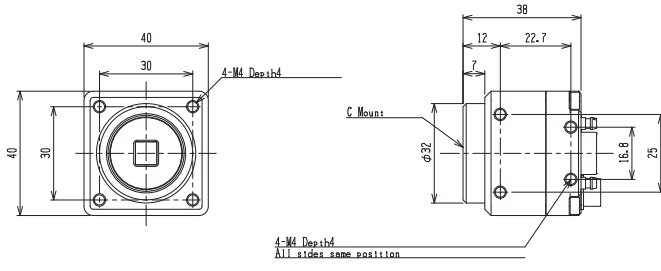

STC-CMB/CMC200PCL  
STC-CMB/CMC401PCL

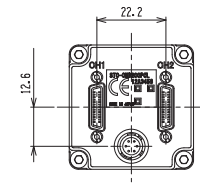
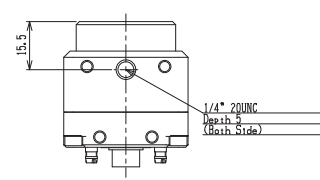
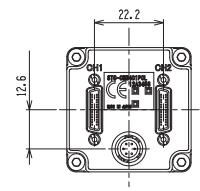
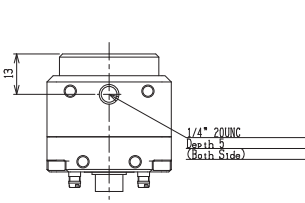
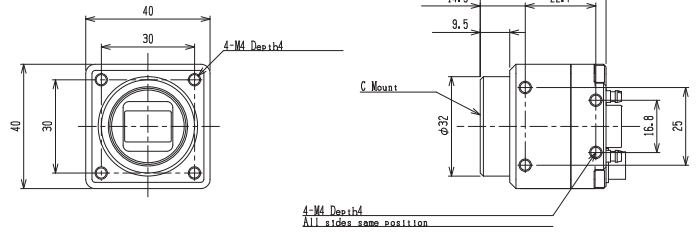

STC-APB/APC503PCL

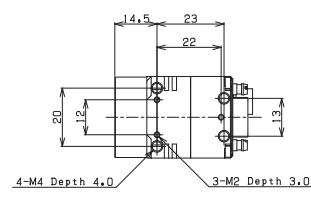
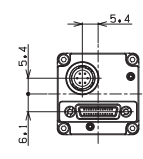
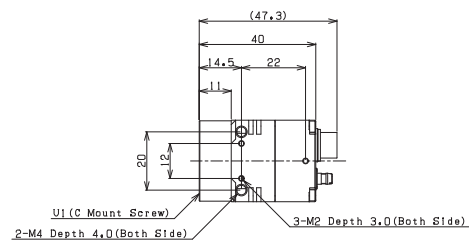
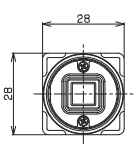
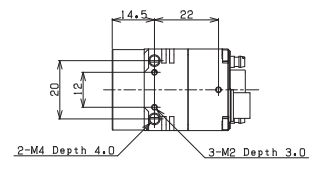

STC-SPB/SPC43PCL  
STC-SPB/SPC163PCL

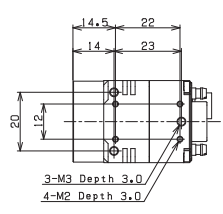
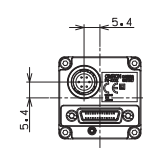
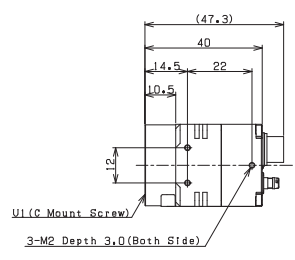
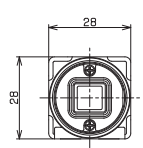
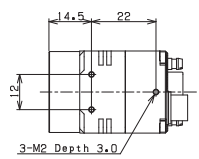

## Drawing dimension

STC-SPB/SPC322PCL  
 STC-SPB/SPC510PCL  
 STC-SPB/SPC891PCL  
 STC-SPB/SPC123BPCL

STC-SPB/SPC312PCL  
 STC-SPB/SPC500PCL  
 STC-SPB/SPC881PCL  
 STC-SPB/SPC122BPCL

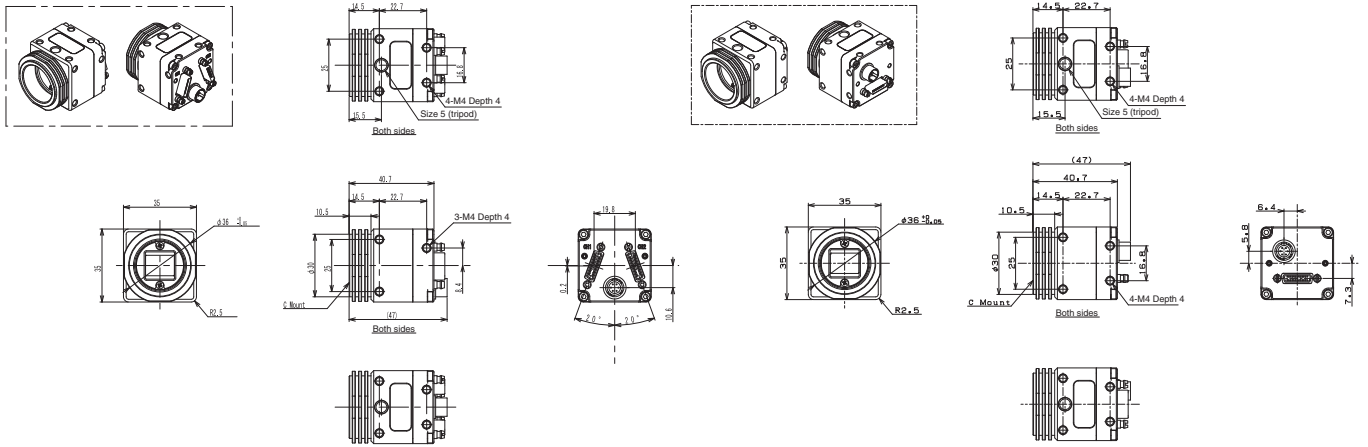

STC-CMB/CMC120APCL

STC-CMB/CMC120APCL-F

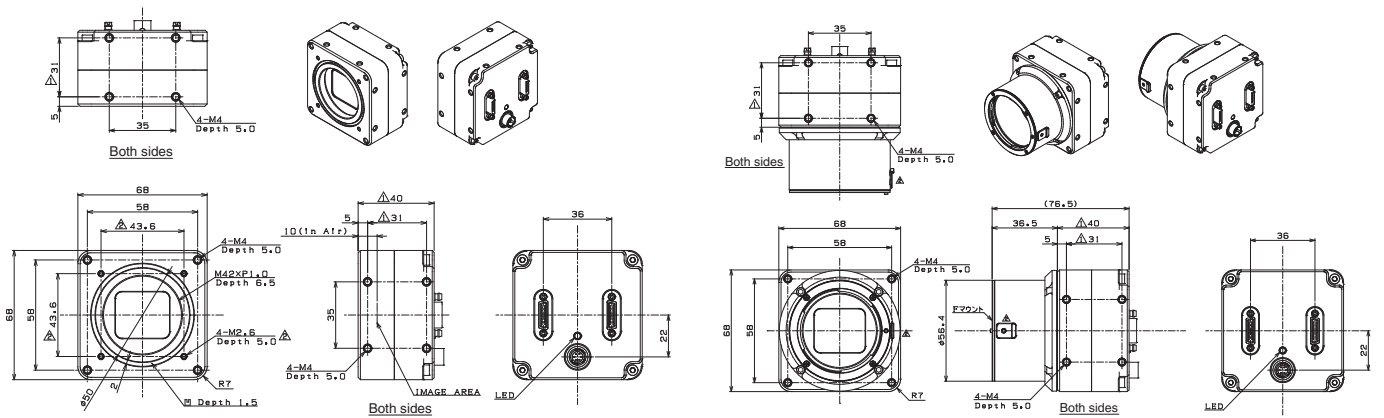

# 4K HDMI Camera



## Description

HDMI Output 4K Color Camera

## Features

HD Output 4K 60fps camera

Available 120fps output (1080p) at Full HD mode

\*Monitor screen must support the resolutions

Connectable to the monitor directly using HDMI connector

Optimized for observing system which cannot use PC

## Product Line-up

Model	Monochrome/Color	Resolution	Frame Rate	Effective Pixels (H x V)	Sensor Size	Cell Size (μm)	Sensor	Lens Mount
STC-HD853HDMI	Color	4K 2160P	60fps	3840 × 2160	1/2.5	1.62 × 1.62	IMX274	C

## Accessories

Remote Control Unit		
Model	Applicable Model	General Specifications
RC-HD133	All DVI/SDI models	ø3.5 stereo pin jack

Note. Ask your Omron representative about AC adapter.

HDMI/DVI/SDI

## External Connector Specification

External Link Connectors

HDMI connector: HDMI 2.0 compliant, power supply: MP121 equivalent, communications: ø3.5 stereo pin jack

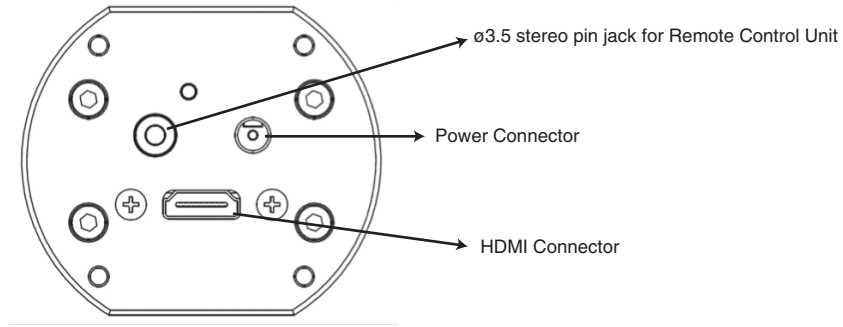

## Drawing dimension

STC-HD853HDMI

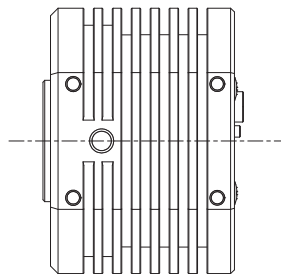
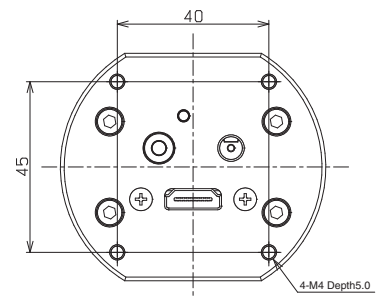
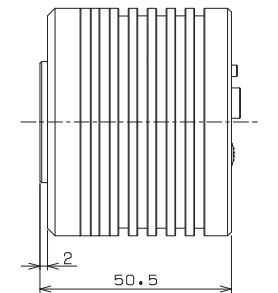
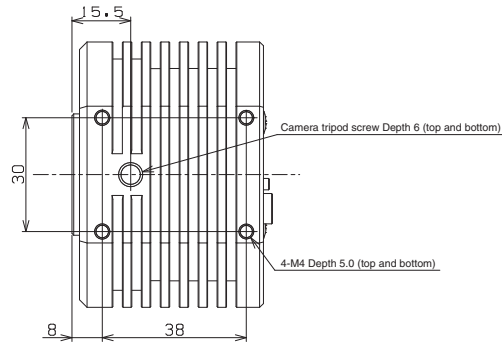
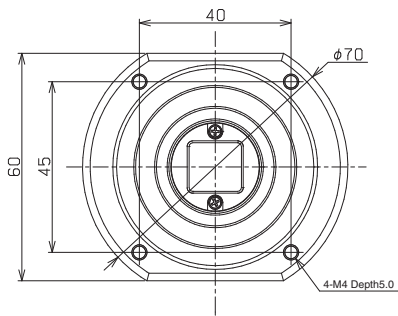
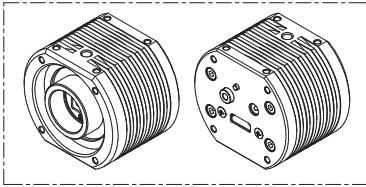

# HD High-Definition Camera



## Description

DVI Output Color Camera

## Features

Connect directly to monitor with HDMI connector to build observing system without PC. Use of optional remote unit enables crosshair and shadow masks to be displayed on screen.

## Product Line-up

Model	Monochrome/Color	Resolution	Frame Rate	Effective Pixels (H x V)	Sensor Size	Cell Size (μm)	Sensor	Lens Mount	General Specifications
STC-HD203DV	Color	HD 1080P	60fps	1920 × 1080	1/2.8	2.8 × 2.8	IMX136	C	Case
STC-HD203DV-CS	Color	HD 1080P	60fps	1920 × 1080	1/2.8	2.8 × 2.8	IMX136	CS	Case

## Accessories

CS-to-C-Mount Conversion Adapter		
Model	Applicable Model	General Specification
CS-C-R	CS Mount Camera	

Remote Control Unit		
Model	Applicable Model	General Specification
RC-HD133	All DVI/SDI Camera	ø3.5 stereo pin jack

Note. Ask your Omron representative about AC adapter.

## External Connector Specification

External Link Connectors

HDMI connector: DVI 1.0 compliant, power supply: MP-121C (Marushin Musen Denki) equivalent, communications: ø3.5 stereo pin jack

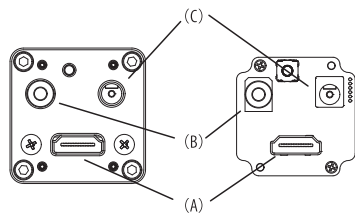

(A) HDMI connector  
The output is DVI 1.0 compliant.

(B) ø3.2 stereo pin jack for remote switch  
The connector for the configuration of various camera functions.

(C) Power supply connector  
Connector for DC12V AC adapter  
Compatible plug  
Marushin Musen Denki MP-121 equivalent

## External View

STC-HD203DV

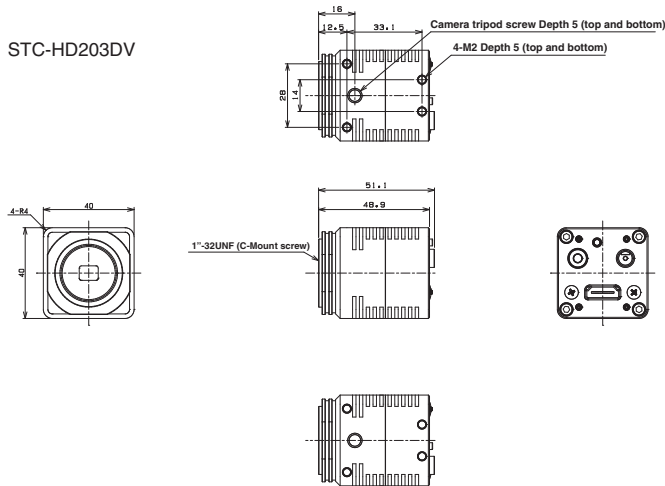

STC-HD203DV-CS

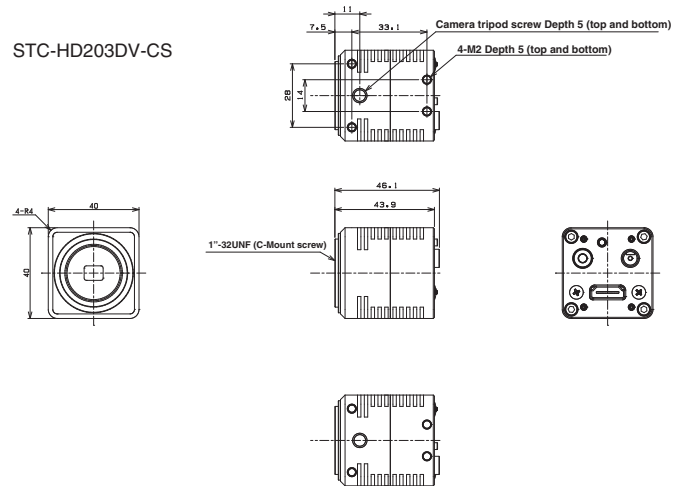

# HD-SDI HD Camera



## Description

HD-SDI Output Color Camera

## Features

Connect directly to monitor with versatile BNC connector. Suitable for long distance image transmission. Use of optional remote unit enables crosshair and shadow masks to be displayed on screen.

## Product Line-up

Model	Monochrome/Color	Resolution	Frame Rate	Effective Pixels (H x V)	Sensor Size	Cell Size (µm)	Sensor	Lens Mount	General Specifications
STC-HD203SDI	Color	HD 1080P	60fps	1920 × 1080	1/2.8	2.8 × 2.8	IMX136	C	Case
STC-HD203SDI-CS	Color	HD 1080P	60fps	1920 × 1080	1/2.8	2.8 × 2.8	IMX136	CS	Case

## Accessories

### Mount Conversion Adapter

Model	Applicable Model	General Specifications
CS-C-R	CS-Mount Model	

### Remote Control Unit

Model	Applicable Model	General Specifications
RC-HD133	All DVI/SDI Camera	ø3.5 stereo pin jack

Note. Ask your Omron representative about AC adapter.

## External Connector Specification

External Link Connectors

BNC connector: for HD-SDI, power supply: MP-121C (Marushin Musen Denki) or equivalent, communications: ø3.5 stereo pin jack

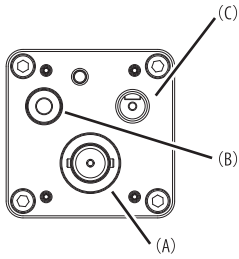

(A) BNC connector (Female)

The output is SMPTE292M compliant

(B) ø3.5 stereo pin jack for remote  
switch the connector for the configuration of  
various camera functions.

(C) Power supply connector

Compatible plug  
Marushin Musen Denki MP-121 equivalent

## Drawing dimension

STC-HD203SDI

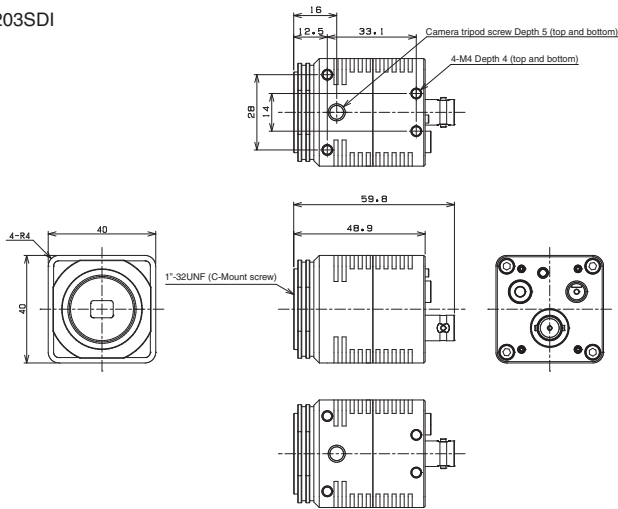

STC-HD203SDI-CS

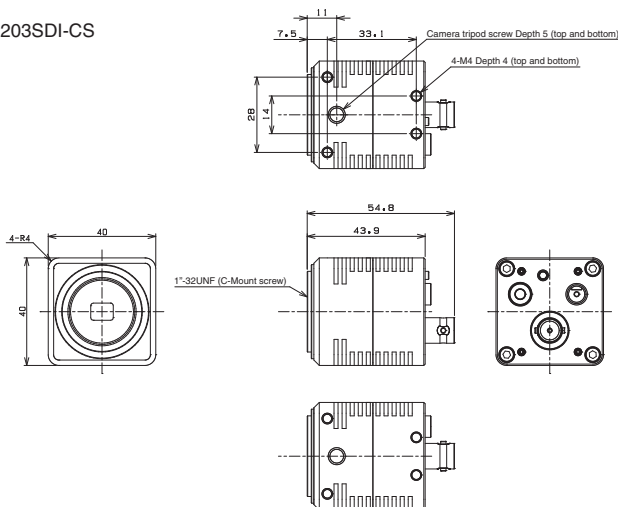

## Analog Progressive Camera Series



### Description

Smallest and lightest  
Progressive Scan Black and White CCD Camera

### Features

Lineup includes resolutions from VGA (0.33 mega pixels) to UXGA (2.0 mega pixels)

### Product Line-up

Model	Monochrome/Color	Resolution	Frame Rate	Cell Size (HxV, $\mu\text{m}$ )	Sensor Size	Cell Size ( $\mu\text{m}$ )	Sensor	Lens Mount
STC-MB33SS	Monochrome	VGA	90fps	648 x 494	1/3	7.4 x 7.4	RJ33B4AA0DT	C

## External Connector Specification

External Link Connectors

12 pin Connector: HR10A-10R-12PB (Hirose) or equivalent

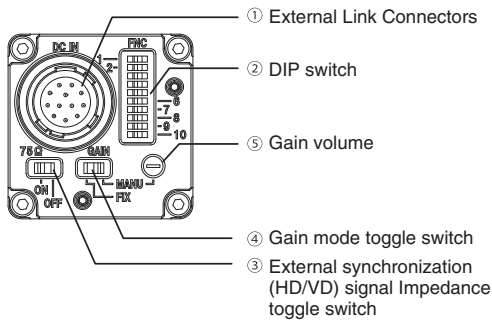

① External Link Connectors  
HR10A-10R-12PB (Hirose)  
equivalent



-RS-232C communications can also be performed using 9 pins or 12 pins  
-Functions that can be changed with a DIP switch can also be changed through communications  
See the user guide for details

Pin No.	Name	
	Internal Synchronization	External Synchronization
	GND	GND
2	+12V DC	+12V DC
3	VIDEO GND	VIDEO GND
4	VIDEO OUT	VIDEO OUT
5	HD GND	HD GND
6	HD OUT	HD IN
7	VD OUT	VD IN
8	GND	GND
9	TXD	TXD
10	WEN OUT	WEN OUT
11	TRG IN	TRG IN
12	RXD *Note1	RXD *Note1

Note 1: GND Connection possible

\* Please use an HR10A-10P-12S (Hirose) equivalent on the cable-side.

② DIP Switch

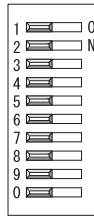

No. 1 to 3: Shutter Speed

Shutter Speed	No. 1	No. 2	No. 3
OFF/Pulse width	OFF	OFF	OFF
1/200 seconds	ON	OFF	OFF
1/500 seconds	OFF	ON	OFF
1/1,000 seconds	ON	ON	OFF
1/2,000 seconds	OFF	OFF	ON
1/4,000 seconds	ON	OFF	ON
1/8,000 seconds	OFF	ON	ON
1/20,000 seconds	ON	ON	ON

No.4 to 5: Reset Mode

Reset Mode	No. 4	No. 5
Non-Reset	OFF	OFF
V-Reset	ON	OFF
Function disabled	OFF	ON
Function disabled	ON	ON

No.6: Trigger Signal Polarity

Trigger Signal Polarity	No. 6
Positive Polarity	OFF
Negative Polarity	ON

No. 7 to 8: Scan Mode

Scan Mode	No. 7	No. 8
Full Scan	OFF	OFF
Full Scan	ON	OFF
1/2 Partial	OFF	ON
1/4 Partial	ON	ON

No.9: Input/output of

Synchronization Signal

Input/output of Synchronization Signal	No. 9
Input	OFF
Output	ON

No. 0: Binning Mode

Binning Mode	No. 10
OFF	OFF
ON	ON

③ External Synchronization (HD/VD)  
Signal Impedance Selection Switch

75 Ω Termination	ON
High Impedance	OFF

④ Gain Mode Toggle Switch

Fixed Gain (internal camera setting)	FIX
Manual Gain	MANU

## Drawing dimension

STC-MB33SS

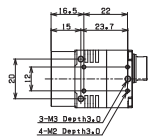
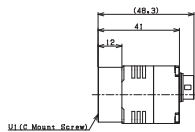
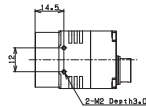
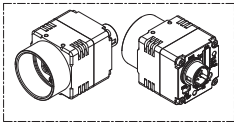

# TV Format Color Camera S133N-B Series



## Description

1/3.2" 0.65 Mpix TV format color CMOS camera

## Features

DC jack type and terminal block type for power input

## Product Line-up

Model	Monochrome/Color	Resolution	Video Format	Effective Pixels (H x V)	Sensor Size	Cell Size (μm)	Sensor	Lens Mount	General Specifications
STC-S133N-B *	Color	0.65M	NTSC	1280 × 486	1/3.2"	3.5 × 3.5	ISX017	CS	Output: BNC
STC-S133P-B *	Color	0.65M	PAL	1211 × 576	1/3.2"	3.5 × 3.5	ISX017	CS	Output: BNC

\* Select a model from the Line-up list below when ordering.

## Accessories

Mount Conversion Adapter		
Model	Applicable Model	General Specifications
CS-C-R	CS-Mount Model	

Remote Control Unit		
Model	Applicable Model	General Specifications
RC-S133B	S133N-B Series	

Note. Ask your Omron representative about AC adapter.

## Line-up

Model	Monochrome/Color	Sensor Size	Lens Mount	Video Format	General Specifications
STC-S133N-BJ	Color	1/3.2	CS	NTSC	Case, output: BNC
STC-S133P-BJ				PAL	
STC-S133N-BT				NTSC	
STC-S133P-BT				PAL	

Color TV Format

**External Connector Specification**

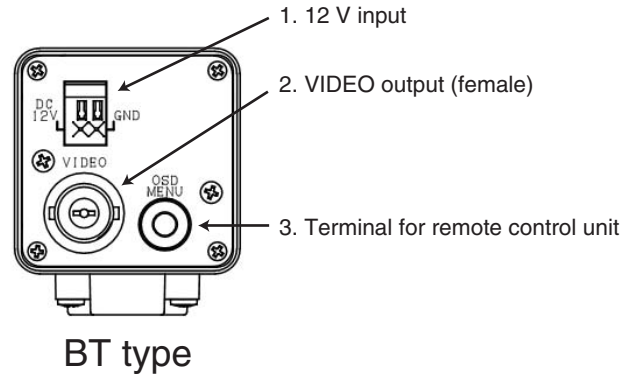
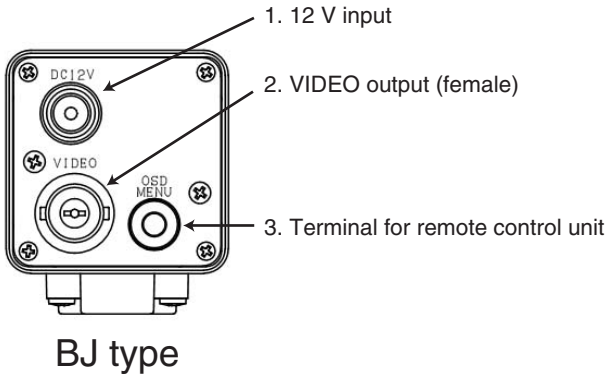

**Drawing dimension**

**BJ type**

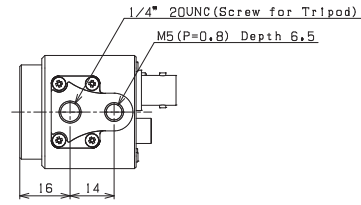
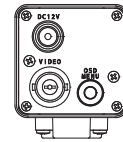
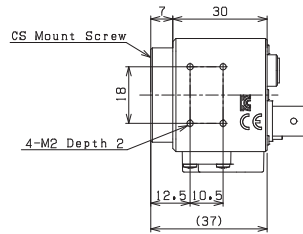
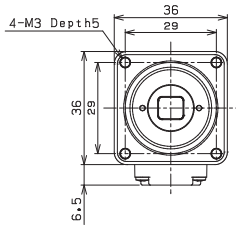

**BT type**

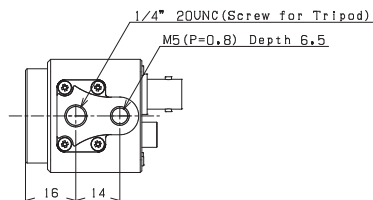
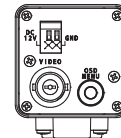
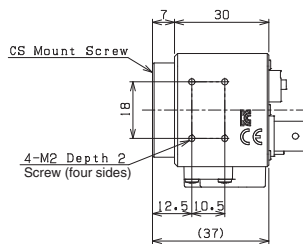
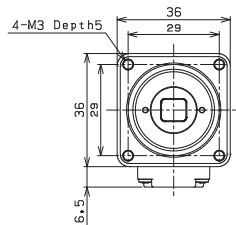

# Small Board Camera STC-S133 Series



## Description

Small Board Camera

## Features

Compact and lightweight camera for integration into machines.  
Select the best interface to suit application

## Product Line-up

Model	Monochrome/Color	Resolution	Effective Pixels (H x V)	Sensor Size	Cell Size (μm)	Sensor	General Specifications
STC-S133N**	Color	0.65M	1280 × 486	1/3.2	3.5 × 3.5	ISX017	NTSC
STC-S133P**	Color	0.65M	1211 × 576	1/3.2	3.5 × 3.5	ISX017	PAL
STC-S133UVC**	Color	1.3M	1280 × 960	1/3.2	3.5 × 3.5	ISX017	USB3.0 (UVC)
STC-S133MIP**	Color	1.3M	1280 × 960	1/3.2	3.5 × 3.5	ISX017	MIPI

\* Select a model from the Line-up list below when ordering.

## Line-up

TV Format (NTSC/PAL)							
Model	Monochrome/Color	Frame Rate	Sensor Size	Lens Mount	General Specifications		
STC-S133N	Color	30fps	1/3.2	---	DPF, Board, Base (without lens mount)		
STC-S133P		25fps		---	DPF, Board, Base (without lens mount)		
STC-S133N-NF		30fps		---	Board, Base (without lens mount), No filter		
STC-S133P-NF		25fps		---	Board, Base (without lens mount), No filter		
STC-S133N-L		30fps		S	DPF, Board, S Mount		
STC-S133N-LS		30fps		S	DPF, Board, S Mount, Lens fixing washer		
STC-S133P-L		25fps		S	DPF, Board, S Mount		
STC-S133N-CS		30fps		CS	DPF, Board, CS Mount		
STC-S133P-CS		25fps		CS	DPF, Board, CS Mount		
STC-S133N-I		30fps		---	IRCF, Board, Base (without lens mount)		
STC-S133P-I		25fps		---	IRCF, Board, Base (without lens mount)		
STC-S133N-IL		30fps		S	IRCF, Board, S Mount		
STC-S133P-IL		25fps		S	IRCF, Board, S Mount		
STC-S133N-ICS		30fps		CS	IRCF, Board, CS Mount		
STC-S133P-ICS		25fps		CS	IRCF, Board, CS Mount		
STC-S133N-ILS		30fps		S	IRCF, Board, S Mount, Lens fixing washer		
STC-S133N-AL		30fps		S	DPF, Case, S Mount		
STC-S133P-AL		25fps		S	DPF, Case, S Mount		
STC-S133N-ACS		30fps		CS	DPF, Case, CS Mount		
STC-S133P-ACS		25fps		CS	DPF, Case, CS Mount		
STC-S133N-IAL		30fps		S	IRCF, Case, S Mount		
STC-S133P-IAL		25fps		S	IRCF, Case, S Mount		
STC-S133N-IACS		30fps		CS	IRCF, Case, CS Mount		
STC-S133P-IACS		25fps		CS	IRCF, Case, CS Mount		

\* DPF: Dual Pass Filter, IRCF: IR Cut Filter

USB3.0(UVC)					
Model	Monochrome/Color	Frame Rate	Sensor Size	Lens Mount	General Specifications
STC-S133UVC-BL	Color	60fps	1/3.2	---	IRCF, Board, Base (without lens mount), Connector from bottom
STC-S133UVC-BLL				S	IRCF, Board, S Mount, Connector from bottom
STC-S133UVC-BLCS				CS	IRCF, Board, CS Mount, Connector from bottom
STC-S133UVC-DBL				---	DPF, Board, Base (without lens mount), Connector from bottom
STC-S133UVC-DBLL				S	DPF, Board, S Mount, Connector from bottom
STC-S133UVC-DBLCS				CS	DPF, Board, CS Mount, Connector from bottom
STC-S133UVC-ALL				S	IRCF, Case, S Mount, Connector from bottom
STC-S133UVC-ALCS				CS	IRCF, Case, CS Mount, Connector from bottom
STC-S133UVC-DALL				S	DPF, Case, S Mount, Connector from bottom
STC-S133UVC-DALCS				CS	DPF, Case, CS Mount, Connector from bottom

\* DPF: Dual Pass Filter, IRCF: IR Cut Filter

MIPI					
Model	Monochrome/Color	Frame Rate	Sensor Size	Lens Mount	General Specifications
STC-S133MIP	Color	60fps	1/3.2	---	IRCF, Board, Base (without lens mount)
STC-S133MIP-CS				CS	IRCF, Board, CS Mount
STC-S133MIP-L				S	IRCF, Board, S Mount
STC-S133MIP-NF				---	IRCF, Board, No filter
STC-S133MIP-D				---	DPF, Board, Base (without lens mount)
STC-S133MIP-DCS				CS	DPF, Board, CS Mount
STC-S133MIP-DL				S	DPF, Board, S Mount
STC-S133MIP-ALL				CS	IRCF, Case, CS Mount
STC-S133MIP-ALCS				S	IRCF, Case, S Mount
STC-S133MIP-DALL				CS	DPF, Case, CS Mount
STC-S133MIP-DALCS				S	DPF, Case, S Mount

\* DPF: Dual Pass Filter, IRCF: IR Cut Filter

## Accessories

Remote Control Unit	
Model	Applicable Model
RC-S133	S133N(P) Series

Mount Conversion Adapter	
Model	Applicable Model
CS-C-R	CS-Mount Models of all S133 Series

Harness for Power Supply/Signal Output		
Model	Applicable Model	General Specifications
KSAF005	For S133N/P	8-pin connector to power pin jack and BNC connector
KSAF006	For S133N/P	8-pin connector to power pin jack and RCA connector

Note. Ask your Omron representative about AC adapter.



STC-S133N(P)-L/LS/IL/ILS

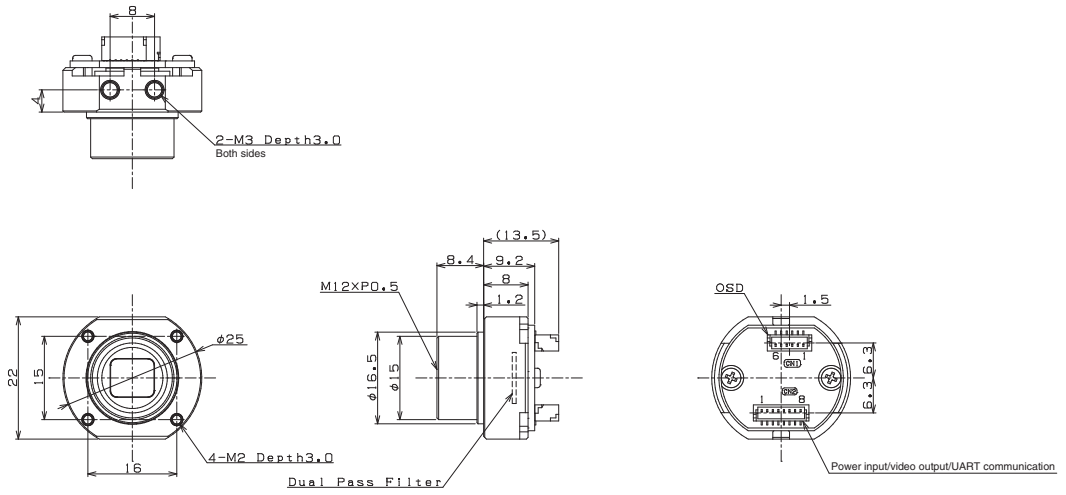

STC-S133N(P)-NF

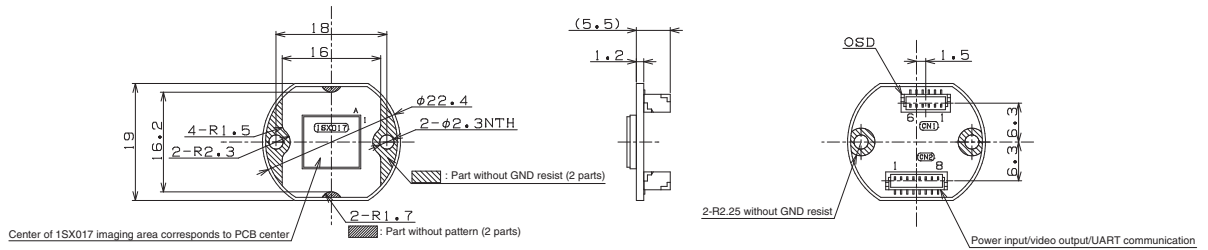

STC-S133N(P)-AL/IAL

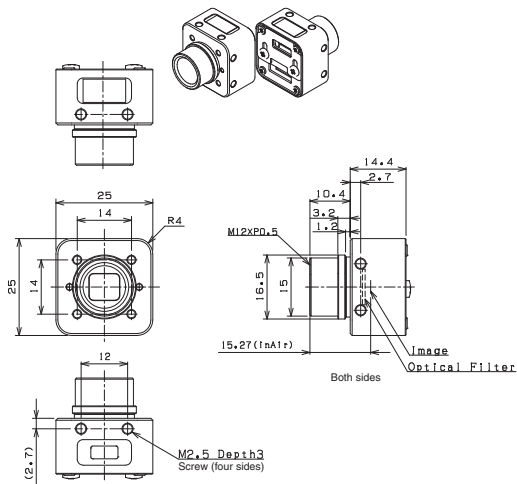

STC-S133N(P)-ACS/IACS

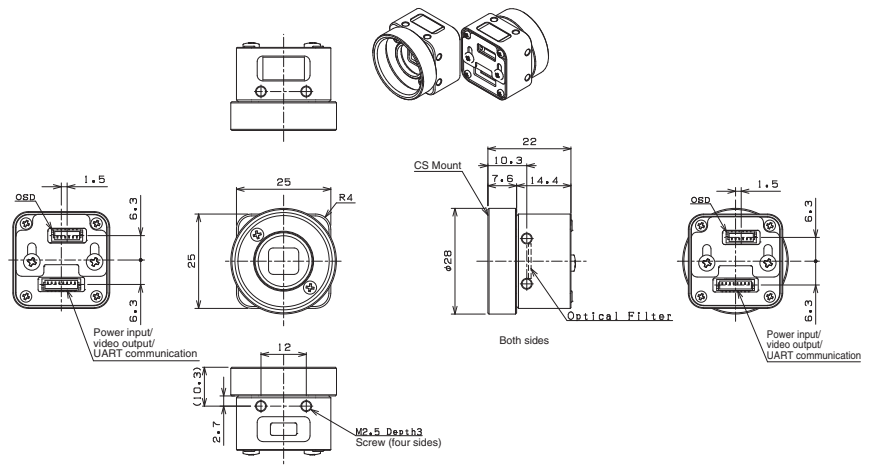





# Line Scanning Camera CameraLink



## Description

Camera Link Line Scan Camera

## Features

A Large Variety of Line-up from 2K to 16K

Single/Dual Line Camera

Easy to Attach in Small Spaces

## Product Line-up

Model	Monochrome/Color	Resolution	Line Rate	Pixel size	Sensor	Sensor Type	Mount	Camera Link connector
FS-B2KU7CLU-C	Monochrome	2048 × 1	80KHz	7um	CMOS	Single	C	MDRx2
FS-B2KU7CLU-F	Monochrome	2048 × 1	80KHz	7um	CMOS	Single	F	MDRx2
FS-B2KU7CLU-M42	Monochrome	2048 × 1	80KHz	7um	CMOS	Single	M42	MDRx2
FS-B4KU7CLU-F	Monochrome	4096 × 1	80KHz	7um	CMOS	Single	F	MDRx2
FS-B4KU7CLU-M42	Monochrome	4096 × 1	80KHz	7um	CMOS	Single	M42	MDRx2
FS-B4KU35CLU-C	Monochrome	4096 × 1	80KHz	3.5um	CMOS	Single	C	MDRx2
FS-B4KU35CLU-F	Monochrome	4096 × 1	80KHz	3.5um	CMOS	Single	F	MDRx2
FS-B4KU35CLU-M42	Monochrome	4096 × 1	80KHz	3.5um	CMOS	Single	M42	MDRx2
FS-B8KU7CLU-M72	Monochrome	8192 × 1	80KHz	7um	CMOS	Single	M72	MDRx2
FS-B8KU35CLU-F	Monochrome	8192 × 1	80KHz	3.5um	CMOS	Single	F	MDRx2
FS-B8KU35CLU-M42	Monochrome	8192 × 1	80KHz	3.5um	CMOS	Single	M42	MDRx2
FS-B16KU35CLU-M72	Monochrome	16384 × 1	40KHz	3.5um	CMOS	Single	M72	MDRx2
FS-B2KU7DCLU-C	Monochrome	2048 × 2	160KHz/80KHz	7um	CMOS	Dual	C	MDRx2
FS-C2KU7DCLU-C	Color							
FS-B4KU7DCLU-F	Monochrome	4096 × 2	160KHz	7um	CMOS	Dual	F	MDRx2
FS-B4KU7DCLU-M42	Monochrome	4096 × 2	160KHz	7um	CMOS	Dual	M42	MDRx2
FS-B8KU7DCLU-M72	Monochrome	8192 × 2	160KHz	7um	CMOS	Dual	M72	MDRx2
FS-B2KU7DCLU-F	Monochrome	2048 × 2	160KHz/80KHz	7um	CMOS	Dual	F	MDRx2
FS-C2KU7DCLU-F	Color							
FS-B2KU7DCLU-M42	Monochrome	2048 × 2	160KHz/80KHz	7um	CMOS	Dual	M42	MDRx2
FS-C2KU7DCLU-M42	Color							
FS-C4KU7DCLU-F	Color	4096 × 2	80KHz	7um	CMOS	Dual	F	MDRx2
FS-C4KU7DCLU-M42	Color	4096 × 2	80KHz	7um	CMOS	Dual	M42	MDRx2
FS-C8KU7DCLU-M72	Color	8192 × 2	40KHz	7um	CMOS	Dual	M72	MDRx2

Note. Ask your Omron representative about AC adapter.

## External Connector Specification

External Connectors

Camera Link Connector:MDR,Power supply:HR10A-7R-6PB(Hirose) or equivalent

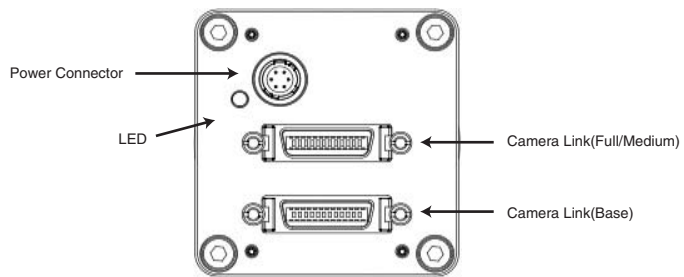

Pin No.	Signal name	IN/OUT	Voltage
1	+12V	IN	+12V
2	+12V	IN	+12V
3	+12V	IN	+12V
4	GND		
5	GND		
6	GND		

\*Please use HR10A-7P-6S or equivalent for the cable  
 \*Differed by models. Please see below specifications.

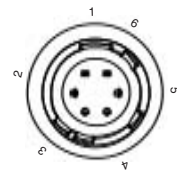

## Drawing dimension

### C Mount Type

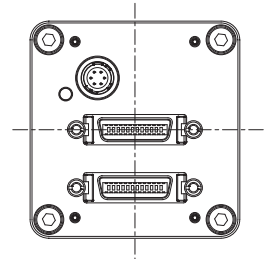
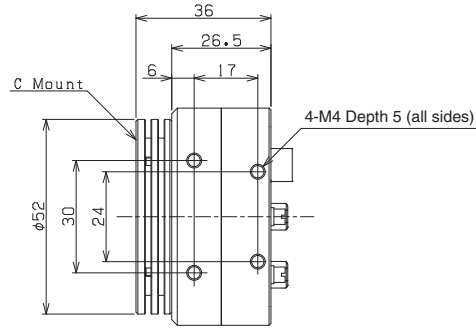
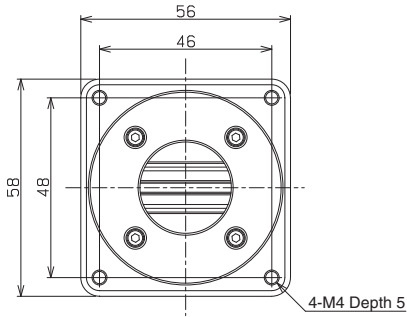
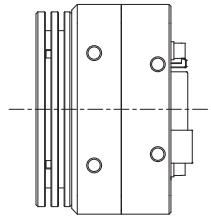
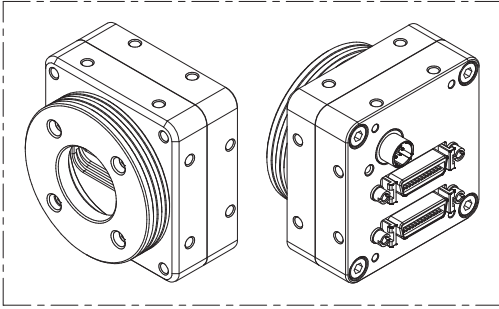

### F Mount Type

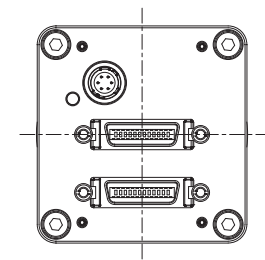
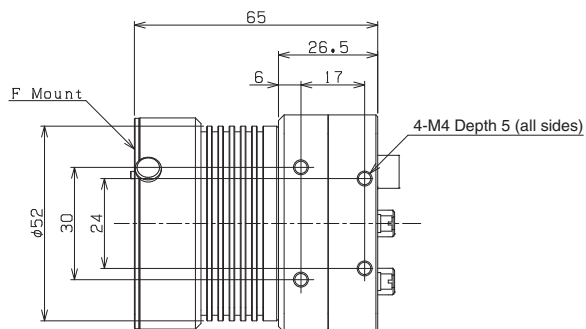
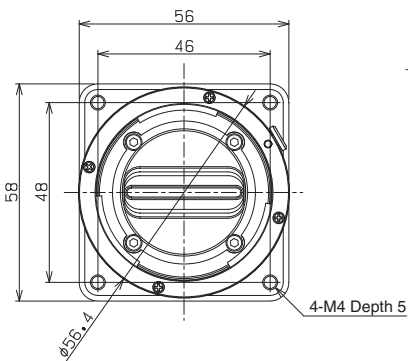
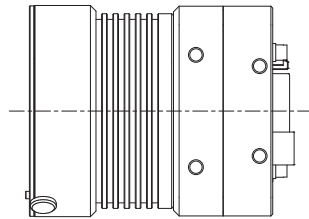
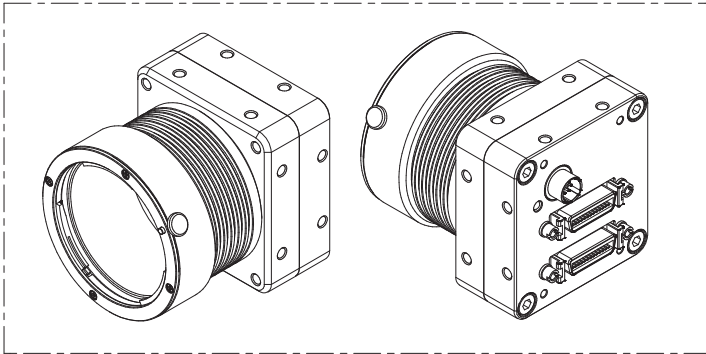

### M42 Mount Type

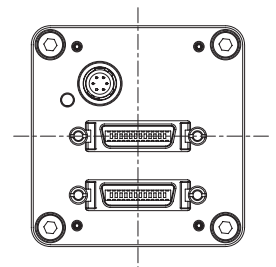
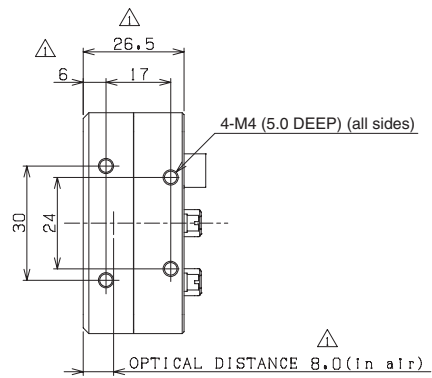
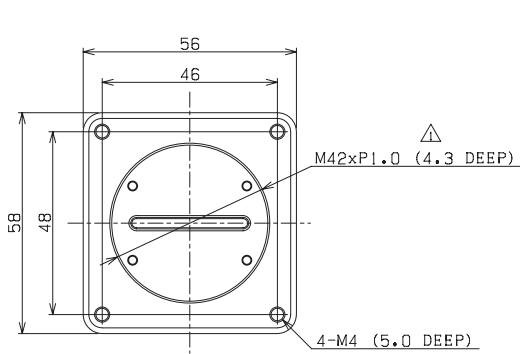
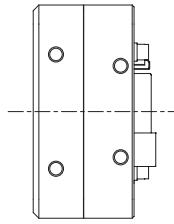
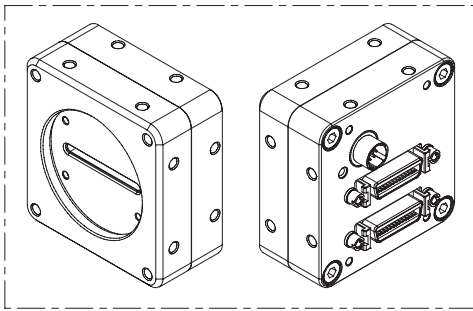

### M72 Mount Type

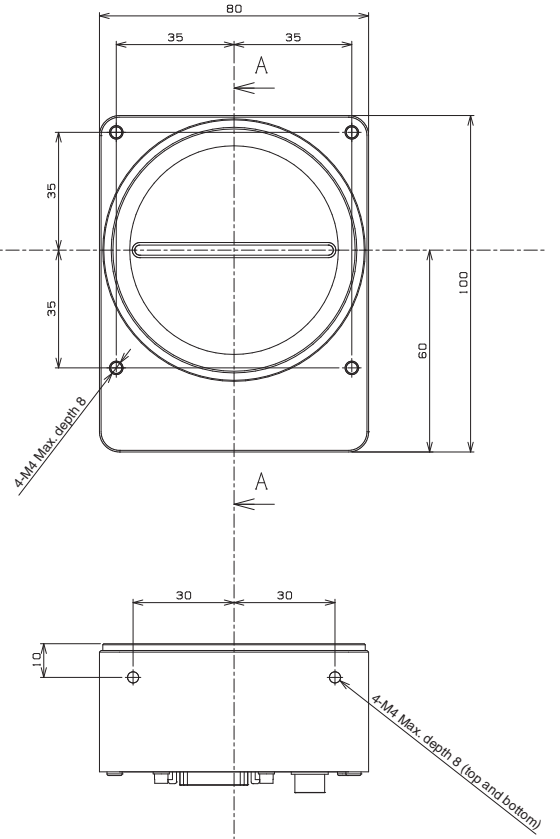
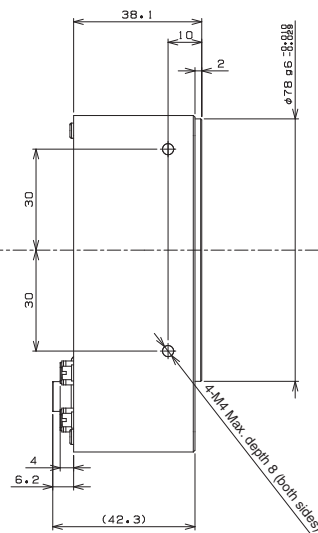
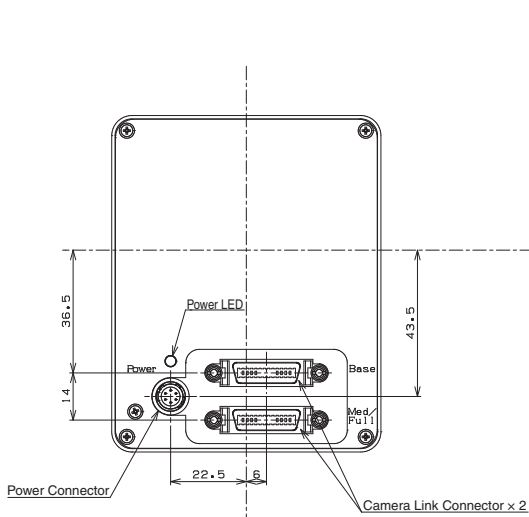

## Accessory ,Cable, others



### Description

Optional items for using cameras cables are arranged

### Screw-fastened USB3.0 Cable

Sentech has made available a line of optional screw-fastened cables, responding to many requests for such cables when using USB cameras in the FA field. Cable with lock screw for USB 3.0 and cable with robot cable specifications are available.



Model	Applicable Model	General Specifications
NU3MBASU3S-2m	All USB3.0 Cameras	2m, USB 3.0 MicroB, with camera-side fastening screws, normal cables
NU3MBASU3S-3.5m	All USB3.0 Cameras	3.5m, USB 3.0 MicroB, with camera-side fastening screws, normal cables
NU3MBASU3B-2m	All USB3.0 Cameras	2m, USB 3.0 MicroB, with camera-side fastening screws, robot cables
NU3MBASU3B-3.5m	All USB3.0 Cameras	3.5m, USB 3.0 MicroB, with camera-side fastening screws, robot cables

\*Please make sure that USB 3.0 cables operate correctly under your environment beforehand

### Harness for Power Supply/Signal Output

Harnesses for power supply and signal output for STC-S133N.



Model	Applicable Model	General Specifications
KSAF005	For S133N/P	8-pin connector to power pin jack and BNC connector
KSAF006	For S133N/P	8-pin connector to power pin jack and RCA connector

### Mount Conversion Adapter



Adapter ring necessary when using C-mount lens with CS-mount camera  
 Converting adapter from M42 P=1 FB=10mm to F-mount

Model	Applicable Model	General Specifications
CS-C-R	CS-Mount Model	CS-Mount Model
M42-F-R	12M	M42 P=1 FB=10 mm → F mount conversion adapter

### Tripod Mount



Optional adapter for fastening the camera with tripod screws

Model	Applicable Model	General Specifications
TP-HCA*	STC-MCE/MBE132U3V, STC-MCA/MBA5MUSB3	
TP-JVA	STC-MCE/MBE132, STC-MBA/MCA5MUSB3, Analogue	
TP-KWA	GigE Vision M Series	
TP-KWA-IEA	GigE Vision M Series	Used to set M Series with sensor center at same height as that of S Series

\* The tripod mount is screwed at two points on the lens side.

### Remote Control Unit



The unit is connected to the pin jack on the back of the camera allowing various settings to be made with an on-screen display. All DVI/SDI models are applicable.

Model	Applicable Model	General Specifications
RC-HD133	HDMI/DVI/SDI	ø3.5 stereo pin jack-USB miniB
RC-S133	S133N/P Series	
RC-S133B	S133N-B Series	

## Accessory Fixed Focus Lens

---



### Description

Small-diameter fixed focus lens for board cameras and remote head camera

### Lens for Small Board Cameras



Model	Applicable Model	General Specifications
CV0205C	STC-S133 Series, USB2.0 Models	f=2.5 mm, 1/3", F2.0, for 5M resolution

# USB 3.0 4ch Frame Grabber Board

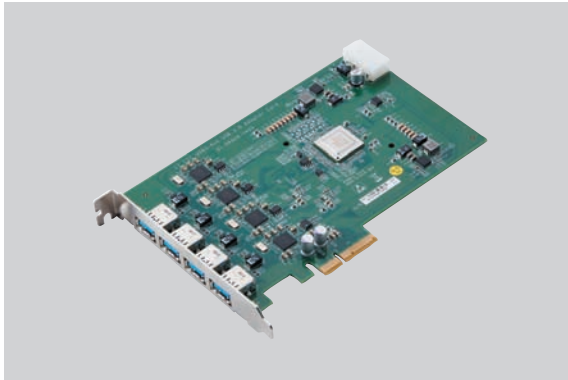

## Description

4ch Frame Grabber Board for USB 3.0 Camera

## Features

The 4-channel Frame Grabber Board includes the USB3.0 chips on each channel.

Adopting PCI Express Gen 3 × 4 lane connections, operation with greater stability than Gen 2 × 4 lane models can be ensured when using multiple high resolution, high-speed cameras.

## Product Line-up

Model	USB3-4ch
No. of ports	USB3.0 Standard A × 4 ports
Host I/F	PCI Express Gen3 × 4 lane
Operating power supply	On-board 5 VDC
Host controller	FL1100-1Q0-EX (FRESCO)
Supported OS	Windows7/8/10 and Linux
Motion camera	Omron Sentech USB3.0 Camera
Dimensions	167 (W) × 111.15 (H) mm (excluding protrusions)

\*Confirm operation with your PC in advance.

\*Use the latest USB driver version provided by FRESCO Logic.

## Spectral Characteristics Chart

This is the Spectral Characteristics Chart of the image sensor (CCD/CMOS) published in this catalog

	Model	Type	Page
1	IMX287	Monochrome	48
2	IMX273	Monochrome	48
3	IMX174	Monochrome	48
4	IMX430	Monochrome	48
5	IMX249	Monochrome	48
6	IMX265	Monochrome	49
7	IMX252	Monochrome	49
8	IMX264	Monochrome	49
9	IMX250	Monochrome	49
10	IMX267	Monochrome	49
11	IMX255	Monochrome	49
12	IMX304	Monochrome	49
13	IMX253	Monochrome	49
14	IMX226	Monochrome	50
15	IMX183	Monochrome	50
16	CMV300	Monochrome	51
17	CMV2000	Monochrome	51
18	CMV4000	Monochrome	51
19	CMV12000	Monochrome	52
20	MT9P031	Monochrome	52
21	EV76C560ACT	Monochrome	52
22	RJ33B4AA0DT	Monochrome	52
23	CMV2000	NIR	51
24	CMV4000	NIR	51

	Model	Type	Page
25	IMX287	Color	48
26	IMX273	Color	48
27	IMX174	Color	48
28	IMX430	Color	48
29	IMX249	Color	48
30	IMX265	Color	49
31	IMX252	Color	49
32	IMX264	Color	49
33	IMX250	Color	49
34	IMX267	Color	49
35	IMX255	Color	49
36	IMX304	Color	49
37	IMX253	Color	49
38	IMX226	Color	50
39	IMX274	Color	50
40	IMX183	Color	50
41	ISX017	Color	50
42	IMX136	Color	50
43	CMV300	Color	51
44	CMV2000	Color	51
45	CMV4000	Color	51
46	CMV12000	Color	52
47	MT9P031	Color	52
48	EV76C560ACT	Color	52

## IMX287

1/2.9" CMOS 0.4M Monochrome

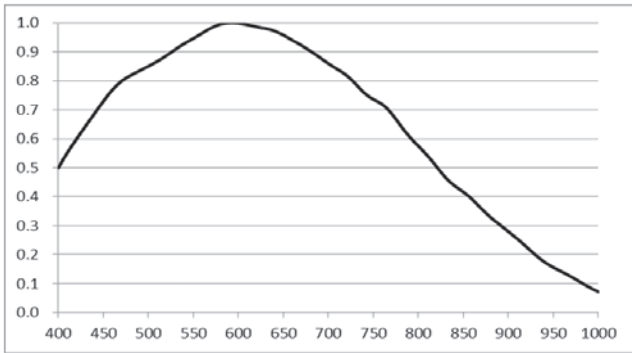

## IMX287

1/2.9" CMOS 0.4M Color

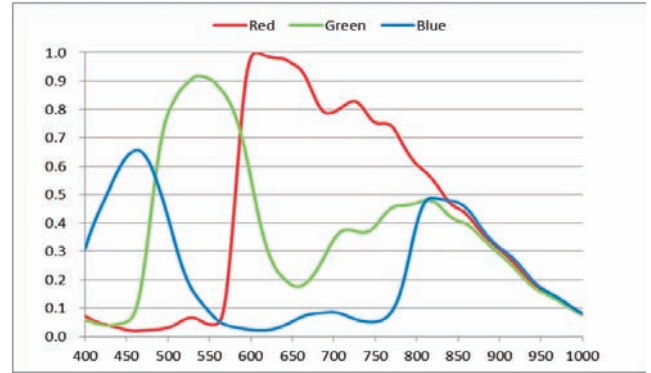

## IMX273

1/2.9" CMOS 1.6M Monochrome

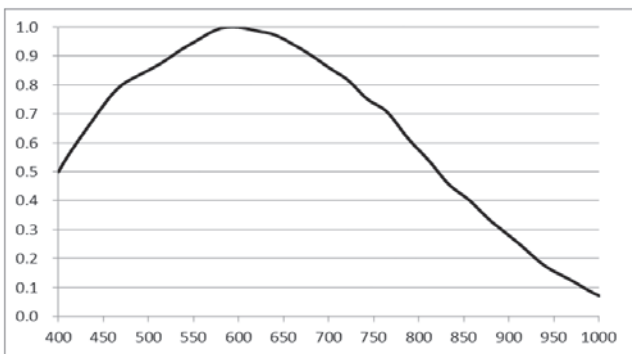

## IMX273

1/2.9" CMOS 1.6M Color

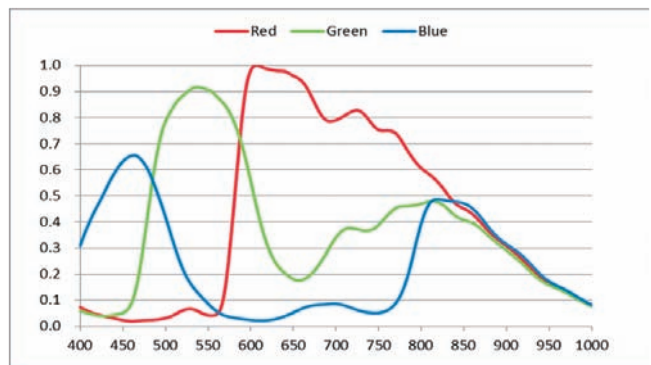

## IMX174, IMX249

1/1.2" CMOS 2.3M Monochrome

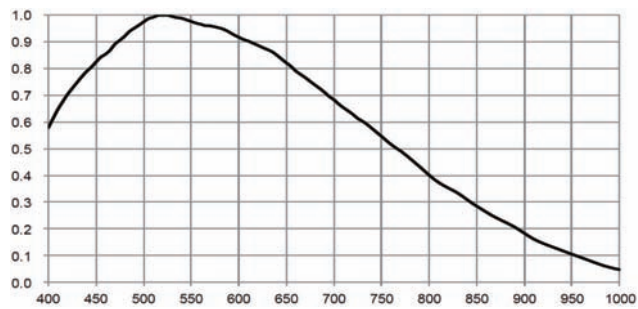

## IMX174, IMX249

1/1.2" CMOS 2.3M Color

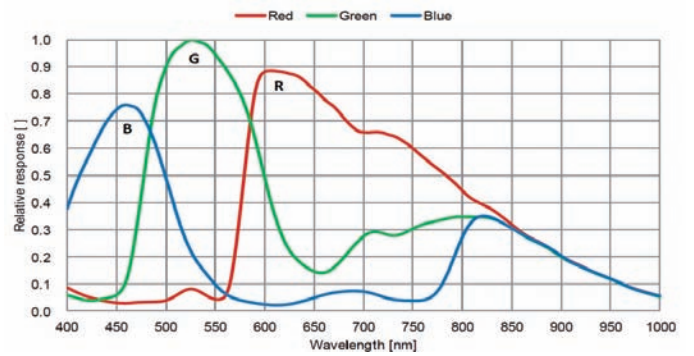

## IMX430

1/1.7" CMOS 2M Monochrome

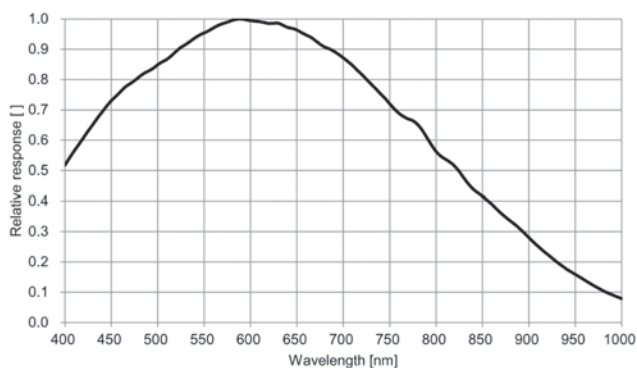

## IMX430

1/1.7" CMOS 2M Color

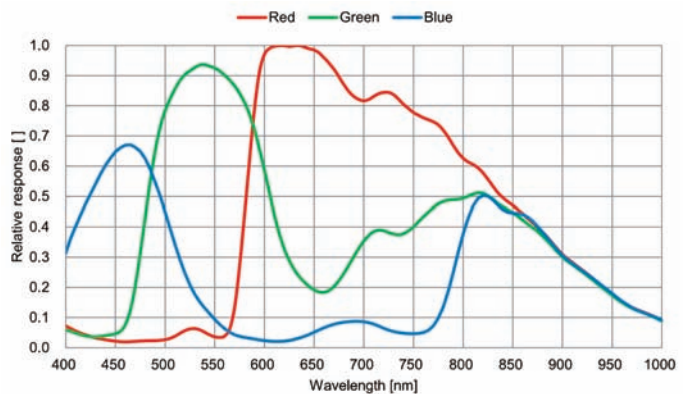

### IMX265, IMX252

1/1.8" CMOS 3.2M Monochrome

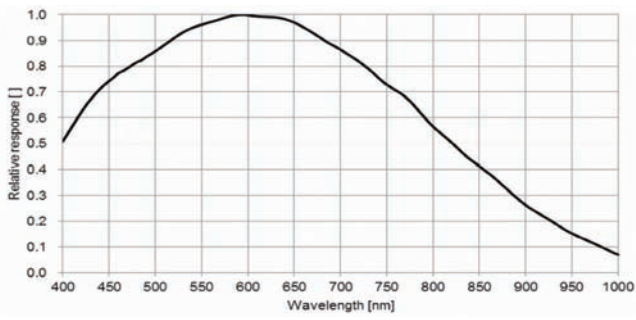

### IMX265, IMX252

1/1.8" CMOS 3.2M Color

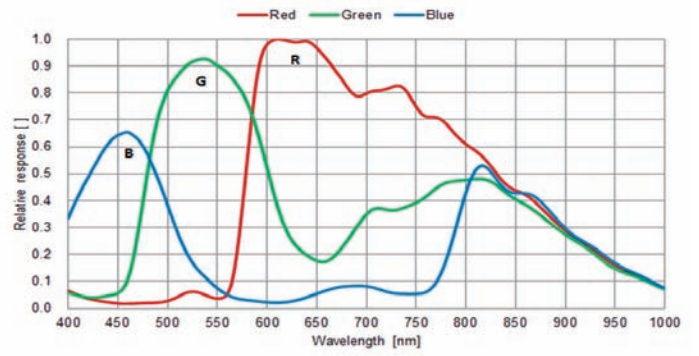

### IMX264, IMX250

2/3" CMOS 5M Monochrome

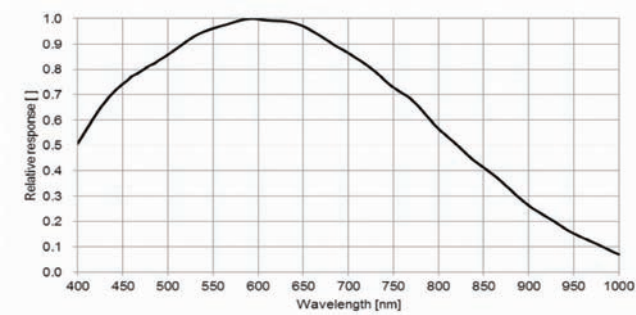

### IMX264, IMX250

2/3" CMOS 5M Color

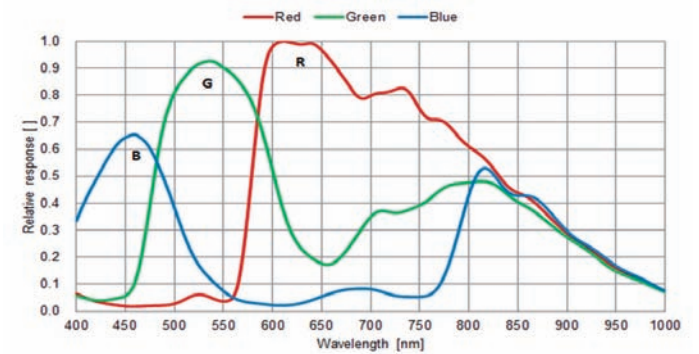

### IMX267 / IMX255

1" CMOS 8.9M Monochrome

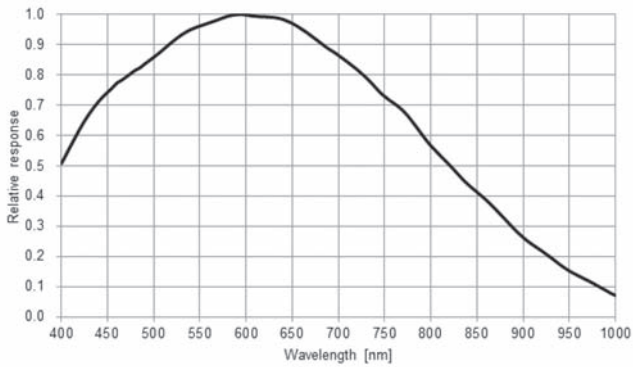

### IMX267 / IMX255

1" CMOS 8.9M Color

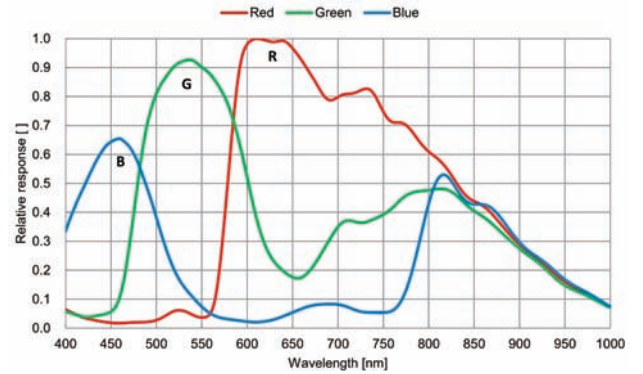

### IMX304 / IMX253

1.1" CMOS 12M Monochrome

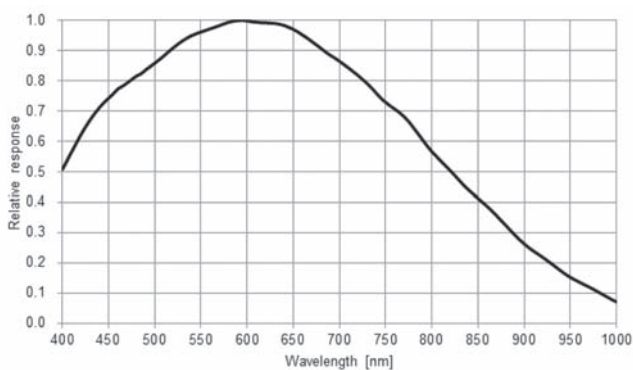

### IMX304 / IMX253

1.1" CMOS 12M Color

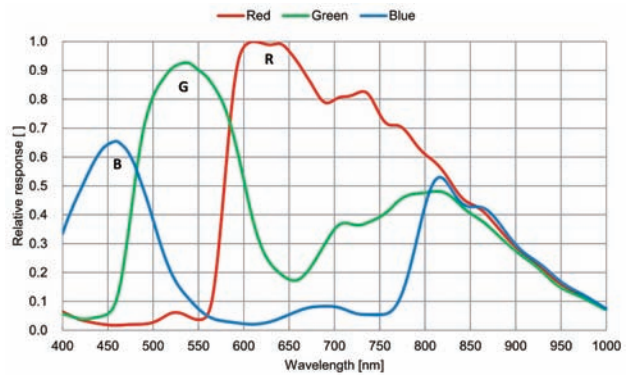

### IMX274

1/2.5" CMOS 8.3M Color

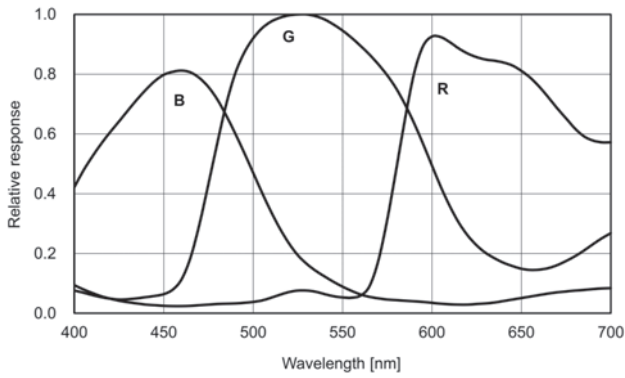

### IMX226

1/1.7" CMOS 12M Monochrome

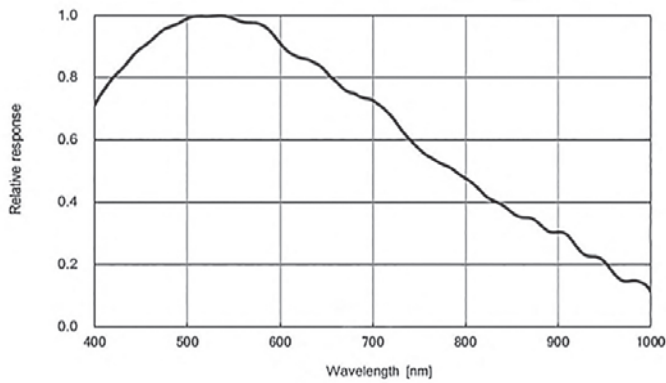

### IMX226

1/1.7" CMOS 12M Color

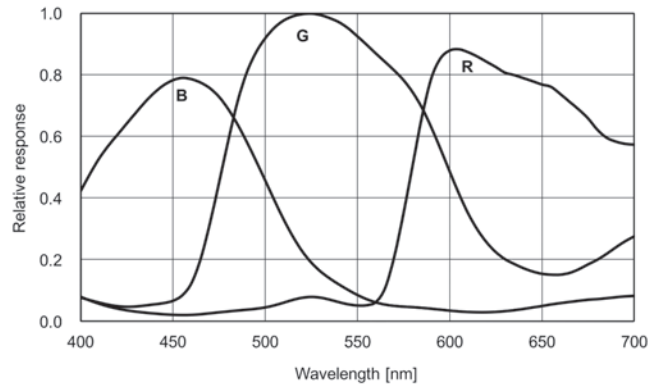

### IMX183

1" CMOS 20M Monochrome

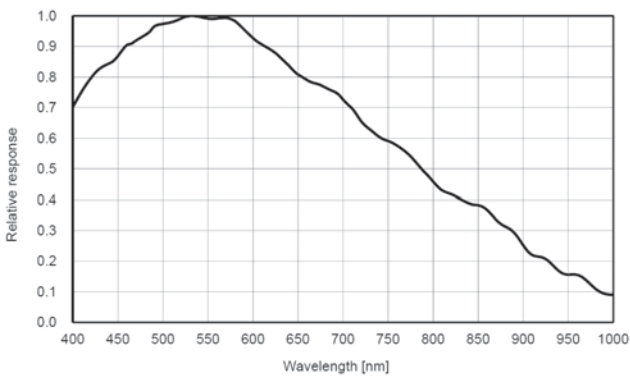

### IMX183

1" CMOS 20M Color

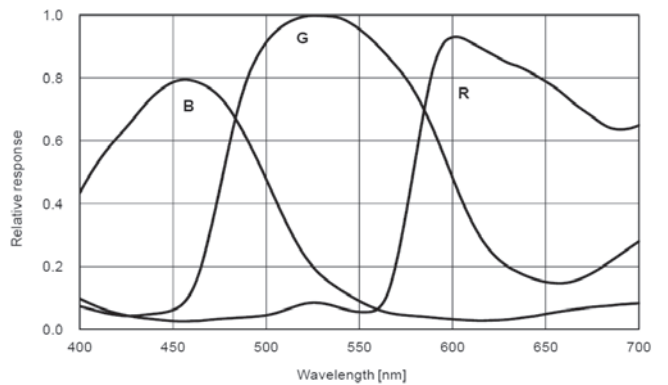

### ISX017

1/3.2" CMOS 0.6M Color

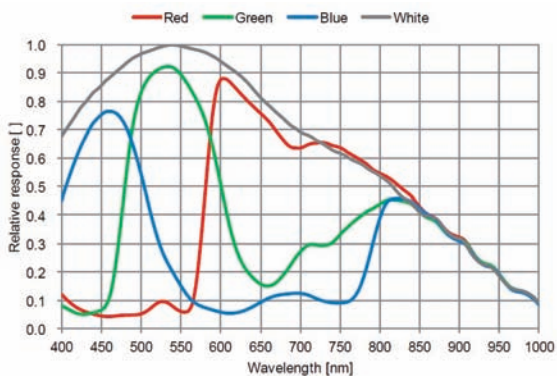

### IMX136

1/2.8" CMOS 1080P FULL High-definition Color

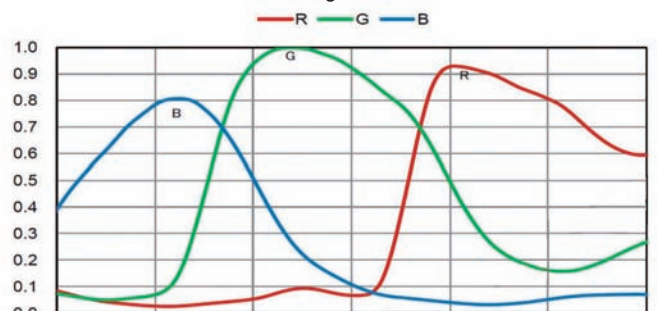

1/3" CMOS VGA Monochrome, Color

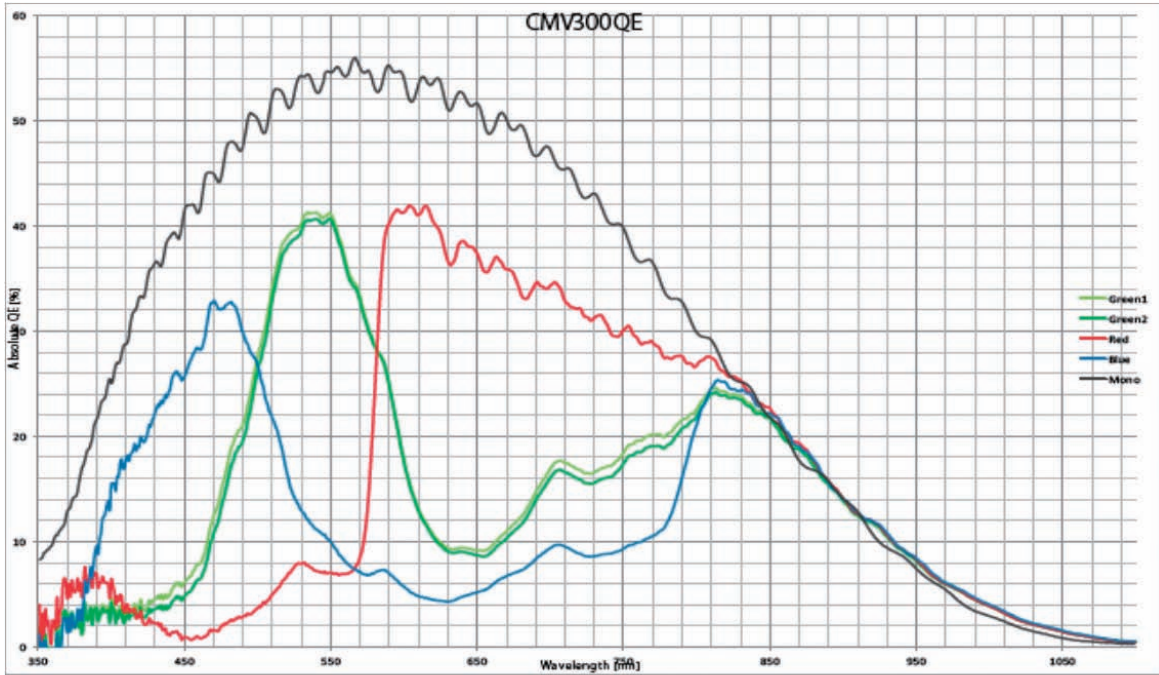

CMV2000 / CMV4000

2/3" CMOS 2M Monochrome / 1" CMOS 4M Monochrome

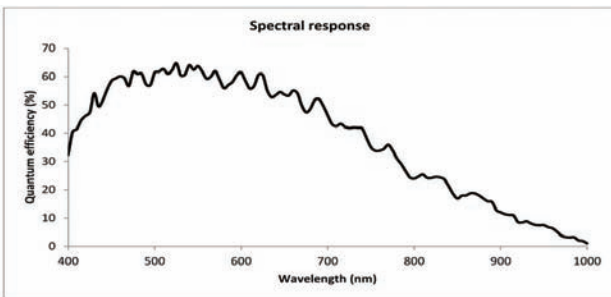

CMV2000 / CMV4000

2/3" CMOS 2M Color / 1" CMOS 4M Color

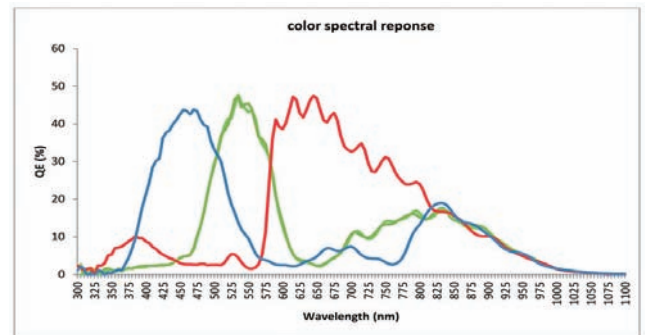

CMV2000 / CMV4000

2/3" CMOS 2M NIR / 1" CMOS 4M NIR

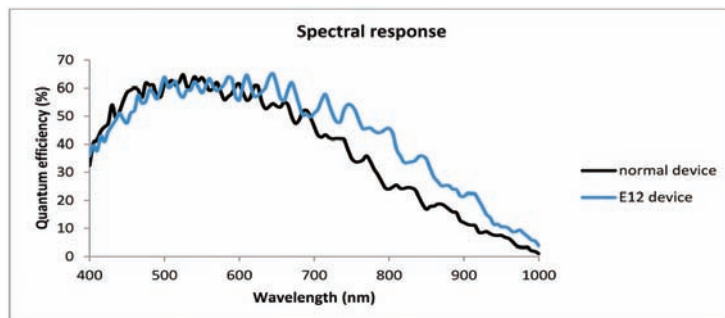

**CMV12000**

**CMV12000**

1.76" CMOS 12M Monochrome, Color

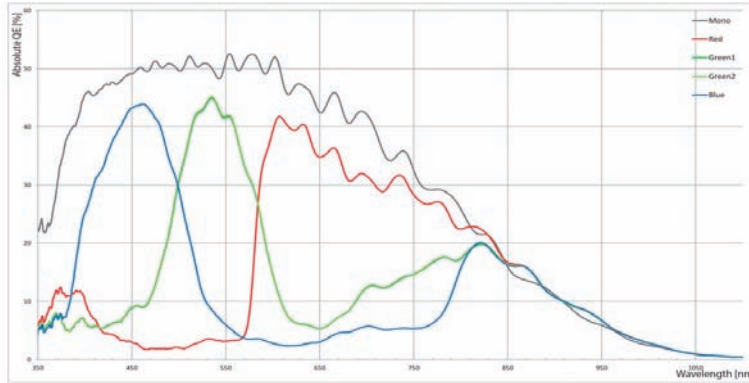

**EV76C560ACT**

**EV76C560ACT**

1/1.8" CMOS 1.3M Monochrome, Color

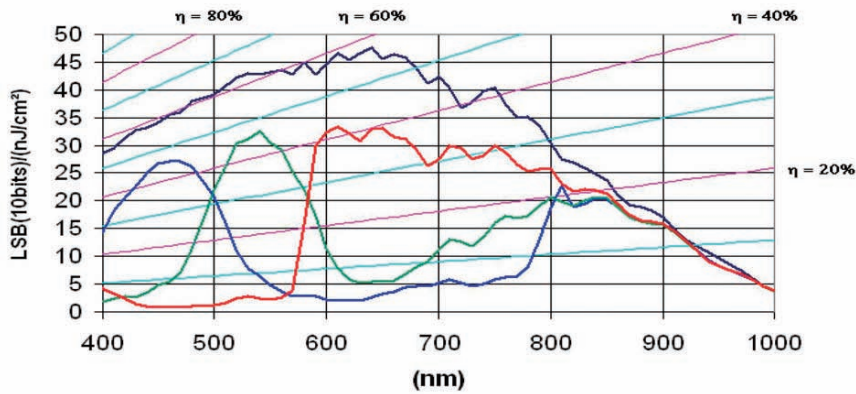

**MT9P031**

1/2.5" CMOS 5M Monochrome

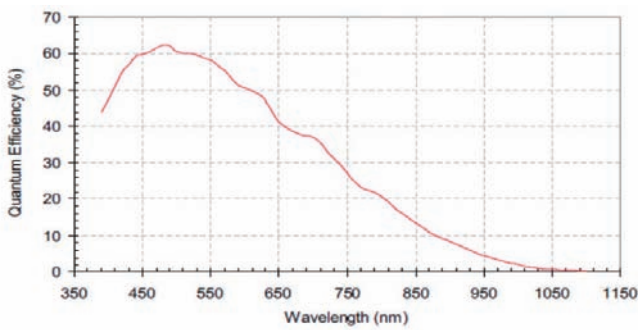

**MT9P031**

1/2.5" CMOS 5M Color

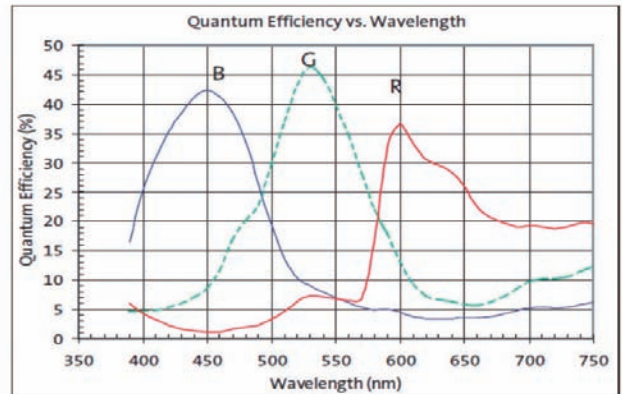

**RJ33B4AA0DT**

1/3" CCD VGA Monochrome

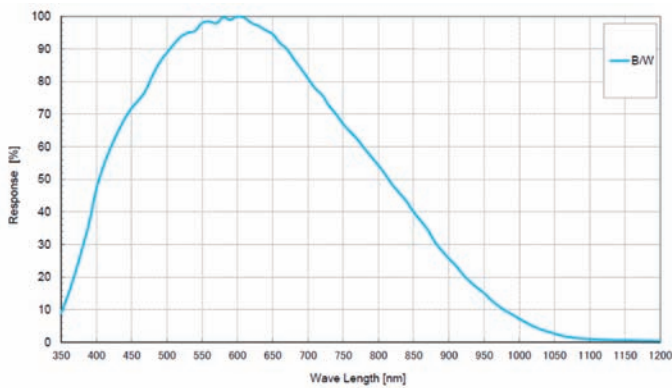

## Trademarks

---

- \* Camera Link, GigE Vision, USB3Vision, and PoCL are registered trademarks of AIA (Automated Imaging Association).
- \* CoaXPress is a registered trademark of JIIA (Japan Industrial Imaging Association).
- \* Opt-C:Link is a registered trademark of AVAL DATA CORPORATION.
- \* Windows and Microsoft Visual Studio are either registered trademarks or trademarks of Microsoft Corporation in the United States and/or other countries.
- \* The terms HDMI, HDMI High-Definition Multimedia Interface, and the HDMI Logo are trademarks or registered trademarks of HDMI Licensing Administrator, Inc.
- \* Other company names and product names in this document are the trademarks or registered trademarks of their respective companies.

# Terms and Conditions Agreement

## Read and understand this catalog.

Please read and understand this catalog before purchasing the products. Please consult your OMRON representative if you have any questions or comments.

## Warranties.

- (a) Exclusive Warranty. Omron's exclusive warranty is that the Products will be free from defects in materials and workmanship for a period of twelve months from the date of sale by Omron (or such other period expressed in writing by Omron). Omron disclaims all other warranties, express or implied.
- (b) Limitations. OMRON MAKES NO WARRANTY OR REPRESENTATION, EXPRESS OR IMPLIED, ABOUT NON-INFRINGEMENT, MERCHANTABILITY OR FITNESS FOR A PARTICULAR PURPOSE OF THE PRODUCTS. BUYER ACKNOWLEDGES THAT IT ALONE HAS DETERMINED THAT THE PRODUCTS WILL SUITABLY MEET THE REQUIREMENTS OF THEIR INTENDED USE.

Omron further disclaims all warranties and responsibility of any type for claims or expenses based on infringement by the Products or otherwise of any intellectual property right. (c) Buyer Remedy. Omron's sole obligation hereunder shall be, at Omron's election, to (i) replace (in the form originally shipped with Buyer responsible for labor charges for removal or replacement thereof) the non-complying Product, (ii) repair the non-complying Product, or (iii) repay or credit Buyer an amount equal to the purchase price of the non-complying Product; provided that in no event shall Omron be responsible for warranty, repair, indemnity or any other claims or expenses regarding the Products unless Omron's analysis confirms that the Products were properly handled, stored, installed and maintained and not subject to contamination, abuse, misuse or inappropriate modification. Return of any Products by Buyer must be approved in writing by Omron before shipment. Omron Companies shall not be liable for the suitability or unsuitability or the results from the use of Products in combination with any electrical or electronic components, circuits, system assemblies or any other materials or substances or environments. Any advice, recommendations or information given orally or in writing, are not to be construed as an amendment or addition to the above warranty.

See <http://www.omron.com/global/> or contact your Omron representative for published information.

## Limitation on Liability; Etc.

OMRON COMPANIES SHALL NOT BE LIABLE FOR SPECIAL, INDIRECT, INCIDENTAL, OR CONSEQUENTIAL DAMAGES, LOSS OF PROFITS OR PRODUCTION OR COMMERCIAL LOSS IN ANY WAY CONNECTED WITH THE PRODUCTS, WHETHER SUCH CLAIM IS BASED IN CONTRACT, WARRANTY, NEGLIGENCE OR STRICT LIABILITY.

Further, in no event shall liability of Omron Companies exceed the individual price of the Product on which liability is asserted.

## Suitability of Use.

Omron Companies shall not be responsible for conformity with any standards, codes or regulations which apply to the combination of the Product in the Buyer's application or use of the Product. At Buyer's request, Omron will provide applicable third party certification documents identifying ratings and limitations of use which apply to the Product. This information by itself is not sufficient for a complete determination of the suitability of the Product in combination with the end product, machine, system, or other application or use. Buyer shall be solely responsible for determining appropriateness of the particular Product with respect to Buyer's application, product or system. Buyer shall take application responsibility in all cases.

NEVER USE THE PRODUCT FOR AN APPLICATION INVOLVING SERIOUS RISK TO LIFE OR PROPERTY OR IN LARGE QUANTITIES WITHOUT ENSURING THAT THE SYSTEM AS A WHOLE HAS BEEN DESIGNED TO ADDRESS THE RISKS, AND THAT THE OMRON PRODUCT(S) IS PROPERLY RATED AND INSTALLED FOR THE INTENDED USE WITHIN THE OVERALL EQUIPMENT OR SYSTEM.

## Programmable Products.

Omron Companies shall not be responsible for the user's programming of a programmable Product, or any consequence thereof.

## Performance Data.

Data presented in Omron Company websites, catalogs and other materials is provided as a guide for the user in determining suitability and does not constitute a warranty. It may represent the result of Omron's test conditions, and the user must correlate it to actual application requirements. Actual performance is subject to the Omron's Warranty and Limitations of Liability.

## Change in Specifications.

Product specifications and accessories may be changed at any time based on improvements and other reasons. It is our practice to change part numbers when published ratings or features are changed, or when significant construction changes are made. However, some specifications of the Product may be changed without any notice. When in doubt, special part numbers may be assigned to fix or establish key specifications for your application. Please consult with your Omron's representative at any time to confirm actual specifications of purchased Product.

## Errors and Omissions.

Information presented by Omron Companies has been checked and is believed to be accurate; however, no responsibility is assumed for clerical, typographical or proofreading errors or omissions.

Note: Do not use this document to operate the Unit.

**OMRON Corporation Industrial Automation Company**  
Kyoto, JAPAN

Contact: [www.ia.omron.com](http://www.ia.omron.com)

**Regional Headquarters**

**OMRON EUROPE B.V.**

Wegalaan 67-69, 2132 JD Hoofddorp  
The Netherlands  
Tel: (31)2356-81-300/Fax: (31)2356-81-388

**OMRON ELECTRONICS LLC**

2895 Greenspoint Parkway, Suite 200  
Hoffman Estates, IL 60169 U.S.A.  
Tel: (1) 847-843-7900/Fax: (1) 847-843-7787

**OMRON ASIA PACIFIC PTE. LTD.**

No. 438A Alexandra Road # 05-05/08 (Lobby 2),  
Alexandra Technopark,  
Singapore 119967  
Tel: (65) 6835-3011/Fax: (65) 6835-2711

**OMRON (CHINA) CO., LTD.**

Room 2211, Bank of China Tower,  
200 Yin Cheng Zhong Road,  
PuDong New Area, Shanghai, 200120, China  
Tel: (86) 21-5037-2222/Fax: (86) 21-5037-2200

**Authorized Distributor:**

© OMRON Corporation 2017-2020 All Rights Reserved.  
In the interest of product improvement,  
specifications are subject to change without notice.

**Cat. No. Q259-E1-04**

0320(1117)