



SEW
EURODRIVE

Compact Operating Instructions



MOVIMOT[®] MM..D
with AC Motor DT/DV





Contents

1	General Information	4
1.1	Scope of this documentation	4
1.2	Structure of the safety notes	4
2	Safety Notes	5
2.1	General information	5
2.2	Target group	5
2.3	Designated use	5
2.4	Transportation, storage	6
2.5	Installation	6
2.6	Electrical connection	6
2.7	Safe disconnection	7
2.8	Operation	7
3	Type Designations	8
3.1	Sample motor nameplate	8
3.2	Sample inverter nameplate	9
3.3	Unit identification	9
3.4	"Mounting close to the motor" design	10
4	Mechanical Installation	11
4.1	MOVIMOT® gearmotor	11
4.2	Installing the MOVIMOT® inverter close to the motor	13
4.3	Tightening torques	14
5	Electrical Installation	16
5.1	Installation instructions	16
5.2	Connection of MOVIMOT®	20
5.3	Connection between MOVIMOT® and motor when mounted close to the motor	21
6	Startup	24
6.1	Important notes on startup	24
6.2	Description of the controls	25
6.3	Description of the DIP switches S1	28
6.4	Description of DIP switches S2	30
6.5	Startup with binary control	33
6.6	Supplementary notes for installation close to the motor	35
7	Startup with RS-485 Interface/Fieldbus	38
7.1	Important notes on startup	38
7.2	Startup procedure	38
8	Operation	41
8.1	Operating display	41
9	Service	42
9.1	Status and error display	42
9.2	Replacing units	45
10	Declaration of Conformity	46



1 General Information











1.1 Scope of this documentation

This documentation contains the general safety notes and selected information regarding MOVIMOT® MM..D with AC motor DT/DV.

- Please note that this documentation does not replace the detailed operating instructions.
- Read the detailed operating instructions before you start working with MOVIMOT® MM..D.
- Observe the information, instructions and notes in the detailed operating instructions and the "AC Motors DR/DV/DT/DTE/DVE" operating instructions. This is essential for fault-free operation of MOVIMOT® MM..D and fulfillment of any rights to claim under guarantee.
- The enclosed CD or DVD contains PDF files of the additional operating instructions as well as further MOVIMOT® MM..D documentation.
- All SEW-EURODRIVE's technical documentation is available to download in PDF format from the SEW-EURODRIVE website: www.sew-eurodrive.de.

1.2 Structure of the safety notes

The safety notes in these operating instructions are structured as follows:

Pictogram 	 SIGNAL WORD		
	Type and source of danger. Possible consequence(s) if disregarded. • Measure(s) to prevent the danger.		
Pictogram	Signal word	Meaning	Consequences if disregarded
Example:  General danger	 DANGER	Imminent danger	Severe or fatal injuries
 Specific danger, e.g. electric shock	 WARNING	Possible dangerous situation	Severe or fatal injuries
 Specific danger, e.g. electric shock	 CAUTION	Possible dangerous situation	Minor injuries
	NOTICE	Possible damage to property	Damage to the drive system or its environment
	INFORMATION	Useful information or tip. Simplifies the handling of the drive system.	



2 Safety Notes

The following basic safety notes must be read carefully to prevent injury to persons and damage to property. The operator must ensure that the basic safety notes are read and observed. Make sure that persons responsible for the plant and its operation, as well as persons who work independently on the unit, have read through the operating instructions carefully and understood them. If you are unclear about any of the information in this documentation, please contact SEW-EURODRIVE.

2.1 General information

Never install or start up damaged products. Submit a complaint to the shipping company immediately in the event of damage.

During operation, MOVIMOT® drives can have live, bare and movable or rotating parts as well as hot surfaces, depending on their enclosure.

Removing covers without authorization, improper use as well as incorrect installation or operation may result in severe injuries to persons or damage to property. Refer to the documentation for additional information.

2.2 Target group

Only qualified electricians are authorized to install, startup or service the units or correct unit faults (observing IEC 60364 or CENELEC HD 384 or DIN VDE 0100 and IEC 60664 or DIN VDE 0110 as well as national accident prevention guidelines).

Qualified personnel in the context of these basic safety notes are persons familiar with installation, assembly, startup and operation of the product who possess the necessary qualifications.

Any activities regarding transportation, storage, operation, and disposal must be carried out by persons who have been instructed appropriately.

2.3 Designated use

MOVIMOT® drives are components intended for installation in electrical systems or machines.

In case of installation in machines, startup of MOVIMOT® inverters (i.e. start of designated operation) is prohibited until it is determined that the machine meets the requirements stipulated in the EC Directive 2006/42/EC (machine directive).

Startup (i.e. the start of designated use) is only permitted under observance of the EMC directive 2004/108/EC.

MOVIMOT® inverters comply with the regulations of the Low Voltage Directive 2006/95/EC. The standards given in the declaration of conformity are used for MOVIMOT® inverters.

You must observe the technical data and information on the connection requirements as provided on the nameplate and in the documentation.



2.3.1 Safety functions

The MOVIMOT[®] inverter may not perform safety functions unless these functions are described and expressly permitted.

For safety functions, ensure that the information in the supplied publications is observed.

Use only components in safety applications that were explicitly designed and supplied for this purpose by SEW-EURODRIVE.

2.3.2 Hoist applications

When using MOVIMOT[®] inverters in hoist applications, you must observe the special configuration and settings for hoist applications specified in the operating instructions for MOVIMOT[®].

MOVIMOT[®] inverters may not be used as a safety device in hoist applications.

2.4 *Transportation, storage*

You must observe the notes on transportation, storage and proper handling. Comply with the requirements for climatic conditions stated in chapter "Technical Data" of the operating instructions. Tighten installed eyebolts securely. They are designed for the weight of the MOVIMOT[®] drive. Do not attach any additional loads. Use suitable, sufficiently rated handling equipment (e.g. rope guides) if required.

2.5 *Installation*

The units must be installed and cooled according to the regulations and specifications in the corresponding documentation.

Protect the MOVIMOT[®] inverters from improper strain.

The following applications are prohibited unless the unit is explicitly designed for such use:

- Use in potentially explosive atmospheres.
- Use in areas exposed to harmful oils, acids, gases, vapors, dust, radiation, etc.
- Use in non-stationary applications with strong mechanical oscillation and impact loads, as specified in the documentation

2.6 *Electrical connection*

Observe the applicable national accident prevention guidelines when working on live MOVIMOT[®] drive inverters (e.g. BGV A3).

Perform electrical installation according to the pertinent regulations (e.g. cable cross sections, fusing, protective conductor connection). For any additional information, refer to the applicable documentation.

For information on EMC-compliant installation – such as shielding, grounding, arrangement of filters and routing of lines – refer to the documentation. The manufacturer of the system or machine is responsible for maintaining the limits established by EMC legislation.



Protective measures and protection devices must comply with the regulations in force (e.g. EN 60204 or EN 61800-5-1).

A voltage test according to EN 61800-5-1:2007 chapter 5.2.3.2 is required for MOVIMOT[®] drives prior to startup to ensure insulation.

2.7 Safe disconnection

MOVIMOT[®] inverters meet all requirements for safe disconnection of power and electronic connections in accordance with EN 61800-5-1. All connected circuits must also satisfy the requirements for safe disconnection.

2.8 Operation

Systems with integrated MOVIMOT[®] inverters must be equipped with additional monitoring and protection devices according to the applicable safety guidelines, such as the law governing technical equipment, accident prevention regulations, etc. Additional protective measures might be necessary for applications with increased potential risk.

Do not touch live components or power connections immediately after disconnecting the MOVIMOT[®] inverter, the field distributor (if installed) or the bus module (if installed) from the supply voltage because there may still be some charged capacitors. Wait at least for 1 minute after having switched off the supply voltage.

As soon as supply voltage is present at the MOVIMOT[®] inverter, the terminal box must be closed, which means that:

- The MOVIMOT[®] inverter must be screwed on.
- The terminal box cover of the field distributor (if present) and the bus module (if present) must be bolted down.
- The connector of the hybrid cable (if installed) must be connected and screwed on.

Note: The maintenance switch of the field distributor (if installed) only disconnects the connected MOVIMOT[®] drive or motor from the power supply system. The terminals of the field distributor remain connected to the line voltage even after the maintenance switch is activated.

The fact that the status LED and other display elements are no longer illuminated does not indicate that the unit has been disconnected from the supply system and no longer carries any voltage.

Mechanical blocking or internal safety functions of the unit can cause a motor standstill. Eliminating the cause of the problem or performing a reset may result in the drive re-starting automatically. If, for safety reasons, this is not permitted for the driven machine, disconnect the unit from the supply system before correcting the error.

Caution: Danger of burns: The surface temperature of the MOVIMOT[®] drive and of external options, e.g. the heat sink of the braking resistor, can exceed 60 °C during operation!



3 Type Designations

3.1 Sample motor nameplate

SEW -EURODRIVE		Bruchsal / Germany		☺	☺
Typ	KA77 DT90L4/BMG/MM15/MLU	3 ~	IEC 34		
Nr.	3009818304.0001.99	IM	B3		
KW	1,5 / 50 HZ	cos	0,99		
○50Hz	V 380-500	A	3,50		○
60Hz	V 380-500	A	3,50		
r/min	22/1400	IP	54 KI	F	
Bremse	V 230	Nm 20	Gleichrichter		
kg 73	Ma 665	Nm	i	64,75 :1	
Schmierstoff		Made in Germany 184103 3.14			

1996182283

KA 77 DT 90L4 BMG/MM15/MLU

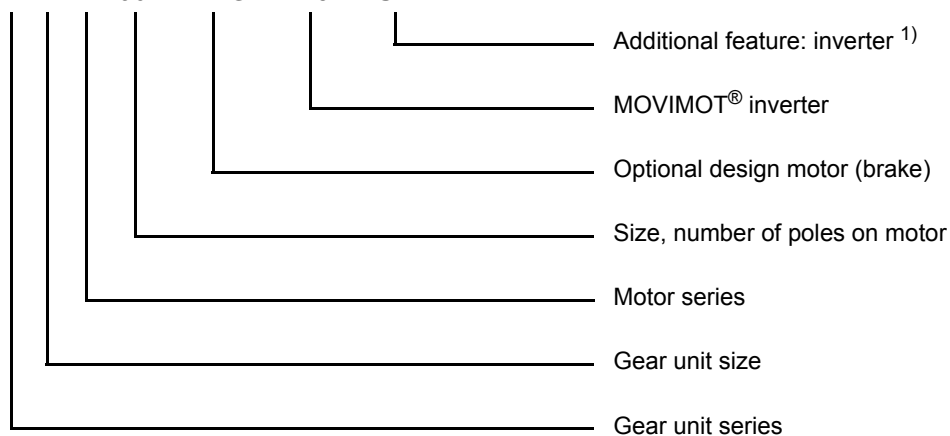

1) Nameplate only displays options installed at the factory.



3.2 Sample inverter nameplate





18 12 - A - - 10 10 12

Status: 10 12 -- A -- -- 10 10 12 02 / 08 444



6241805 0099377

SEW EURODRIVE D-76646 Bruchsal Made in Germany MOVIMOT Antriebsumrichter Drive Inverter	Typ	MM15D-503-00	CE  CH01 N2936 	
	Sach.Nr.	18215033		Serien Nr.
	Eingang / Input			Ausgang / Output
	U=	3x380...500V AC	U=	3x0V...U _{Input}
f=	50...60Hz	f=	2...120Hz	
I=	3.5AAC	I=	4.0AAC	
T=	-30...40C			
P-Motor	1.5kW / 2.0HP			
P-Motor (S3/25%)	2.2kW / 3.3HP			

Use 60/75°C copper wire only. Tighten terminals to 13,3in. - lbs.(1.5 Nm)
Suitable for use on a circuit capable of delivering not more than 5000ms

1957927307

MM 15 D – 503 – 00

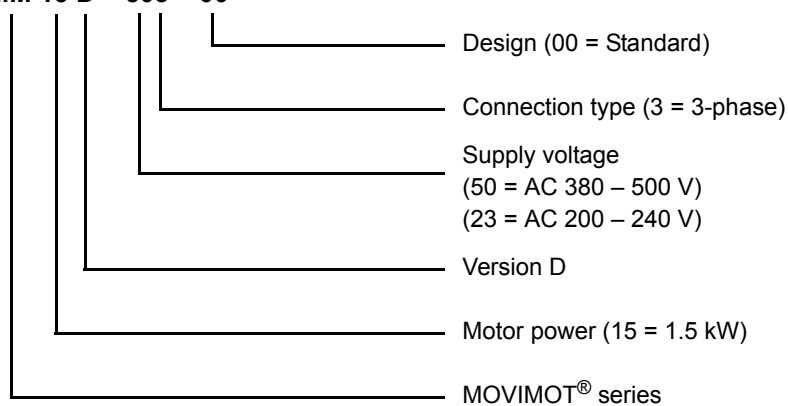

3.3 Unit identification

The unit identification [1] on the top of the MOVIMOT® inverter provides information about the inverter type [2], inverter part number [3], unit power [4].

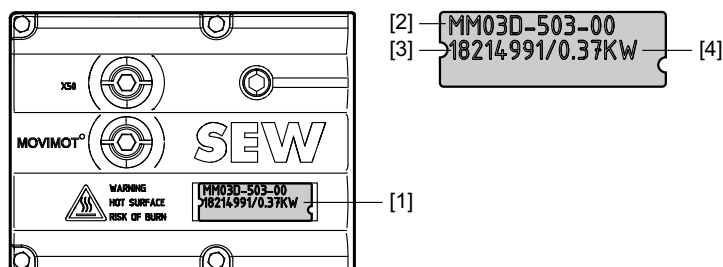

457916555



Type Designations

"Mounting close to the motor" design

3.4 "Mounting close to the motor" design

The following illustration shows an example of the MOVIMOT® inverter mounted close to the motor with corresponding nameplate and type designation:

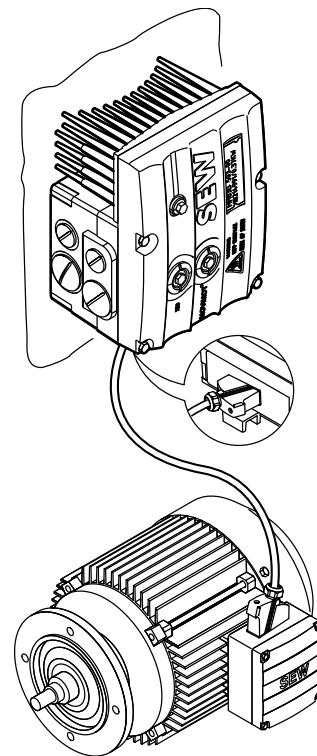

457921547

MM15D-503-00/0/P21A/RO1A/APG4

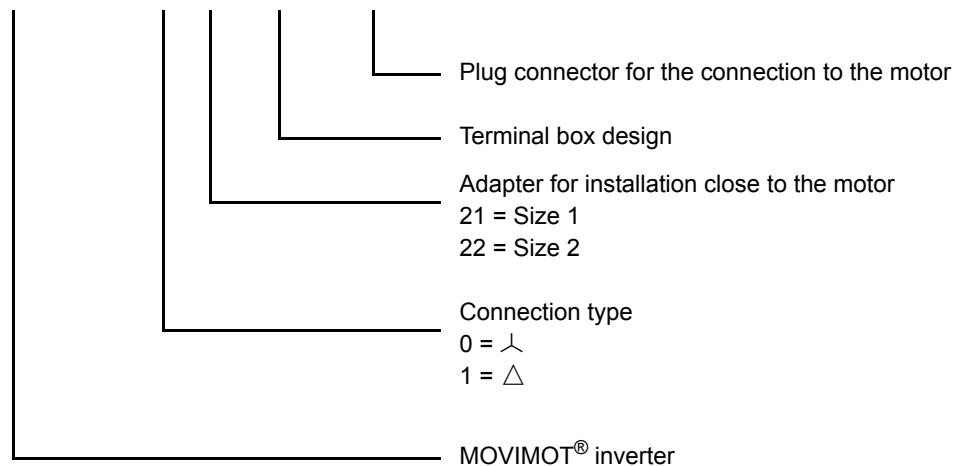



4 Mechanical Installation

4.1 MOVIMOT® gearmotor

4.1.1 Before you start

Only install the MOVIMOT® drive if:

- The entries on the nameplate of the drive match the voltage supply system.
- The drive is undamaged (no damage caused by transportation or storage).
- You are certain that the following requirements have been fulfilled:
 - Ambient temperature corresponds to the specifications in chapter "Technical Data" of the operating instructions. Note that the temperature range of the gear unit may also be restricted (see gear unit operating instructions).
 - No oil, acid, gas, vapors, radiation, etc.

Installation tolerances

The following tables shows the permitted tolerances of the shaft ends and flanges of the MOVIMOT® drive.

Shaft end	Flanges
Diameter tolerance according to EN 50347 <ul style="list-style-type: none"> • ISO j6 with $\varnothing \leq 26$ mm • ISO k6 with $\varnothing \leq 38$ mm up to ≤ 48 mm • ISO m6 at $\varnothing > 55$ mm • Center bore in accordance with DIN 332, shape DR.. 	Centering shoulder tolerance in accordance with EN 50347 <ul style="list-style-type: none"> • ISO j6 with $\varnothing \leq 250$ mm • ISO h6 with $\varnothing > 300$ mm



4.1.2 Installing MOVIMOT®

Observe the following notes for mounting the MOVIMOT® drive:

- Install/mount the MOVIMOT® drive only in the mounting position specified on the motor nameplate on a level, vibration-free, and torsionally rigid support structure.
- Clean the output shafts thoroughly to ensure they are free of anti-corrosion agents (use a commercially available solvent). Do not allow the solvent to penetrate the bearings and shaft seals – this could damage the material.
- Carefully align the MOVIMOT® inverter and the motor, to avoid placing any unacceptable strain on the motor shafts (observe permissible overhung load and axial load data!).
- Do not butt or hammer the shaft end.
- Use an appropriate cover to prevent objects or fluids from entering motors in vertical mounting positions.
- Ensure there is sufficient clearance around the unit to allow for adequate cooling. Furthermore, the unit must be positioned in such a way that it does not reuse the air warmed by other devices.
- Balance components for subsequent mounting on the shaft with a half key (output shafts are balanced with a half key).
- Existing condensation drain holes must be sealed with plastic plugs. They must not be opened unless needed.
- Open condensation drain holes are not permitted. If condensation drain holes are open, higher enclosures are no longer possible.

	STOP
	<p>The degree of protection specified in the technical data only applies if the MOVIMOT® inverter is properly installed.</p> <p>When the MOVIMOT® inverter is removed from the connection box, it might be damaged by humidity or dust.</p> <ul style="list-style-type: none"> • Protect the MOVIMOT® inverter when it is removed from the connection box.

4.1.3 Installation in damp locations or in the open

Observe the following notes for mounting the MOVIMOT® drive in damp areas or in the open:

- Use suitable cable glands for the supply leads (use reducing adapters if necessary).
- Coat the threads of cable glands and filler plugs with sealing compound and tighten them well; then coat them again.
- Seal the cable entries well.
- Clean the sealing faces of the MOVIMOT® inverter well before re-assembly.
- If the corrosion protection coating is damaged, restore the coating.
- Check enclosure according to nameplate.



4.2 Installing the MOVIMOT[®] inverter close to the motor

The following figure shows the mounting dimensions for installing the MOVIMOT[®] inverter close to the motor:

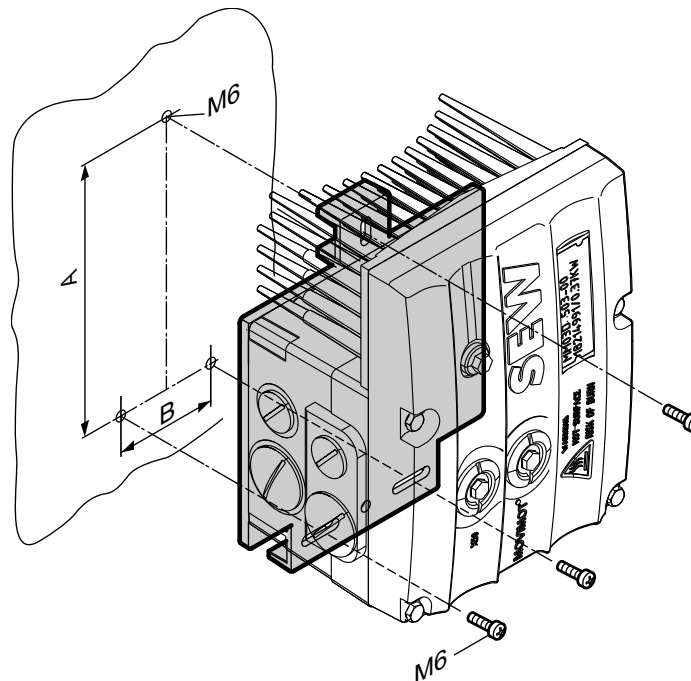

458277771

	A	B
MM03D503-00 – MM15D-503-00 MM03D233-00 – MM07D-233-00	140 mm	65 mm
MM22D503-00 – MM40D-503-00 MM11D233-00 – MM22D-233-00	170 mm	65 mm



4.3 Tightening torques

4.3.1 MOVIMOT® inverter

Tighten the screws on the MOVIMOT® inverter using 3.0 Nm (27 lb.in) working diagonally across.

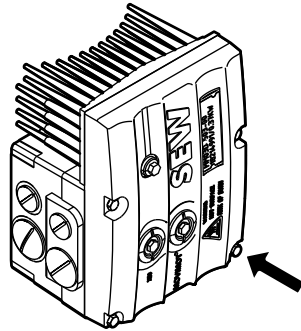

458577931

4.3.2 Screw plugs

Tighten screw plugs of potentiometer f1 and connection X50 using 2.5 Nm (22 lb.in).

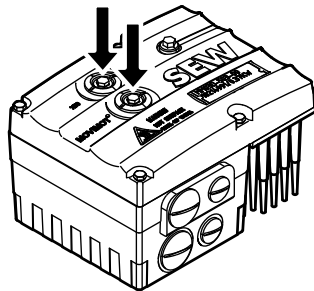

458570379

4.3.3 Cable glands

It is essential to observe the manufacturer's specifications for the cable glands.



4.3.4 Screw plugs for cable entries

Tighten screw plugs with 2.5 Nm (22 lb.in).

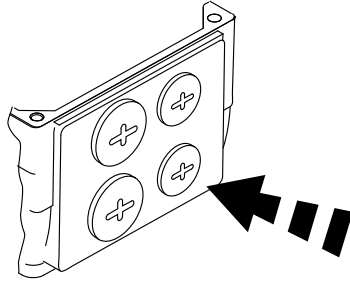

322777611

4.3.5 Tightening torques for terminals

Use the following tightening torques for terminals during installation:

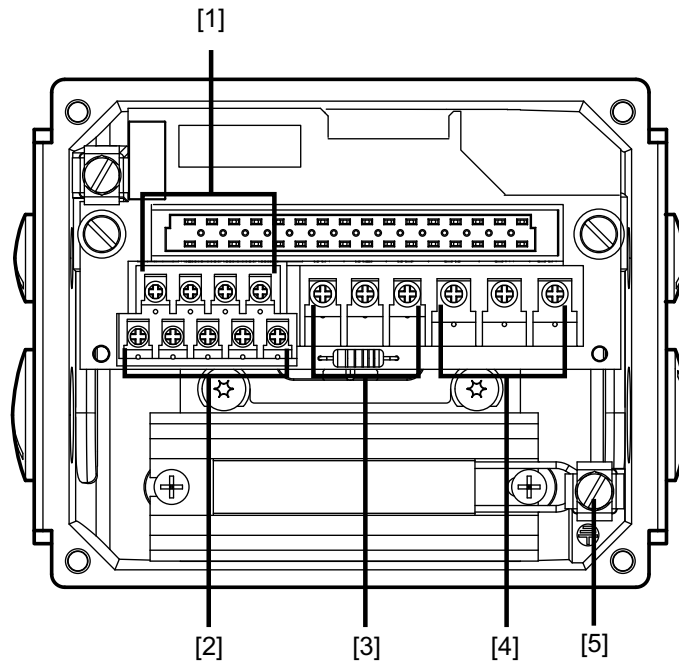

1999952907

- [1] 0.5 – 0.7 Nm (4 – 6 lb.in)
- [2] 0.5 – 0.7 Nm (4 – 6 lb.in)
- [3] 0.8 – 1.5 Nm (7 – 10 lb.in)
- [4] 1.2 – 1.6 Nm (11 – 14 lb.in)
- [5] 2.0 – 2.4 Nm (18 – 21 lb.in)



5 Electrical Installation

5.1 Installation instructions

5.1.1 Connecting supply system leads

- The rated voltage and frequency of the MOVIMOT[®] inverter must correspond to the data for the power supply system.
- Cable cross section: according to input current I_{line} for rated power (see chapter "Technical Data" in the operating instructions).
- Permitted cable cross section of MOVIMOT[®] terminals (does not apply to field distributors):

Field wiring power terminals			
1.0 mm ² - 4.0 mm ² (2 x 4.0 mm ²)			
AWG17 – AWG10 (2 x AWG10)			
Control terminals			
Single-wire conductor (bare wire)	Flexible conductor (bare litz wire)	Conductor with Conductor end sleeve without insulating shrouds	Conductor with Conductor end sleeve with insulating shrouds
0.5 mm ² – 1.0 mm ²			0.5 mm ² – 0.75 mm ²
AWG20 – AWG17			AWG20 – AWG19
Only connect single-wire conductors or flexible conductors with or without conductor end sleeve (DIN 46228 part 1, material E-CU)			

- Permitted length of the conductor end sleeve: At least 8 mm
- Use conductor end sleeves without insulating shrouds (DIN 46228 part 1, material E-CU).
- Install line fuses at the beginning of the power supply cable behind supply bus junction (see the section "Connection of MOVIMOT[®] basic unit"). Use only D, D0 or NH melting fuses or circuit breakers for F11/F12/F13. Select the fuse size according to the cable cross section.
- SEW recommends using earth-leakage monitors with pulse code measuring in voltage supply systems with a non-earthed star point (IT systems). Using such devices prevents the earth-leakage monitor mis-tripping due to the ground capacitance of the inverter.



5.1.2 Earth-leakage circuit breakers

- Do not use a conventional earth-leakage circuit breaker as a protective device. Universal current-sensitive earth leakage circuit-breakers (tripping current 300 mA) are permitted as a protective device. During normal operation of MOVIMOT[®] inverter, earth-leakage currents of > 3.5 mA can occur.
- SEW-EURODRIVE recommends that you do not use earth-leakage circuit breakers. However, if an earth-leakage circuit breaker is stipulated for direct or indirect protection against contact, observe the following note in accordance with EN 61800-5-1:

	⚠ WARNING
	<p>Wrong type of earth-leakage circuit breaker installed.</p> <p>Severe or fatal injuries.</p> <p>MOVIMOT[®] can cause direct current in the protective earth. In cases where an earth-leakage circuit breaker is used for protection against direct or indirect contact, only install a type B earth-leakage circuit breaker on the power supply end of the MOVIMOT[®] inverter.</p>

5.1.3 Input contactor

- Only use a contactor of utilization category AC3 (EN 60947-4-1) as an input contactor.

	NOTICE
	<ul style="list-style-type: none"> • Do not use the K11 input contactor (see wiring diagram (page 20)) for jog mode, but only for switching the inverter on and off. For jog mode, use the the commands "CW / Stop" or "CCW / Stop". • Observe a minimum switch-off time of 2 s for the supply system contactor K11.

5.1.4 EMC-compliant installation

	⚠ WARNING
	<p>This drive system is not designed for operation on a public low voltage supply system that supplies residential areas.</p>

With respect to the EMC regulation, frequency inverters cannot be operated as stand-alone units. Regarding EMC, they can only be evaluated when they are integrated in a drive system. Conformity is declared for a described, CE-typical drive system. The operating instructions contain further information.

	INFORMATION
	<ul style="list-style-type: none"> • This is a product with restricted availability in accordance with IEC 61800-3. It may cause EMC interference. In this case, it is recommended for the operator to carry out suitable measures. • For detailed information on EMC compliant installation, refer to the publication "Electromagnetic Compatibility in Drive Engineering" from SEW-EURODRIVE.



5.1.5 Notes on PE connection

	! DANGER
	<p>Incorrect connection of PE.</p> <p>Death, severe injuries or damage to property from electric shock.</p> <ul style="list-style-type: none"> The permitted tightening torque for the screw fitting is 2.0 - 2.4 Nm (18 - 21 lb.in). Observe the following notes regarding PE connection.

Prohibited assembly sequence	Recommendation: Assembly with forked cable lug Permitted for all cross sections	Assembly with thick solid wire Permitted for cross sections up to max. 2.5 mm ²
<p>323042443</p>	<p>323034251</p>	<p>323038347</p>

[1] Forked cable lug suitable for M5 PE screws

Earth-leakage currents ≥ 3.5 mA may occur during normal operation. To meet the requirements of EN 61800-5-1 observe the following note:

- Route a second PE conductor with the cross section of the supply system lead in parallel to the protective earth via separate terminals or use a copper protective earth conductor with a cross section of 10 mm².



5.1.6 Installation altitude above 1000 m above sea level

MOVIMOT® drives with line voltages of 200 to 240 V or 380 to 500 V, can be used in altitudes of 1000 m and up to a maximum of 4000 m above sea level under the following conditions.¹⁾

- The rated continuous power is reduced based on the reduced cooling above 1000 m (see "Technical Data" chapter in the operating instructions).
- Above 2000 m above sea level, the air and creeping distances are only sufficient for overvoltage class 2. If the installation requires overvoltage class 3, you will have to install additional external overvoltage protection to limit overvoltage peaks to 2.5 kV phase-to-phase and phase-to-ground.
- If safe electrical disconnection is required, it must be implemented outside the device at altitudes of 2000 msl (safe electrical disconnection in accordance with EN 61800-5-1).
- In installation altitudes between 2000 m to 4000 msl, the permitted rated power supply voltages are reduced as follows:
 - By 6 V per 100 m for MM..D-503-00
 - By 3 V per 100 m for MM..D-233-00

5.1.7 Connecting 24 V supply

- Power the MOVIMOT® inverter either via an external 24 V supply or the MLU..A or MLG..A options.

5.1.8 Binary control

- Connect the required control leads.
- Use shielded cables as control cables and route them separately from supply system cables.

5.1.9 UL-compliant installation

- Use only copper cables for temperature range 60/75 °C as connection lead.
- The permitted tightening torques for MOVIMOT® power terminals are: 1.5 Nm (13 lb.in).
- The permitted supply system voltage is 500 V (400/500 V inverter) or 240 V (230 V inverter). Information about the max. permitted short-circuit currents of the supply system and the fuse is listed on the nameplate of the MOVIMOT® inverter.

	INFORMATION
	<ul style="list-style-type: none"> • Only use certified units with a limited output voltage ($V_{max} = DC 30 V$) and limited power ($P \leq 100 VA$) as an external DC 24 V voltage source. • The UL certification only applies to the operation on voltage supply systems with voltages to ground of max. 300 V. The UL-certification does not apply to the operation on voltage supply systems with a non-grounded star point (IT systems).

1) The maximum altitude is limited by creeping distances and flameproof components, such as electrolytic capacitors.



5.2 Connection of MOVIMOT®

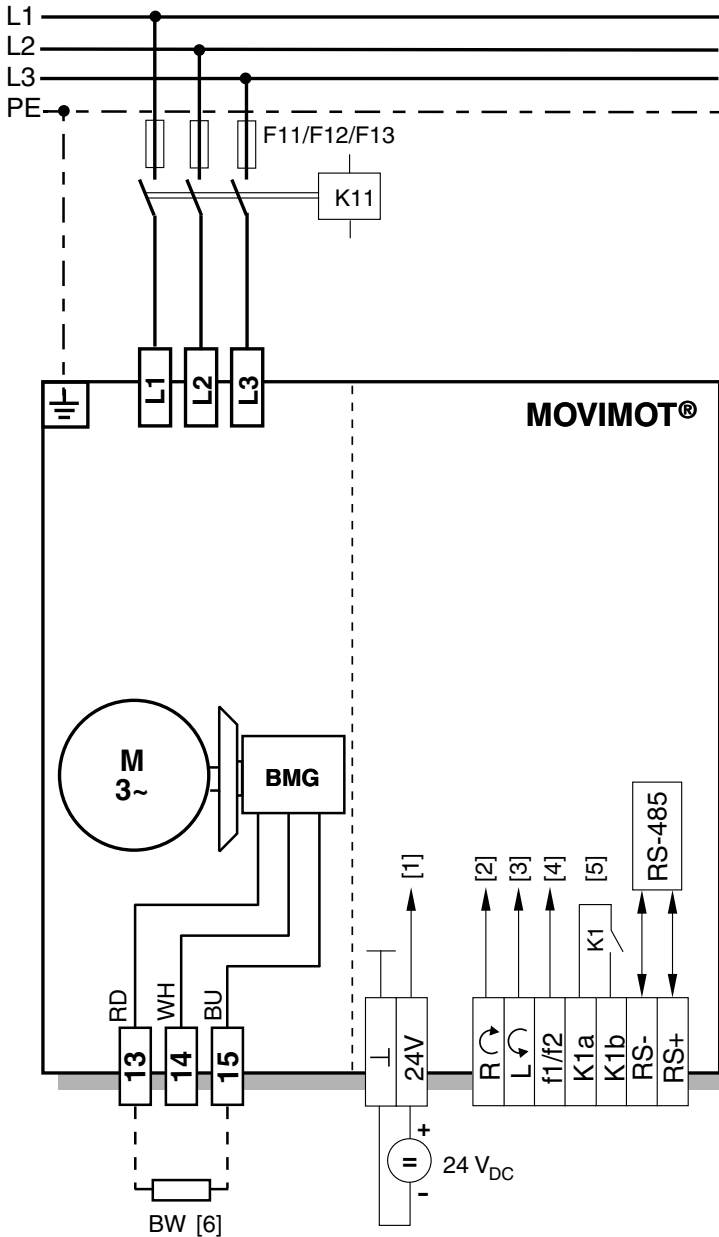

Functions of the CW/Stop + CCW/Stop terminals for binary control:

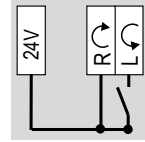

Direction of rotation
CW active

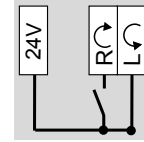

Direction of rotation
CCW active

Functions of terminals f1/f2:

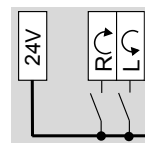

Setpoint f1
active

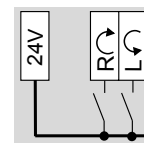

Setpoint f2 active

Functions of the CW/Stop + CCW/Stop terminals for control via RS-485 interface / fieldbus:

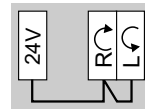

Both directions of rotation
are enabled

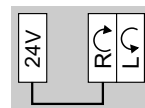

Only **CW** direction
is enabled
Pre-selected setpoints for CCW
rotation result in standstill of drive

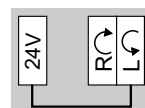

Only **CCW** operation
is enabled
Setpoint specifications for CW
rotation result in standstill of drive

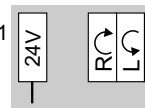

Drive is inhibited or is being
brought to a stop

2000232971

- [1] DC 24 V supply (external or MLU..A/MLG..A options)
- [2] CW / stop
- [3] CCW / stop
- [4] Setpoint changeover f1/f2
- [5] Ready signal (contact closed = ready for operation)
- [6] BW.. braking resistor
(only for MOVIMOT® drives without mechanical brake)



5.3 Connection between MOVIMOT® and motor when mounted close to the motor

If the MOVIMOT® inverter is mounted close to the motor, the connection to the motor is realized with a pre-fabricated cable (hybrid cable).

Use only hybrid cables from SEW-EURODRIVE to connect the MOVIMOT® inverter with the motor.

The following designs are possible on the MOVIMOT® side:

- A: MM../P2.A/RO.A/APG4
- B: MM../P2.A/RE.A/ALA4

The APG4 design results in the following connection options to the motor, depending upon the hybrid cable used:

Design	A1	A2	A3	A4
MOVIMOT®	APG4	APG4	APG4	APG4
Motor	Cable gland/terminals	ASB4	APG4	IS
Hybrid cables	0 186 742 3	0 593 076 6	0 186 741 5	0 816 325 1 0 816 326 X 0 593 278 5 0 593 755 8

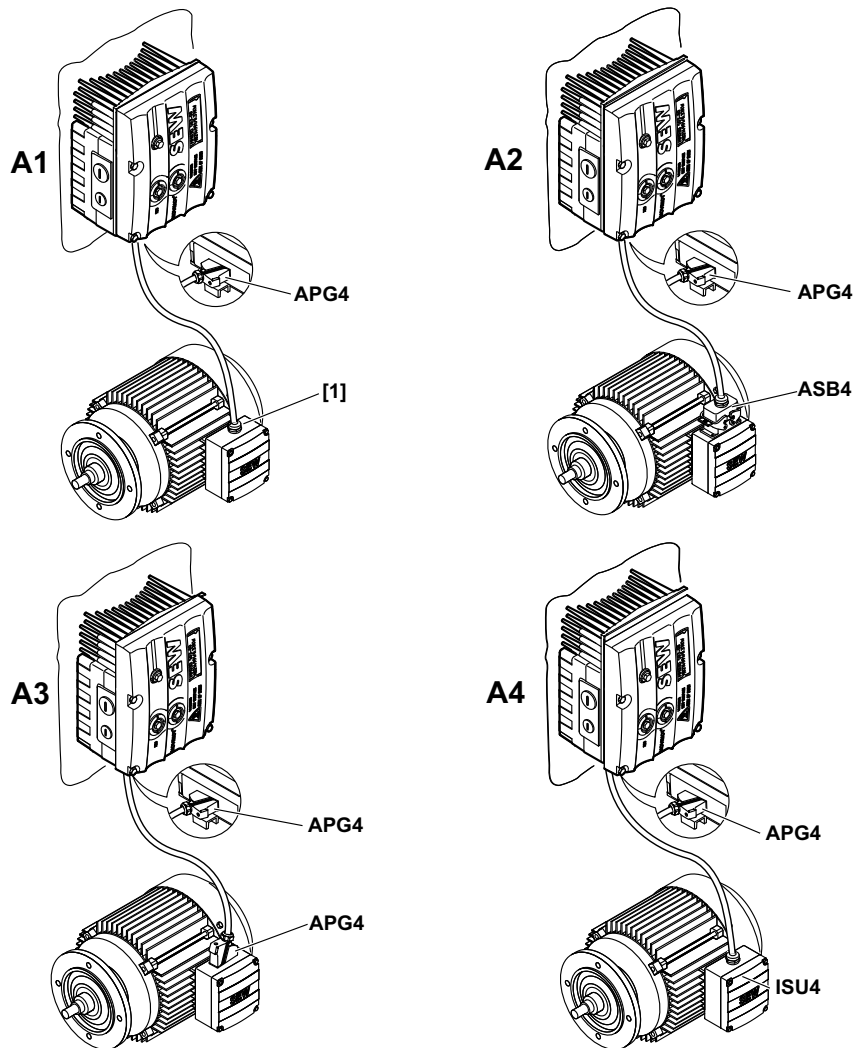

[1] Connection via terminals

2000749067



Electrical Installation

Connection between MOVIMOT® and motor when mounted close to the

The APG4 design results in the following connection options to the motor, dependent upon the hybrid cable used:

Type	B1	B2
MOVIMOT®	ALA4	ALA4
Motor	Cable gland/terminals	ASB4
Hybrid cables	0 817 948 4	0 816 208 5

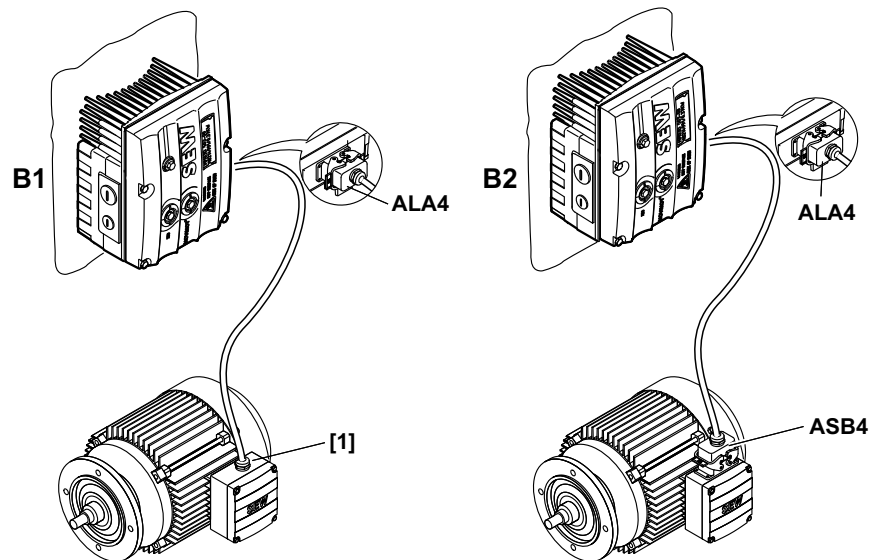

[1] Connection via terminals

2000812811



5.3.1 Hybrid cable connection

The following tables shows the conductor assignment in hybrid cables with part number 0 186 742 3 and 0 817 948 4 and the corresponding motor terminals of the DT/DV motor:

Motor terminal of DT/DV motors	Wire color/hybrid cable designation
U1	Black/U1
V1	Black/V1
W1	Black/W1
4a	Red/13
3a	White/14
5a	Blue/15
1a	Black/1
2a	Black/2
PE connection	Green/yellow + shield end (internal shield)

The following figure shows the connection of the hybrid cable to the terminal box of the DT/DV motor.

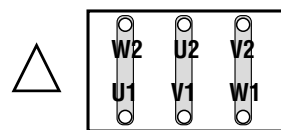
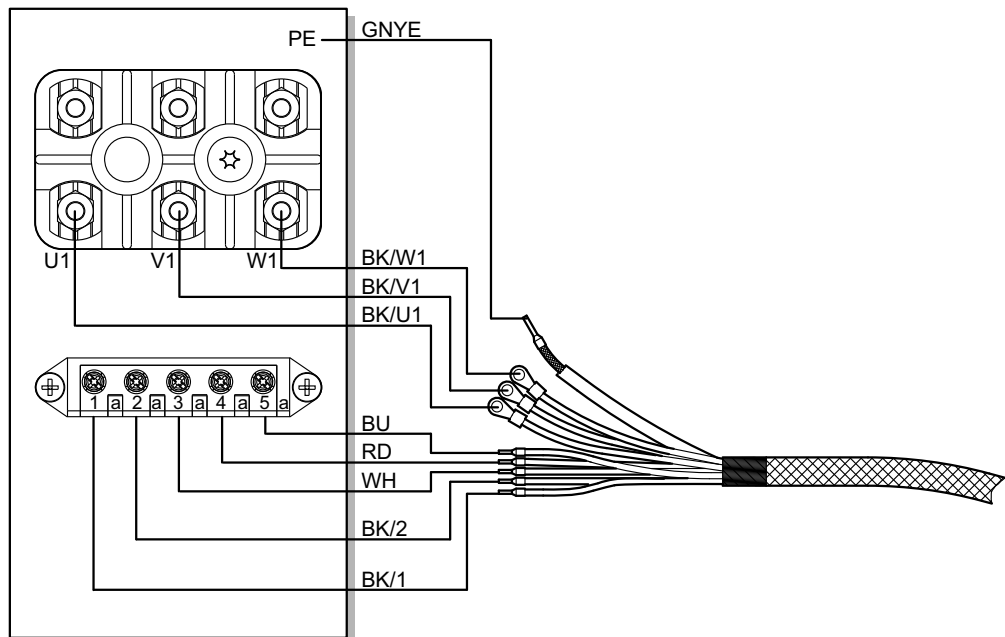



2000865419



6 Startup

6.1 Important notes on startup

	<p>⚠ DANGER</p> <p>Before removing / fitting the MOVIMOT[®] inverter, you must disconnect it from the supply system. Dangerous voltages may still be present for up to one minute after disconnection from the power supply.</p> <p>Severe or fatal injuries from electric shock.</p> <ul style="list-style-type: none"> • Disconnect the MOVIMOT[®] drive from the power supply using an appropriate external disconnecting device and secure it against unintentional reconnection to the voltage supply. • Then wait at least for 1 minute.
	<p>⚠ WARNING</p> <p>The surfaces of MOVIMOT[®] and external options, e.g. braking resistor (especially the heat sink), can become very hot during operation.</p> <p>Danger of burns.</p> <ul style="list-style-type: none"> • Do not touch the MOVIMOT[®] drive and external options until they have cooled down sufficiently.
	<p>INFORMATION</p> <ul style="list-style-type: none"> • Remove paint protection cap from the status LED before startup. • Remove paint protection film from the nameplates before startup. • Check that all protective covers are installed correctly. • Observe a minimum switch-off time of 2 seconds for the mains contactor K11.

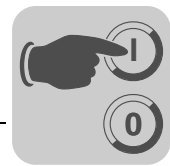

6.2 Description of the controls

6.2.1 Setpoint potentiometer f1

Depending on the operating mode of the MOVIMOT® inverter, the potentiometer f1 has different functions:

- Binary control: Setting setpoint f1
(selected via terminal f1/f2 = "0")
- Control via RS-485: Setting maximum frequency f_{max}

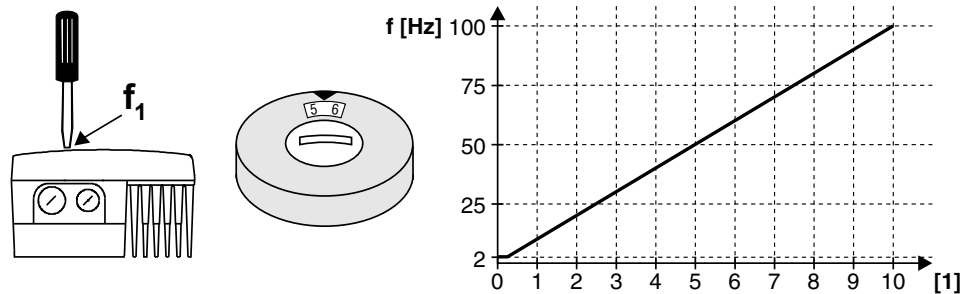

[1] Potentiometer setting

329413003



NOTICE

The enclosure specified in section Technical Data only applies if the screw plugs of the setpoint potentiometer and the X50 diagnostic interface are installed correctly.

Missing or incorrectly installed screw plugs can cause damage to the MOVIMOT® inverter.

- Make sure the screw plug of the setpoint potentiometer f1 has a seal and screw it in.

6.2.2 Switch f2

Depending on the operating mode of the MOVIMOT® inverter, switch f2 has different functions:

- Binary control: Setting setpoint f2
(selected via terminal f1/f2 = "1")
- Control via RS-485: Setting minimum frequency f_{min}



Switch f2											
Detent setting	0	1	2	3	4	5	6	7	8	9	10
Setpoint f2 [Hz]	5	7	10	15	20	25	35	50	60	70	100
Minimum frequency [Hz]	2	5	7	10	12	15	20	25	30	35	40

6.2.3 Switch t1

Use switch t1 to set the acceleration of the MOVIMOT® drive.

The ramp times are based on a setpoint step change of 1500 rpm (50 Hz).



Switch t1											
Detent setting	0	1	2	3	4	5	6	7	8	9	10
Ramp time t1 [s]	0,1	0,2	0,3	0,5	0,7	1	2	3	5	7	10



6.2.4 DIP switches S1 and S2

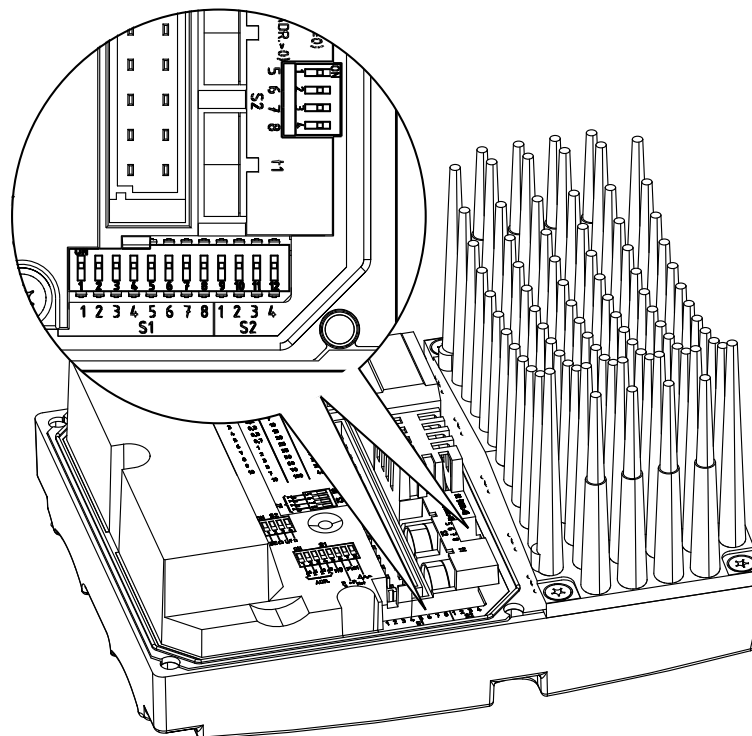

626648587

DIP switch S1:

S1 Meaning	1	2	3	4	5 Motor protection	6 Motor Power rating	7 PWM Frequency	8 No-load damping
	Binary encoding RS-485 unit address							
	2 ⁰	2 ¹	2 ²	2 ³				
ON	1	1	1	1	Off	Motor one size smaller	Variable (16, 8, 4 kHz)	On
OFF	0	0	0	0	On	Motor adjusted	4 kHz	Off

DIP switch S2:

S2 Meaning	1	2	3	4	Binary encoding additional functions			
	Motor type	Release brake without enable	Operating mode	Speed monitoring	2 ⁰	2 ¹	2 ²	2 ³
	ON	SEW DZ motor ¹⁾	On	V/f	On	1	1	1
OFF	IEC motor	Off	VFC	Off	0	0	0	0

1) available only in Brazil



NOTICE

Set the DIP switches using suitable tools, e.g. a flat tip screwdriver with a blade width ≤ 3 mm.

The force used for setting the DIP switches must not exceed 5 N.

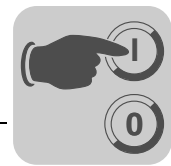

6.3 Description of the DIP switches S1

6.3.1 DIP switches S1/1 – S1/4

Selecting the RS-485 address of MOVIMOT® via binary coding

Decimal Address	0	1	2	3	4	5	6	7	8	9	10	11	12	13	14	15
S1/1	-	X	-	X	-	X	-	X	-	X	-	X	-	X	-	X
S1/2	-	-	X	X	-	-	X	X	-	-	X	X	-	-	X	X
S1/3	-	-	-	-	X	X	X	X	-	-	-	-	X	X	X	X
S1/4	-	-	-	-	-	-	-	-	X	X	X	X	X	X	X	X

X = ON
- = OFF

Set the following addresses depending on how the MOVIMOT® inverter is controlled:

Control	RS-485 address
Binary control	0
Via keypad (MLG..A, MBG..A)	1
Via fieldbus interface (MF..)	1
Via MOVIFIT® MC (MTM..)	1
Via intelligent fieldbus interface (MQ..)	1 to 15
Via RS-485 master	1 to 15

6.3.2 DIP switch S1/5

Motor protection switched on/off

When MOVIMOT® is installed close to the motor, the motor protection function must be deactivated.

To ensure that the motor is protected all the same, a TH (bimetallic thermostat) must be installed. The TH opens the sensor circuit when the rated response temperature is reached (see field distributor manual).



6.3.3 DIP switch S1/6

Lower motor power rating

- When activated, this DIP switch enables MOVIMOT® to be assigned to a motor with a lower power rating. The rated unit power is not affected.
- When a motor with a lower power rating is used, the overload capacity of the drive can be increased because, from the perspective of the motor, MOVIMOT® is one power rating too big. A higher current can be provided briefly, leading to higher torque ratings.
- The aim of this switch S1/6 is to achieve short-term utilization of the motor's peak torque. The unit's current limit remains the same regardless of the switch setting. The motor protection function is adjusted depending on the switch setting.
- Stall protection for the motor is not possible in this operating mode (S1/6 = "ON").

MOVIMOT® inverter MM..D-503-00	Assigned motor 230 / 400 V, 50 Hz 266 / 460 V, 60 Hz			
	S1/6 = OFF		S1/6 = ON	
380 – 500 V				
MM03D-503-00	DT71D4	DR63L4 ¹⁾	DR63L4 ¹⁾	–
MM05D-503-00	DT80K4	DT71D4	DT71D4	DFR63L4 ¹⁾
MM07D-503-00	DT80N4	DT80K4	DT80K4	DT71D4
MM11D-503-00	DT90S4	DT80N4	DT80N4	DT80K4
MM15D-503-00	DT90L4	DT90S4	DT90S4	DT80N4
MM22D-503-00	DV100M4	DT90L4	DT90L4	DT90S4
MM30D-503-00	DV100L4	DV100M4	DV100M4	DT90L4
MM40D-503-00	–	DV100L4	DV100L4	DV100M4

MOVIMOT® inverter MM..D-233-00	Assigned motor 230 / 460 V, 60 Hz /	
	S1/6 = OFF	S1/6 = ON
200 – 240 V		
MM03D-233-00	DT71D4	DR63L4 ¹⁾
MM05D-233-00	DT80K4	DT71D4
MM07D-233-00	DT80N4	DT80K4
MM11D-233-00	DT90S4	DT80N4
MM15D-233-00	DT90L4	DT90S4
MM22D-233-00	DV100M4	DT90L4

1) Only possible with installation close to the motor

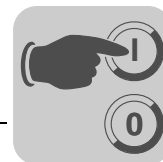

6.3.4 DIP switch S1/7

Setting the maximum PWM- frequency

- When DIP switch S1/7 is set to "OFF", the MOVIMOT® unit operates with 4 kHz PWM frequency.
- When DIP switch S1/7 is set to "ON", the MOVIMOT® unit operates with a 16 kHz PWM frequency (low noise) and switches back in steps to lower switching frequencies depending on the heat sink temperature and the inverter load.

6.3.5 DIP switch S1/8

No load vibration damping (S1/8 = "ON")

When setting DIP switch S1/8, this function reduces resonance during no-load operation.

6.4 Description of DIP switches S2

6.4.1 DIP switch S2/1

Motor type

- For IEC and NEMA motors, DIP switch S2/1 must always be set to "OFF".
- For DZ motors with nominal voltages of 220/380 V, 60 Hz (only available in Brazil), the DIP switch must always be set to "ON".

6.4.2 DIP switch S2/2



Brake release without enable

When switch S2/2 is set to "ON", it is possible to release the brake even if there is no drive enable.

This function is not available in hoist operation.

Binary control functions

In binary control, the brake can be released by setting the signal at terminal f1/f2 subject to the following preconditions:

Terminal status		f1/f2	Enable status	Fault status	Brake function
R 	L 				
"1"	"0"	"0"	Unit enabled	No unit fault	Brake is controlled by MOVIMOT®, setpoint f1
"0"	"1"	"0"	Unit enabled	No unit fault	Brake is controlled by MOVIMOT®, setpoint f1
"1"	"0"	"1"	Unit enabled	No unit fault	Brake is controlled by MOVIMOT®, Setpoint f2
"0"	"1"	"1"	Unit enabled	No unit fault	Brake is controlled by MOVIMOT®, Setpoint f2
"1"	"1"	"0"	Unit not enabled	No unit error	Brake applied
"0"	"0"	"0"	Unit not enabled	No unit error	Brake applied
"1"	"1"	"1"	Unit not enabled	No unit error	Brake applied
"0"	"0"	"1"	Unit not enabled	No unit error	Brake is released for manual movement
All states possible			Unit not enabled	Unit fault	Brake applied



Startup
Description of DIP switches S2

RS-485 control functions

In RS-485 control, the brake is released via the control word:

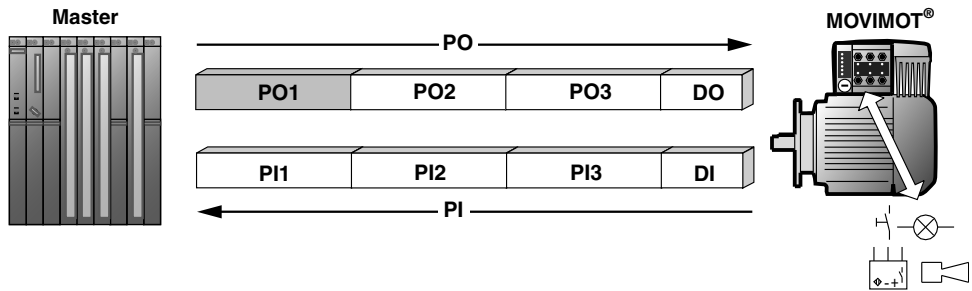

329547915

- PO = Process output data
- PO1 = Control word**
- PO2 = Speed [%]
- PO3 = Ramp
- DO = Digital outputs
- PI = Process input data
- PI1 = Status word 1
- PI2 = Output current
- PI3 = Status word 2
- DI = Digital inputs

By setting bit 8 in the control word, the brake can be released if the following conditions are met:

								Basic control block							
15	14	13	12	11	10	9	8	7	6	5	4	3	2	1	0

Control word						
not assigned ¹⁾	Bit "9"	Bit "8"	Not assigned ¹⁾	"1" = Reset	Not assigned ¹⁾	"1 1 0" = Enable otherwise stop

Virtual terminals for releasing the brake without drive enable

Virtual terminal for applying brake and inhibiting output stage "Stop" control command

1) Recommendation for all bits that are not assigned = "0"

Enable status	Error status	Status of bit 8 in control word	Brake function
Unit enabled	No unit error / no communication timeout	"0"	Brake is controlled by MOVIMOT®
Unit enabled	No unit error / no communication timeout	"1"	Brake is controlled by MOVIMOT®
Unit not enabled	No unit error / no communication timeout	"0"	Brake applied
Unit not enabled	No unit error / no communication timeout	"1"	Brake is released for manual movement
Unit not enabled	Unit error / communication timeout	"1" or "0"	Brake applied

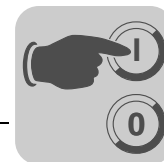

Setpoint selection for binary control

Setpoint selection in binary control depending on the state of terminal f1/f2:

Enable status	Terminal f1/f2	Active setpoint
Unit enabled	Terminal f1/f2 = "0"	Setpoint potentiometer f1 active
Unit enabled	Terminal f1/f2 = "1"	Setpoint potentiometer f2 active

Behavior if unit not ready

If the unit is not ready, the brake is always applied irrespective of the setting of terminal f1/f2 or bit 8 in the control word.

LED display

The status LED flashes periodically at a fast rate ($t_{on} : t_{off} = 100 \text{ ms} : 300 \text{ ms}$) if the brake has been released for manual movement. This applies both for binary control and for control via RS-485.

6.4.3 DIP switch S2/3

Operating mode

- DIP switch S2/3 = "OFF": VFC operation for 4-pole motors
- DIP switch S2/3 = "ON": V/f operation reserved for special cases

6.4.4 DIP switch S2/4

Speed monitoring

- Speed monitoring (S2/4 = "ON") protects the drive when it is blocked.
- If the drive is operated at the current limit for longer than 1 second when speed monitoring is active (S2/4 = "ON"), the MOVIMOT® inverter trips the speed monitoring. The status LED of the MOVIMOT® inverter signals the error by slowly flashing red ($t_{on} : t_{off} = 600 \text{ ms} : 600 \text{ ms}$, fault code 08). This error only occurs when the current limit has been reached for the duration of the deceleration time.

6.4.5 DIP switches S2/5 – S2/8

Additional functions

- The binary coding of the DIP switches S2/5 - S2/8 allows for the activation of additional functions.
- Proceed as follows to activate possible additional functions:

Decimal Value	0	1	2	3	4	5	6	7	8	9	10	11	12	13	14	15
S2/5	-	X	-	X	-	X	-	X	-	X	-	X	-	X	-	X
S2/6	-	-	X	X	-	-	X	X	-	-	X	X	-	-	X	X
S2/7	-	-	-	-	X	X	X	X	-	-	-	-	X	X	X	X
S2/8	-	-	-	-	-	-	-	-	X	X	X	X	X	X	X	X

X = ON
- = OFF

- You find an overview and a description of the additional functions in the detailed operating instructions.



6.5 Startup with binary control



⚠ DANGER

When working on the unit, dangerous voltage levels may still be present up to one minute after the mains is disconnected.

Severe or fatal injuries from electric shock.

- Disconnect the MOVIMOT® drive from the power supply using an appropriate external disconnecting device and secure it against unintentional reconnection to the voltage supply.
- Then wait at least for 1 minute.

1. Check the connection of the MOVIMOT® inverter.
See section "Electrical Installation".

2. Make sure that the DIP switches S1/1 – S1/4 are set to "OFF" (address = 0).
This means MOVIMOT® is controlled binary via terminals.

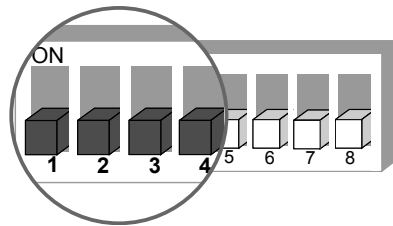

337484811

3. Set the first speed at the setpoint potentiometer f1 (active when terminals f1/f2 = "0")
(factory setting: about 1500 rpm (50 Hz)).

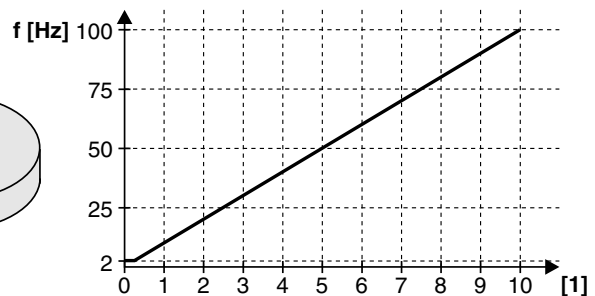
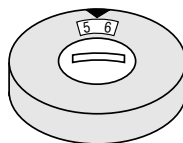
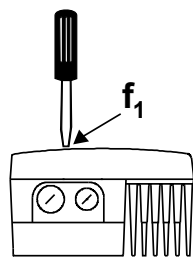

329413003

[1] Potentiometer setting

4. Make sure the screw plug of the setpoint potentiometer f1 has a seal and screw it in.



NOTICE

The enclosure specified in the Technical Data chapter only applies if the screw plugs of the setpoint potentiometer and the X50 diagnostic interface are installed correctly.

A missing or incorrectly installed screw plug can cause damage to the MOVIMOT® inverter.

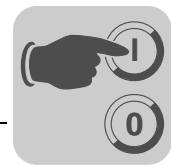

5. Set the 2nd speed at switch f2 (active when terminal f1/f2 = "1").



Switch f2											
Detent setting	0	1	2	3	4	5	6	7	8	9	10
Setpoint f2 [Hz]	5	7	10	15	20	25	35	50	60	70	100



INFORMATION

The first speed can be changed infinitely variable during operation using the setpoint potentiometer f1, which is accessible from the outside.

Speeds f1 and f2 can be set independently of each other.

6. Set the ramp time at the switch t1.

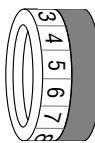

The ramp times are based on a setpoint step change of 1500 rpm (50 Hz).

Switch t1											
Detent setting	0	1	2	3	4	5	6	7	8	9	10
Ramp time t1 [s]	0.1	0.2	0.3	0.5	0.7	1	2	3	5	7	10

7. Place the MOVIMOT® inverter onto the terminal box and screw it on.

8. Switch on the DC 24 V and the supply system voltage.

6.5.1 Inverter behavior depending on terminal level

Inverter behavior	Power supply	24V	f1/f2	CW/stop	CCW/stop	Status LED
Inverter off	0	0	x	x	x	Off
Inverter off	1	0	x	x	x	Off
Stop, no supply system	0	1	x	x	x	Flashing yellow
Stop	1	1	x	0	0	Yellow
CW operation with f1	1	1	0	1	0	Green
CCW operation with f1	1	1	0	0	1	Green
CW operation with f2	1	1	1	1	0	Green
CCW operation with f2	1	1	1	0	1	Green
Stop	1	1	x	1	1	Yellow

Key

0 = No voltage

1 = Voltage

x = Any



6.6 Supplementary notes for installation close to the motor

6.6.1 Checking the connection type of the connected motor

Use the following figure to check that the selected connection type is identical for the MOVIMOT® and the connected motor.



337879179

Important: For brake motors: Do not install brake rectifiers inside the terminal box of the motor!

6.6.2 Motor protection and direction of rotation enable

The connected motor must be equipped with a TH.

- For control via RS-485, the TH must be wired as follows:

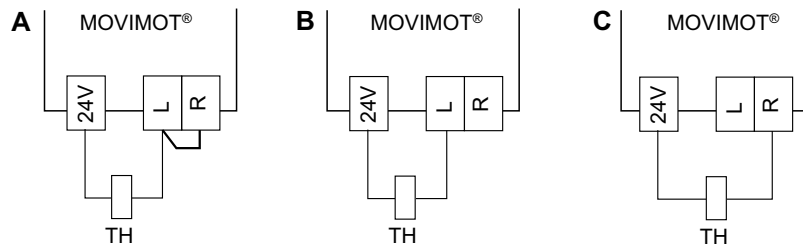

2036204171

- [A] Both directions of rotation are enabled
- [B] Only **CCW** operation is enabled
- [C] Only **CW** operation is enabled

- For control via binary signals, SEW-EURODRIVE recommends that you connect the TH in series with the "Ready signal" relay (see the following illustration).
 - The ready signal must be monitored by an external controller.
 - As soon as the ready signal is no longer applied, the drive must be switched off (terminals R \curvearrowright and L \curvearrowleft = "0").

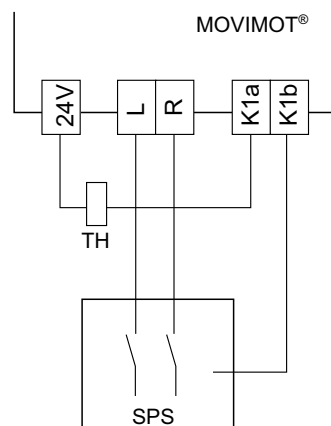

2036433291

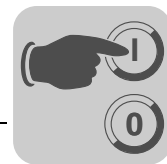

6.6.3 DIP switch

When the MOVIMOT® inverter is installed close to the motor, the DIP switch S1/5 must be changed from the factory setting to "ON":

S1 Meaning	1	2	3	4	5 Motor protection	6 Motor power rating	7 PWM Frequency	8 No-load damping
	RS-485 unit address							
	2 ⁰	2 ¹	2 ²	2 ³				
ON	1	1	1	1	Off	Motor one size smaller	Variable (16, 8, 4 kHz)	On
OFF	0	0	0	0	On	Adjusted	4 kHz	Off

6.6.4 Braking resistor

- For **motors without brake**, a braking resistor must be connected to MOVIMOT® (see figure to the right).
- For **brakemotors without BGM option**, no braking resistor may be connected to the MOVIMOT®.

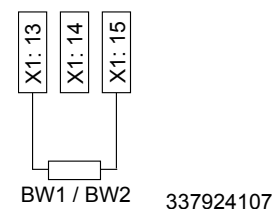

- For **brakemotors with BGM option** and external braking resistor, the external braking resistor and the brake must be connected as follows.

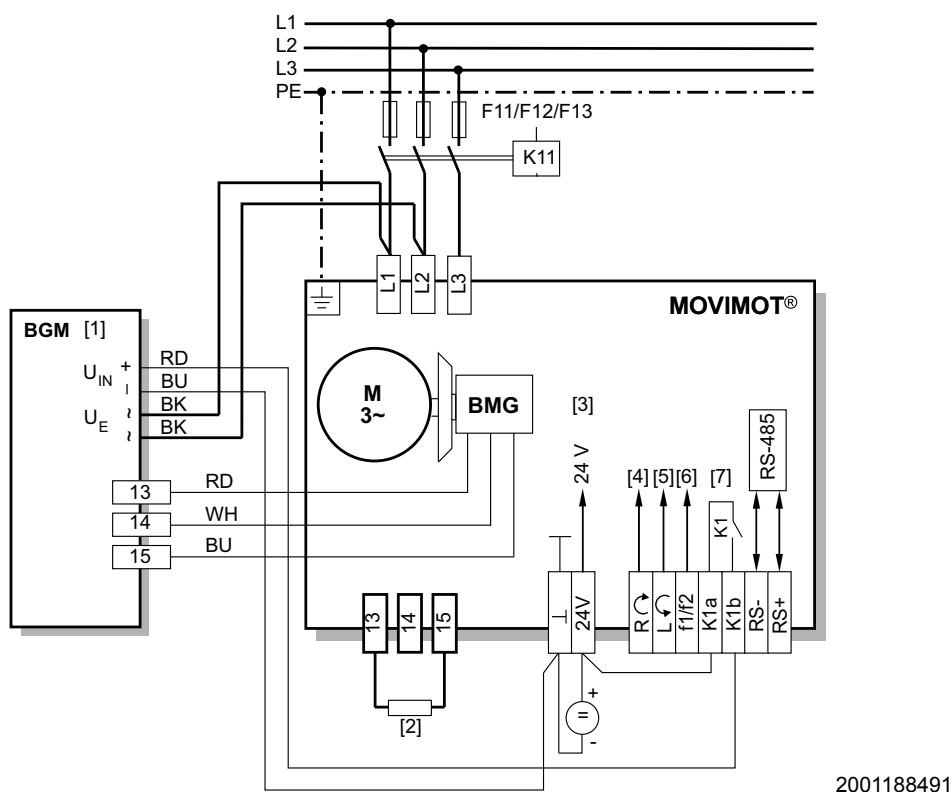

6.6.5 Mounting the MOVIMOT® inverter in the field distributor

Follow the instructions in the corresponding fieldbus manuals when mounting the MOVIMOT® inverter close to the motor in the field distributor.



7 Startup with RS-485 Interface/Fieldbus

7.1 Important notes on startup

	<p>⚠ DANGER</p> <p>Before removing / fitting the MOVIMOT[®] inverter, you must disconnect it from the supply system. Dangerous voltages may still be present for up to one minute after disconnection from the power supply.</p> <p>Severe or fatal injuries from electric shock.</p> <ul style="list-style-type: none"> • Disconnect the MOVIMOT[®] drive from the power supply using an appropriate external disconnecting device and secure it against unintentional reconnection to the voltage supply. • Then wait at least for 1 minute.
	<p>⚠ WARNING</p> <p>The surfaces of MOVIMOT[®] and external options, e.g. braking resistor (especially the heat sink), can become very hot during operation.</p> <p>Danger of burns.</p> <ul style="list-style-type: none"> • Do not touch the MOVIMOT[®] drive and external options until they have cooled down sufficiently.
	<p>INFORMATION</p> <ul style="list-style-type: none"> • Remove paint protection cap from the status LED before startup. • Remove paint protection film from the nameplates before startup. • Check that all protective covers are installed correctly. • Observe a minimum switch-off time of 2 seconds for the mains contactor K11.

7.2 Startup procedure

1. Check the connection of the MOVIMOT[®] inverter.
See chapter "Electrical Installation".

2. Set the correct RS-485 address on DIP switches S1/1 – S1/4.

In conjunction with SEW fieldbus interfaces (MF.. / MQ..) or with MOVIFIT[®], always set address "1".

Decimal address	0	1	2	3	4	5	6	7	8	9	10	11	12	13	14	15
S1/1	–	X	–	X	–	X	–	X	–	X	–	X	–	X	–	X
S1/2	–	–	X	X	–	–	X	X	–	–	X	X	–	–	X	X
S1/3	–	–	–	–	X	X	X	X	–	–	–	–	X	X	X	X
S1/4	–	–	–	–	–	–	–	–	X	X	X	X	X	X	X	X

X = ON
– = OFF

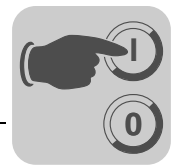

3. Set minimum frequency f_{min} with switch f2.



Switch f2											
Detent setting	0	1	2	3	4	5	6	7	8	9	10
Minimum frequency f_{min} [Hz]	2	5	7	10	12	15	20	25	30	35	40

4. If the ramp is not specified via fieldbus (operation with 2 PD), set the ramp time at switch t1.



The ramp times are based on a setpoint step change of 1500 rpm (50 Hz).

Switch t1											
Detent setting	0	1	2	3	4	5	6	7	8	9	10
Ramp time t1 [s]	0.1	0.2	0.3	0.5	0.7	1	2	3	5	7	10

5. Check to see if requested direction of rotation has been enabled.

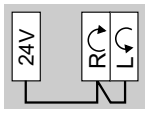
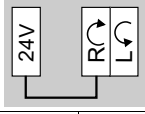
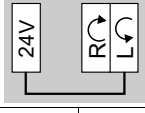
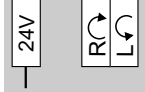
CW/stop	CCW/stop	Meaning
Activated	Activated	<ul style="list-style-type: none"> Both directions of rotation are enabled
		
Activated	Not activated	<ul style="list-style-type: none"> Only CW operation enabled Pre-selected setpoints for CCW rotation result in standstill of drive
		
Not activated	Activated	<ul style="list-style-type: none"> Only CCW operation enabled Pre-selected setpoints for CW rotation result in standstill of drive
		
Not activated	Not activated	<ul style="list-style-type: none"> Unit is inhibited or drive brought to a stop
		

6. Place the MOVIMOT® inverter onto the terminal box and screw it on.



7. Set the required maximum speed using setpoint potentiometer f1.

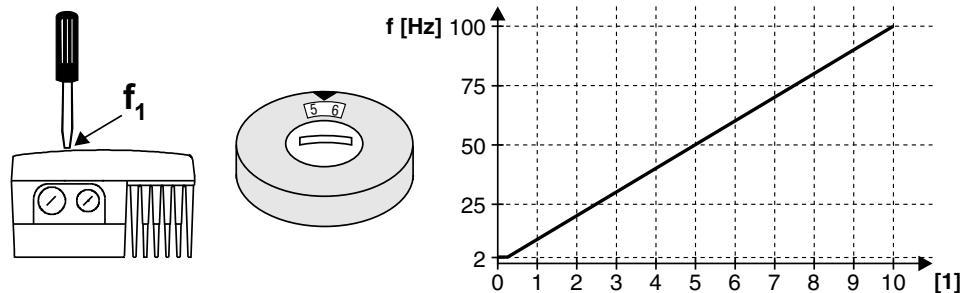

329413003

[1] Potentiometer setting

8. Make sure the screw plug of the setpoint potentiometer f1 has a seal and screw it in.



NOTICE

The enclosure specified in the Technical Data chapter only applies if the screw plugs of the setpoint potentiometer and the X50 diagnostic interface are installed correctly.

A missing or incorrectly installed screw plug can cause damage to the MOVIMOT® inverter.

9. Switch on the DC 24 V control voltage / supply system voltage.



INFORMATION

For information on the function in conjunction with RS-485 master, refer to the operating instructions.

For further information on the function in connection with fieldbus interfaces, refer to the relevant fieldbus manuals.

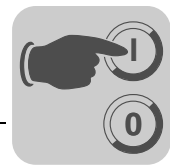

8 Operation

8.1 Operating display

The status LED is located on the top of the MOVIMOT® inverter (see following figure).

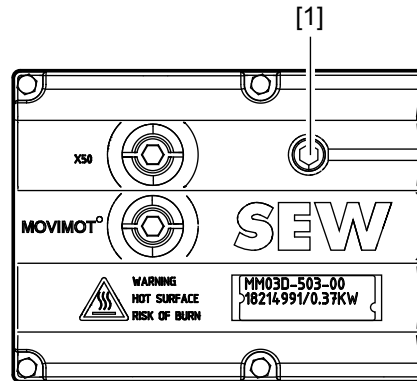

459759755

[1] MOVIMOT® status LED

8.1.1 Meaning of the status LED states

The three-color status LED indicates the operating and error states of the MOVIMOT® inverter.

LED color	LED status	Operating state	Description
–	Off	Not ready	No 24 V power supply
Yellow	Flashes steadily	Not ready	Self-test phase active or 24 V power supply present but supply voltage not OK
Yellow	Flashing evenly, fast	Ready	Brake release without drive enable active (only with S2/2 = "ON")
Yellow	Steady light	Ready, but unit inhibited	24 V power supply and supply voltage OK, but no enable signal If drive does not run when enable signal is present - check startup!
Green /yellow	Flashing with alternating colors	Ready, but timeout	Faulty communication with cyclical data exchange
Green	Steady light	Unit enabled	Motor in operation
Green	Flashing evenly, fast	Current limit active	Drive operating at current limit
Red	Steady light	Not ready	Check the 24 V supply. Make sure that there is a smoothed DC voltage with low ripple (residual ripple max. 13%) present

Status LED flash codes

Flashing steadily: LED 600 ms on, 600 ms off
 Flashing evenly, fast: LED 100 ms on, 300 ms off
 Flashing with alternating colors: LED 600 ms green, 600 ms yellow

For a description of error states, refer to section "Status and error display" (page 42).



9 Service

9.1 Status and error display

9.1.1 Status LED

The status LED is located on the top of the MOVIMOT® inverter.

Meaning of the status LED

The three-color status LED indicates the operating and error states of the MOVIMOT® inverter.

LED color	LED status	Error code	Description
–	Off	Not ready	No 24 V power supply
Yel-low	Flashes steadily	Not ready	Self-test phase active or 24 V power supply present but supply voltage not OK
Yel-low	Flashing evenly, fast	Ready	Releasing the brake active without drive enable (only with S2/2 = "ON")
Yel-low	Steady light	Ready, but unit inhibited	24 V power supply and supply voltage OK, but no enable signal If drive does not run when enable signal is present - check startup!
Green /yel-low	Flashing with alternating colors	Ready, but timeout	Faulty communication with cyclical data exchange
Green	Steady light	Unit enabled	Motor in operation
Green	Flashing evenly, fast	Current limit active	Drive operating at current limit
Red	Steady light	Not ready	Check the 24 V supply. Make sure that there is a smoothed DC voltage with low ripple (residual ripple max. 13%) present
Red	2x flashing, break	Error 07	DC link voltage too high
Red	Flashing slowly	Error 08	Speed monitoring error (only with S2/4 = "ON") or additional function 13 is active
		Error 90	Incorrect motor/inverter assignment
		Errors 17-24, 37	CPU error
		Error 25, 94	EEPROM error
Red	3x flashing, break	Error 01	Overcurrent in output stage
		Error 11	Overtemperature in output stage
Red	4x flashing, break	Error 84	Overload in motor
Red	5x flashing, break	Error 89	Overtemperature in brake Assignment of motor to frequency inverter incorrect
Red	6x flashing, break	Error 06	Mains phase failure
		Error 81	Start condition ¹⁾
		Error 82	Output phases interrupted ¹⁾

1) Only in hoist applications

The error codes are described on the next page.

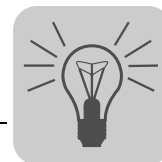

9.1.2 Error list

Error	Cause/solution
Communication timeout (motor stops, without error code)	<ul style="list-style-type: none"> • Missing connection \perp RS+, RS- between MOVIMOT[®] and RS-485 master. Check and establish connection, especially earth. • EMC influence. Check shielding of data lines and improve, if necessary. • Incorrect type (cyclical) in acyclical data transfer, protocol time between the individual message is longer than 1 s (timeout interval). <p>Check the number of MOVIMOT[®] units connected to the master (a maximum of 8 MOVIMOT[®] units can be connected as slaves for cyclic communication).</p> <p>Reduce message cycle or select message type "acyclic".</p>
DC link voltage too low, supply system off was detected (motor stops, without error code)	<p>Check supply system leads, supply voltage and 24 V electronics supply voltage for interruption. Check the value of the 24 V electronics supply voltage (permitted voltage range 24V \pm 25 %, EN 61131-2 residual ripple max. 13 %)</p> <p>In case of cyclical communication, the motor restarts automatically as soon as the voltage reaches normal values.</p>
Error code 01 Overcurrent in output stage	<p>Short circuit on inverter output.</p> <p>Check the connection between the inverter output and the motor as well as the motor winding for short circuits.</p> <p>Reset the fault by switching off the DC 24 V supply voltage or resetting the error.</p>
Error code 06 Phase failure (The error can only be detected when the drive is at load)	<p>Check the supply system cable for phase failure.</p> <p>Reset the fault by switching off the DC 24 V supply voltage or resetting the error.</p>
Error code 07 DC link voltage too high	<ul style="list-style-type: none"> • Ramp time too short → Increase ramp time. • Faulty connection between brake coil/braking resistor → Check the connection between braking resistor and brake coil. Correct, if necessary. • Incorrect internal resistance of brake coil/braking resistor → Check internal resistance of brake coil/braking resistor (see "Technical Data" chapter in the operating instructions). • Thermal overload in braking resistor → Wrong size of braking resistor selected. • Invalid voltage range of the supply input voltage → Check supply input voltage for valid voltage range <p>Reset the error by switching off the DC 24 V supply voltage or resetting the error.</p>
Error code 08 Speed monitoring	<p>Speed monitoring has triggered, load on the drive is too high</p> <p>Reduce the load on the drive</p> <p>Reset the error by switching off the DC 24 V supply voltage or resetting the error.</p>
Error code 11 Thermal overload of the output stage or internal unit error	<ul style="list-style-type: none"> • Clean the heat sink • Lower ambient temperature • Prevent heat build-up • Reduce the load on the drive <p>Reset the error by switching off the DC 24 V supply voltage or resetting the error.</p>
Error codes 17 to 24, 37 CPU error	<p>Reset the error by switching off the 24 V power supply or via error reset.</p> <p>Consult the SEW Service if the error reoccurs.</p>
Error code 25 EEPROM error	<p>Error while accessing EEPROM</p> <p>Reset the error by switching off the 24 V power supply or via error reset.</p> <p>Consult the SEW Service if the error reoccurs.</p>



Error	Cause/solution
Error code 43 communication timeout	<p>Communication timeout during cyclical communication via RS-485 If this error occurs, the drive is decelerated and stopped along the set ramp.</p> <ul style="list-style-type: none"> • Check/establish communication link between RS-485 master and MOVIMOT®. • Check the number of slaves connected to the RS-485 master. If the timeout interval of the MOVIMOT® inverter is set to 1 s, you can connect a maximum of 8 MOVIMOT® inverters (slaves) to the RS-485 master for cyclical communication. <p>Note: The drive is enabled again after communication has been re-established.</p>
Error code 81 Start condition error	<p>The motor could not be supplied with the correct amount of current during the pre-magnetizing time.</p> <ul style="list-style-type: none"> • Rated motor power too small in relation to rated inverter power • Motor cable cross section too small <p>Check connection between MOVIMOT® inverter and motor.</p>
Error code 82 Output open error	<ul style="list-style-type: none"> • 2 or all output phases interrupted • Rated motor power too small in relation to rated inverter power <p>Check connection between MOVIMOT® inverter and motor.</p>
Error code 84 Thermal overload of motor	<ul style="list-style-type: none"> • When the MOVIMOT® inverter is installed close to the motor, set DIP switch S1/5 to "ON". • For combinations of "MOVIMOT® and motor with one lower power rating", check the setting of DIP switch S1/6. • Lower ambient temperature • Prevent heat build-up • Reduce the load on the motor • Increase the speed • Check the combination of the drive and MOVIMOT® inverter if the fault is signaled shortly after the first enable. • The temperature monitoring in the motor (TH winding thermostat) has tripped when using MOVIMOT® with the selected extra function 5 → Reduce load on the motor. <p>Reset the error by switching off the DC 24 V supply voltage or resetting the error.</p>
Error code 89 Thermal overload of brake coil or brake coil defective, brake coil connected incorrectly	<ul style="list-style-type: none"> • Increase the set ramp time • Brake inspection (see "DR/DV/DT/DTE/DVE Series AC Motors" operating instructions") • Check brake coil connection • Contact SEW Service • Check the combination of the drive (brake coil) and MOVIMOT® inverter if the fault is signaled shortly after the first enable. • For combinations of "MOVIMOT® and motor with one lower power rating", check the setting of DIP switch S1/6. <p>Reset the error by switching off the DC 24 V supply voltage or resetting the error.</p>
Error code 94 EEPROM checksum error	<ul style="list-style-type: none"> • Defective EEPROM <p>Contact SEW Service.</p>



9.2 Replacing units

	<p>⚠ DANGER</p>
	<p>When working on the unit, dangerous voltage levels may still be present up to one minute after the power supply is disconnected.</p> <p>Severe or fatal injuries from electric shock.</p> <ul style="list-style-type: none"> • Disconnect the MOVIMOT[®] drive from the supply system and secure it against unintentional reconnection to the voltage supply. • Then wait at least for 1 minute.

1. Remove the screws and take off the MOVIMOT[®] inverter from the terminal box.
2. Compare the data on the nameplate of the previous MOVIMOT[®] inverter with the data on the nameplate of the new MOVIMOT[®] inverter.

	<p>NOTICE</p>
	<p>The previous MOVIMOT[®] inverter can only be replaced by a MOVIMOT[®] inverter with the same power rating and the same input voltage.</p>

3. Set all the controls (DIP switch S1, DIP switch S2, setpoint potentiometer f1, switch f2, switch t1) on the new MOVIMOT[®] inverter in the same way as the controls of the previous MOVIMOT[®] inverter.
4. Make sure that no Drive-ID module for DR motor types is plugged into the MOVIMOT[®] inverter

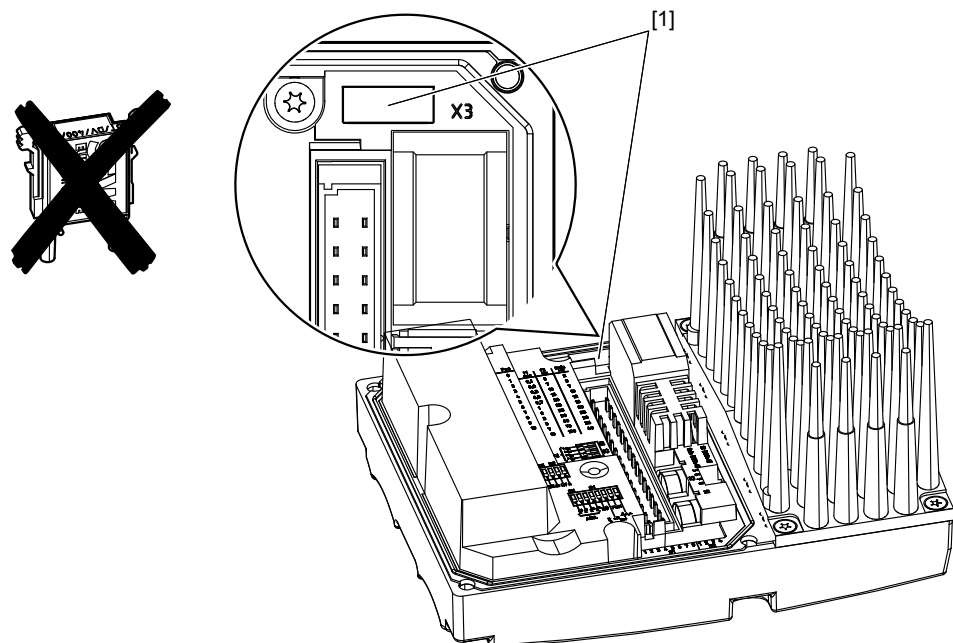

2037035019

[1] Slot for Drive-ID module

5. Place the new MOVIMOT[®] inverter onto the terminal box and screw it on.
6. Supply voltage to the MOVIMOT[®] inverter.
Check whether the new MOVIMOT[®] inverter is functioning properly.

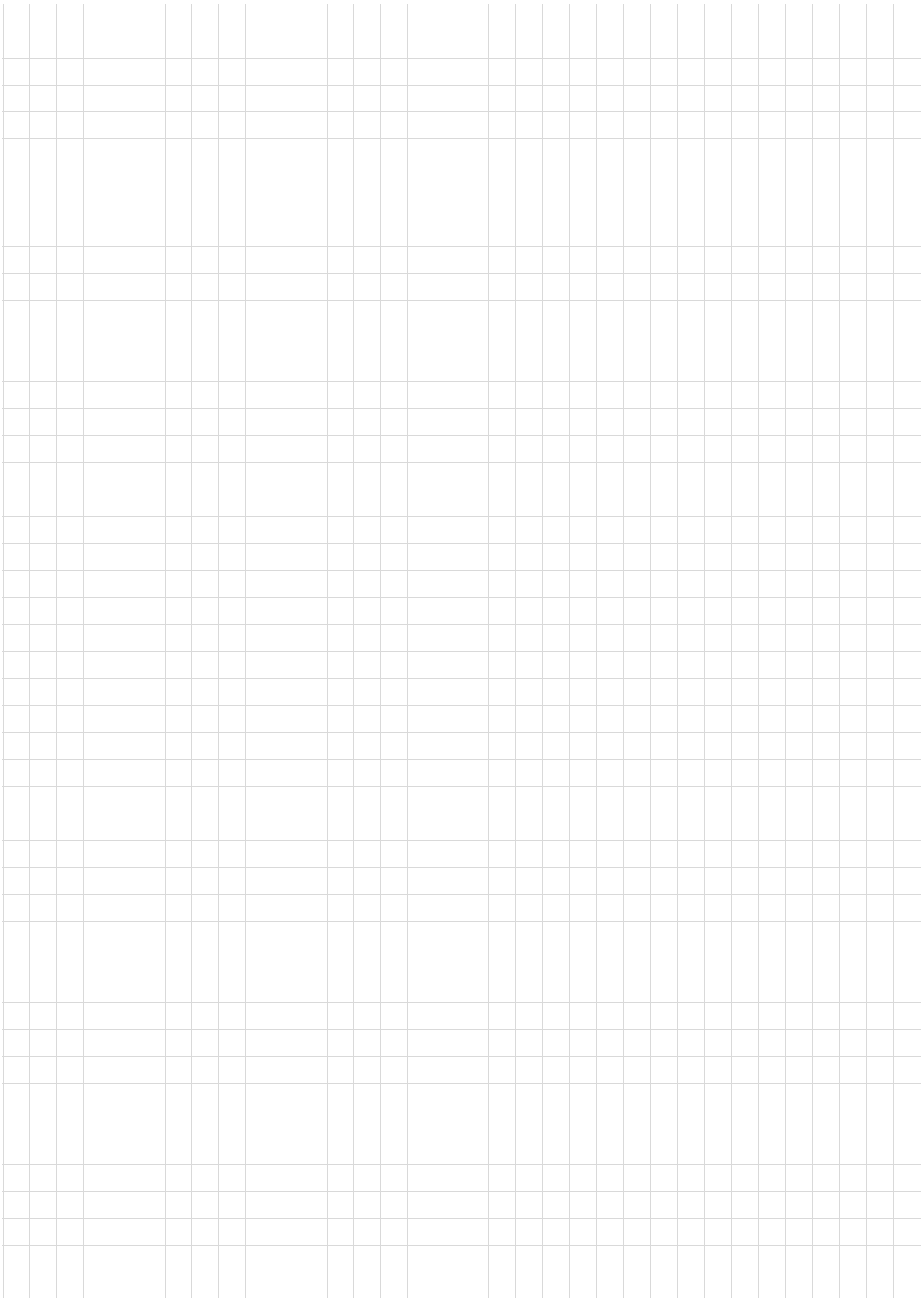

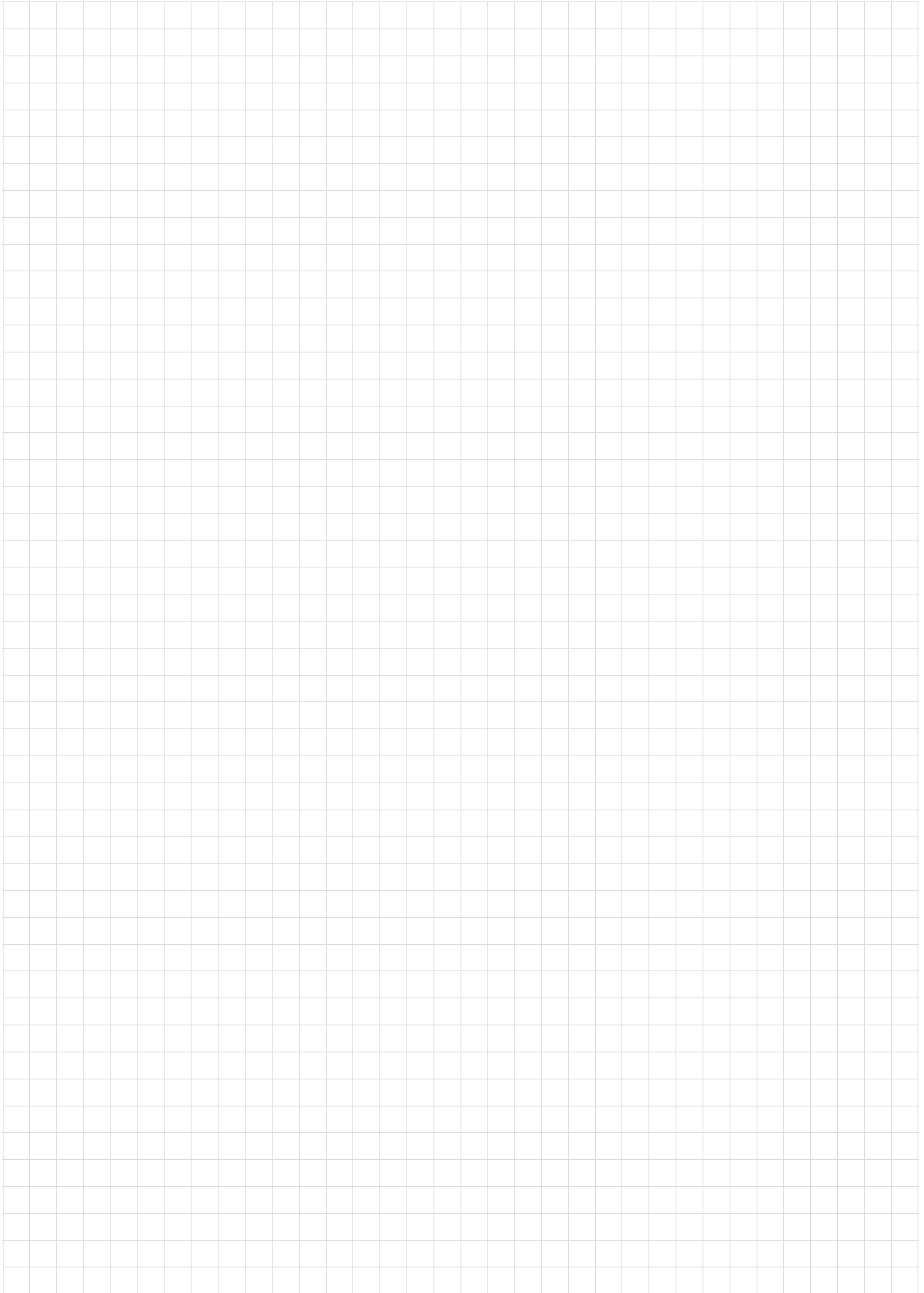

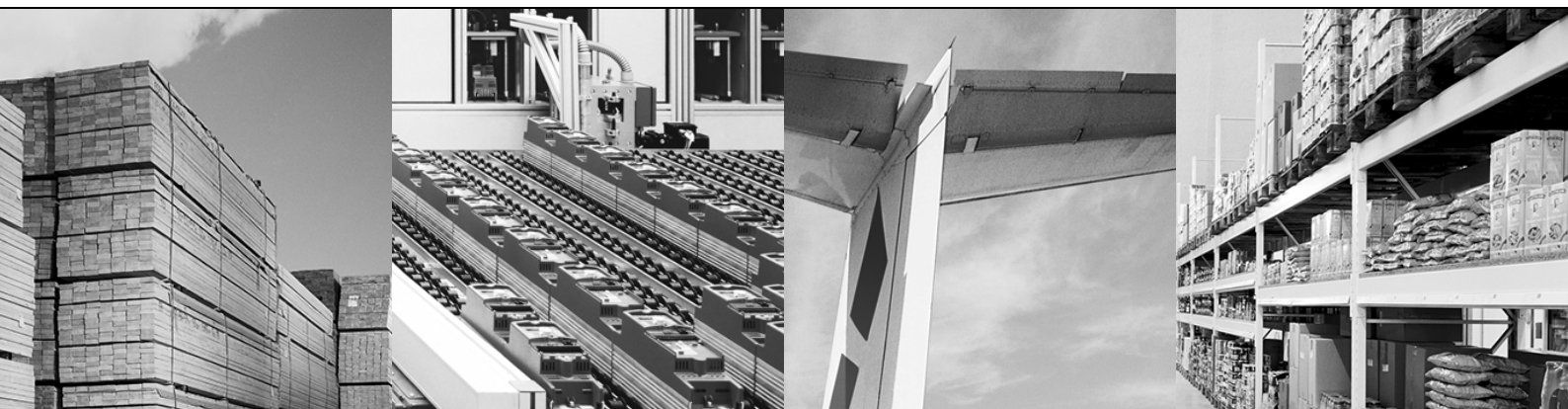
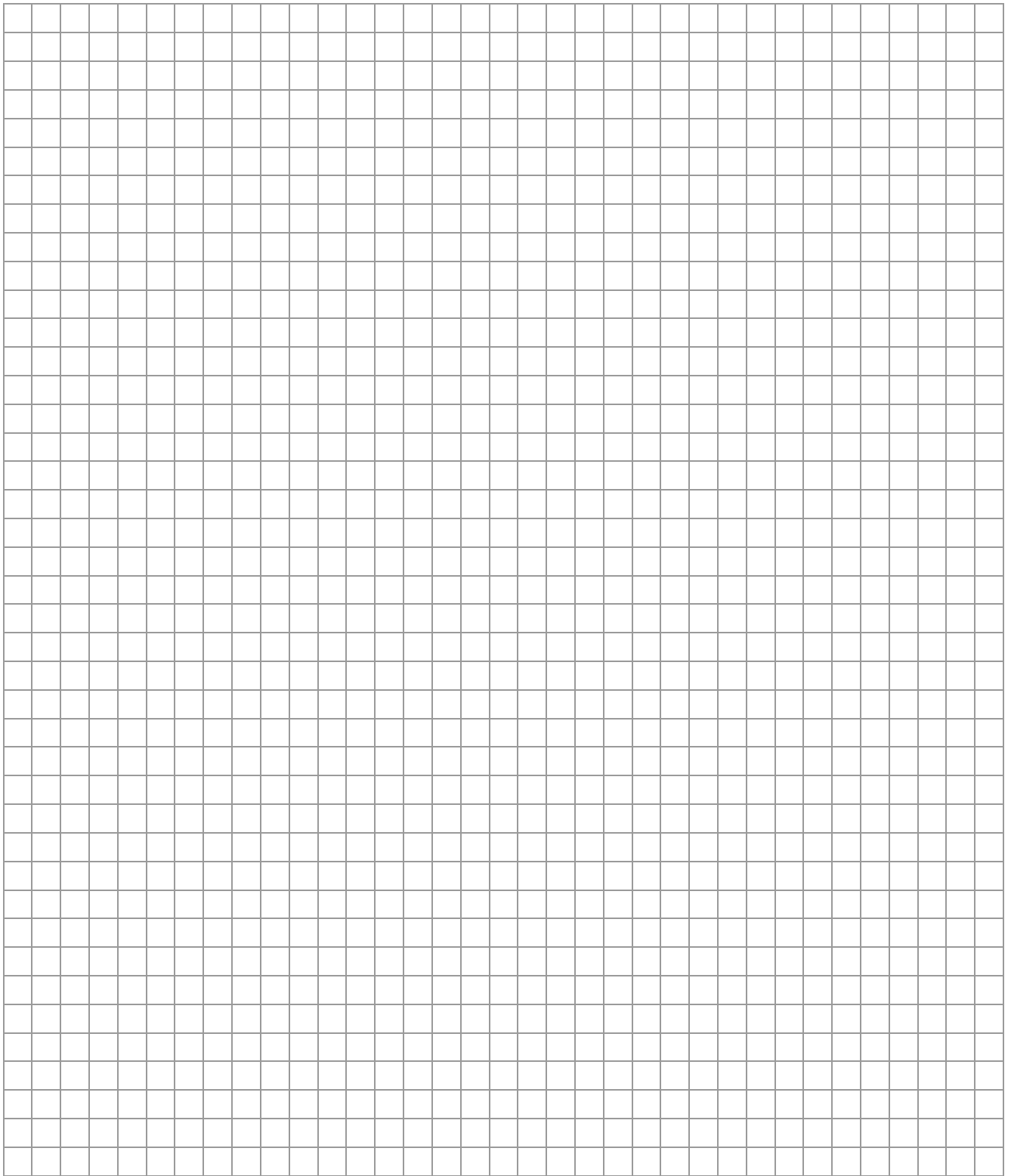



SEW-EURODRIVE
Driving the world

SEW
EURODRIVE

SEW-EURODRIVE GmbH & Co KG
P.O. Box 3023
D-76642 Bruchsal/Germany
Phone +49 7251 75-0
Fax +49 7251 75-1970
sew@sew-eurodrive.com

→ www.sew-eurodrive.com